



2022
Product Catalog

SHELVING
CARTS
WALL SHELVING
CABINETS & RACKS
WARE HANDLING
WORK STATIONS
FOOD CARRIERS



VIEW CURRENT
CATALOG WITH LATEST
UPDATES

FOODSERVICE

metro.com





We put space to work.

What's new?

How we make you more organized & efficient.

We offer a unique product portfolio and an expertise that is unmatched. Our understanding of you, the customer, and our ability to match a product or solution to solve a problem is proven to have a positive effect on businesses in any industry. Our trained professionals get processes on-track to store more, do more, and save more.



NEW C5 9 & 8 Series
Simple-touch controller
pg.180



NEW Metroseal Gray
Super Erecta shelving with
gray rust resistant epoxy
pg.48



NEW Super Erecta® Hot
Heated Shelving
pg.170



NEW Builder Design Tools
Customize in 3D
metro.com/design-tools



Conquer the day.

Our obsession to understand the customer is what drives us. The better we know how you work and what you need gives us the right tools to innovate space better. Since 1929, we've been observing customers' challenges to find ideal solutions within virtually every application.

Delivering value based products & solutions.

We continue to innovate the highest quality products in our space, utilizing unique materials and advanced production processes to deliver relevant, leading edge solutions. Born from the creation of the industry standard for wire shelving, our product breadth has evolved into a vast array of product categories including plastic & wire shelving, medical carts, storage cabinets, workstations, heated cabinets, high-density shelving, wall storage systems, stainless fabricated products and more.

We differentiate our products by the features that we build in. Be it adjustability, corrosion resistance, energy efficiency, modularity, maneuverability, ergonomics, or durability, our products provide unrivaled performance and value. These features enable us to configure, tailor, accessorize and customize these products into application-specific solutions that ensure professionals have the right tool for the job.

- www.facebook.com/MetroFoodserviceSolutions
- www.linkedin.com/company/intermetroindustriescorp
- www.instagram.com/metrofoodservice
- www.twitter.com/MetroFS
- www.metro.com/YouTube

Corporate Headquarters
651 North Washington Street
Wilkes-Barre, PA 18705
Phone: +1 570 825 2741
Fax: +1 570 825 2852

U.S. & Canada Customer Service
Phone: 1.800.992.1776
Fax (PA): +1 800 638 9263
Fax: (CA): +1 800 638. 3292

**International Sales/
Customer Service Offices**
Middle East/Africa/India
Dubai-United Arab Emirates
Phone: +971 4 811 8286
Fax: +971 4 886 5465

Asia/Pacific
Singapore
Phone: +65 6829 5382

Latin America
Mexico
Phone: +52 33 362 778 30

Europe
The Netherlands
Phone: +31 76 587 7550
Fax: +31 76 581 1313

Contents

Polymer Shelving Solutions 10-33

| | |
|--|-------|
| MetroMax i Shelves and Posts..... | 12-13 |
| MetroMax 4 Shelves and Posts..... | 14-15 |
| MetroMax Q Shelves and Posts..... | 16-17 |
| MetroMax Casters..... | 18-19 |
| Mobile Shelving, Carts, and Utility Carts..... | 20-21 |
| MetroMax Supply and Speciality Carts..... | 22-23 |
| MetroMax Platform Accessories..... | 24-29 |
| MetroMax Drying Racks..... | 30-33 |

Wire and Solid Shelving Solutions 34-93

| | |
|--|-------|
| Wire/Polymer Hybrid Shelving..... | 36-39 |
| Easy-Adjust Shelving and Carts..... | 40-45 |
| Wire Shelving, Carts, and Trucks..... | 46-56 |
| Casters for Wire Shelving..... | 58-59 |
| Dollies & Plate Casters..... | 60-62 |
| Accessories for Wire Shelving..... | 63-73 |
| Solid Shelving and Accessories..... | 74-76 |
| Light-Duty Wire Shelving and Accessories..... | 77 |
| Heavy-Duty Solid Shelving and Accessories..... | 78-79 |
| qwikSLOT Adjustable Shelving..... | 80-83 |
| Basket Shelving and Accessories..... | 84-89 |
| Storage Bins and Totes..... | 90-93 |

Security, Track, and Seismic Shelving..... 94-117

| | |
|-----------------------------------|---------|
| Security Shelving..... | 96-99 |
| High-Density Track Shelving..... | 100-110 |
| Vertical Extra-High Shelving..... | 111 |
| Seismic Shelving..... | 112-117 |

Wall Shelving 118-130

| | |
|---------------------------------------|---------|
| SmartWall Grid and Wall Shelving..... | 120-127 |
| Wall Mounted Shelving..... | 128-130 |

Workstations and Worktables..... 132-147

| | |
|---|---------|
| Smartlever Workstations..... | 134-139 |
| Stainless Steel Worktables and Accessories..... | 140-145 |

Utility Carts and Dunnage 146-155

| | |
|---------------------------------|---------|
| Polymer Utility Carts..... | 148-151 |
| Wire & Solid Utility Carts..... | 152-153 |
| Dunnage Racks and Shelves..... | 154-155 |

Prep Tables & Application Based Units..... 156-167

| | |
|---|---------|
| PrepMate Prep Stations..... | 158-159 |
| SmartStation Application Based Units..... | 160-167 |

Food Warming & Insulated Carriers 168-177

| | |
|---|---------|
| Super Erecta Hot Heated Shelving..... | 170-171 |
| Metro2Go Hot Stations..... | 172-173 |
| Mightylite Front Load Pan Carriers..... | 174-175 |
| Mightylite Top Load Pan Carriers..... | 176 |
| Mightylite Accessories..... | 177 |

Thermal Cabinets & Racks 178-233

| | |
|--|---------|
| C5 Cabinet Line & Accessories..... | 180-211 |
| Heavy-Duty Heated Transport Cabinets..... | 212-217 |
| Heavy-Duty Mobile Refrigerators..... | 218-221 |
| Heated Banquet Cabinets & Accessories..... | 222-228 |
| Holding/Delivery/Storage Cabinets..... | 229 |
| Mobile Bun and Tray Racks..... | 230-233 |

Grocery, Retail, Speciality & Ware Handling 234-258

| | |
|--|---------|
| Grocery Solutions..... | 236-247 |
| Retail Solutions..... | 248-251 |
| Beer and Wine Storage & Accessories..... | 252-253 |
| Mini Bar Restocking Cart..... | 254 |
| Linen Trucks & Carts..... | 255 |
| "Poker Chip" Dish Dollies..... | 256-257 |
| Side-Load Dish and Tray Carts..... | 258 |

Terms and Conditions 259-261

Index Inside Back Cover



Select the right shelving for the job.

Innumerable Options. Imaginative Solutions.



LIFETIME



MetroMax® 4
All-Plastic, 100% Rust-Proof,
Removable Shelf Mats



Sectioned Solid Mats Available.



| Wet Environment | Cleanability | Abrasion Resistance | Accessorization | Shelf Capacity | Relative Price | Corrosion Warranty |
|-----------------|--------------|---------------------|-----------------|---------------------------|----------------|--------------------|
| ★★★★★ | ★★★★★ | ★★★★★ | ★★★ | 800lbs. (363kg) | \$\$\$ | Lifetime |

HEAVY DUTY



MetroMax® i
Heavy Duty, All-Plastic with Stainless
Steel Corners, 100% Rust-Proof,
Removable Shelf Mats



One-Piece Solid Mats Available.



| Wet Environment | Cleanability | Abrasion Resistance | Accessorization | Shelf Capacity | Relative Price | Corrosion Warranty |
|-----------------|--------------|---------------------|-----------------|----------------------------|-----------------|--------------------|
| ★★★★★ | ★★★★★ | ★★★★★ | ★★★ | 1000lbs. (454kg) | \$\$\$\$ | Lifetime |

QUICK ADJUST



MetroMax® Q
All-Plastic Removable Mats with
Epoxy Coated Wire Frames and Quick
Adjustment Feature



*Commonly used with All-Polymer posts.
Epoxy Coated Steel Posts also available.*



| Wet Environment | Cleanability | Abrasion Resistance | Accessorization | Shelf Capacity | Relative Price | Corrosion Warranty |
|-----------------|--------------|---------------------|-----------------|---------------------------|----------------|--------------------|
| ★★★★★ | ★★★★★ | ★★★★★ | ★★★ | 800lbs. (363kg) | \$\$\$ | 20 Years |

EASY CLEAN



Super Erecta Pro®
All-Plastic Removable Mats with
Epoxy Coated Wire Frames





| Wet Environment | Cleanability | Abrasion Resistance | Accessorization | Shelf Capacity | Relative Price | Corrosion Warranty |
|-----------------|--------------|---------------------|-----------------|---------------------------|----------------|--------------------|
| ★★★ | ★★★★★ | ★★★★★ | ★★★★★ | 800lbs. (363kg) | \$\$ | 15 Years |

ALL-PURPOSE



Super Erecta®
Wire Shelving

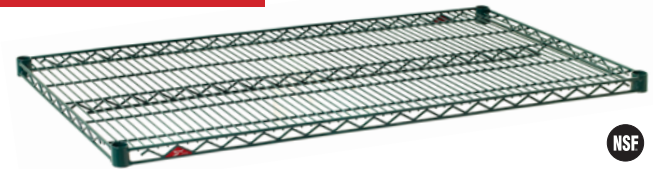

NSF



Available Finishes

| | | | | | | | | |
|--------|-------|-----------------|----------------|-----------------|-------|-------|--------------|------------------|
| Chrome | Brite | Metroseal Green | Metroseal Gray | Stainless Steel | Black | White | Smoked Glass | Copper Hammetone |
|--------|-------|-----------------|----------------|-----------------|-------|-------|--------------|------------------|

Wet Environment | **Cleanability** | **Abrasion Resistance** | **Accessorization** | **Shelf Capacity** | **Relative Price** | **Corrosion Warranty**

| | | | | | | |
|--------------------------|-------------------------|--------------------------|-------|---------------------------|-----------------------------|------------------------------|
| Metroseal ★★★ | Metroseal ★★★★ | Metroseal ★★★★ | | 800lbs. (363kg) | Metroseal \$ | Metroseal 12 Years |
| Stainless Steel ★★★★★ | Stainless Steel ★★★★ | Stainless Steel ★★★★★ | ★★★★★ | | Stainless Steel \$\$\$\$ | |
| Other ● | Other ★★★ | Other ★★★★★ | | | Other \$ | |

Available Finishes

| | | | |
|-------------|-----------------|--------------------------------------|------------|
| Galvanized* | Stainless Steel | Autoclave Cart Wash Stainless Steel* | NSF |
|-------------|-----------------|--------------------------------------|------------|

*Louvered Style is not available in Galvanized or Autoclave

Wet Environment | **Cleanability** | **Abrasion Resistance** | **Accessorization** | **Shelf Capacity** | **Relative Price**

| | | | | | |
|--------------------------|-------------------------|-------------------|-----|---------------------------|-----------------------------|
| Stainless Steel ★★★★★ | Stainless Steel ★★★★ | Galvanized ★★★ | ★★★ | 800lbs. (363kg) | Stainless Steel \$\$\$\$ |
| Galvanized ★★★ | Galvanized ★★★ | | | | Galvanized \$\$ |

Solid Shelving with Built-in Spill Containment

EASY ADJUST



**Super Adjustable
Super Erecta®**
Wire Shelving
with Quick Adjustment Feature



NSF



Available Finishes

| | | |
|--------|-----------------|-----------------|
| Chrome | Metroseal Green | Stainless Steel |
|--------|-----------------|-----------------|

Wet Environment | **Cleanability** | **Abrasion Resistance** | **Accessorization** | **Shelf Capacity** | **Relative Price** | **Corrosion Warranty**

| | | | | | | |
|--------------------------|-------------------------|--------------------------|-------|---------------------------|-----------------------------|------------------------------|
| Metroseal ★★★ | Metroseal ★★★★ | Metroseal ★★★★ | | 800lbs. (363kg) | Metroseal \$ | Metroseal 12 Years |
| Stainless Steel ★★★★★ | Stainless Steel ★★★★ | Stainless Steel ★★★★★ | ★★★★★ | | Stainless Steel \$\$\$\$ | |
| Chrome ● | Chrome ★ | Chrome ★★★★★ | | | Chrome \$ | |

HEATED



Super Erecta® Hot
Heated Shelving
with Built-in Temperature Control



Enclosure Kits Available



| Flexibility | Cleanability | Adjustability | Abrasion Resistance | Max Temp. | Relative Price |
|-------------|--------------|---------------|---------------------|---------------------|-----------------|
| ★★★★★ | ★★★★★ | ★★★★★ | ★★★★★ | 200°F (93°C) | \$\$\$\$ |

Recommended shelving for cooler & freezer applications.

Options for any application or budget.

Most used for:

- Coolers
- Freezers
- Standard Loads
- Mobile Applications
- Dish Areas
- Drying Racks
- Wet Areas
- Wall Shelving
- Dry Storage
- Track Shelving
- Security Shelving

Styles and finishes are available in stationary, mobile, or movable aisle track systems.



Super Erecta® Pro



Plastic Removable Mats with Epoxy Coated Wire Frames

- ☺ **15-YEAR** CORROSION WARRANTY
- ☺ **EASY-TO-CLEAN,** REMOVABLE MATS
- ☺ **HOLDS UP TO 800 LBS** (454kg) PER SHELF
2000 LBS (907kg) PER UNIT
1000 LBS (454kg) PER MOBILE UNIT

- DEPTHS: 14,18,21,24" [355,457,530,610mm]
- LENGTHS: 24,30,36,42,48,54,60,72" [610,760,914,1060,1219,1372,1524,1829mm]

MetroMax® Q



Plastic Removable Mats with Epoxy Coated Wire Frames and Quick Adjustment Feature

- ☑ **20-YEAR** CORROSION WARRANTY
- ☑ **EASY-TO-CLEAN,** REMOVABLE MATS
- ☑ **HOLDS UP TO 800 LBS** (454kg) PER SHELF
2000 LBS (907kg) PER UNIT
1000 LBS (454kg) PER MOBILE UNIT

- DEPTHS: 14,18,21,24" [355,457,530,610mm]
- LENGTHS: 24,30,36,42,48,54,60,72" [610,760,914,1060,1219,1372,1524,1829mm]

MetroMax® 4



All-Plastic, 100% Rust Proof Removable Mats

- 👍 **LIFETIME** CORROSION WARRANTY
- 👍 **EASY-TO-CLEAN,** REMOVABLE MATS
- 👍 **HOLDS UP TO 800 LBS** (363kg) PER SHELF
2000 LBS (907kg) PER UNIT
750 LBS (340kg) PER MOBILE UNIT
- 👍 **TEAR RESISTANT** SURFACES

- DEPTHS: 18,21,24 [457,530,610mm]
- LENGTHS: 24,30,36,42,48,54,60" [610,760,914,1060,1219,1372,1524mm]



Take confidence to the max.

MetroMax[®] All-Polymer Shelving System



PLAY VIDEO

Safely Hold up to
2000 lbs.
per unit.



MetroMax Shelving

RUST PROOF POLYMER & HYBRID POLYMER/WIRE SHELVING

| | |
|--|--------------|
| Polymer Shelving Solutions | 10-33 |
| MetroMax i Shelves & Posts..... | 12-13 |
| MetroMax 4 Shelves & Posts..... | 14-15 |
| MetroMax Q Shelves & Posts..... | 16-17 |
| MetroMax Casters..... | 18-19 |
| Mobile Shelving, Carts, & Utility Carts..... | 20-21 |
| MetroMax Supply & Speciality Carts..... | 22-23 |
| MetroMax Platform Accessories..... | 24-29 |
| MetroMax Drying Racks..... | 30-33 |



CORROSION LIFETIME WARRANTY

MetroMax® i Polymer Shelving — {9.20}

Shelves

- Includes shelf with removable mats and one bag of wedges.

| Nominal Width/Length (in.) (mm) | Cat. No. Shelf w/ Grid Mats | Cat. No. Shelf w/ Solid Mats | Cat. No. High-Impact Dunnage Shelves |
|---------------------------------|-----------------------------|------------------------------|--------------------------------------|
| 18x24 | 457x610 | MX1824G | MX1824F |
| 18x30 | 457x760 | MX1830G | MX1830F |
| 18x36 | 457x914 | MX1836G | MX1836F |
| 18x42 | 457x1060 | MX1842G | MX1842F |
| 18x48 | 457x1219 | MX1848G | MX1848F |
| 18x54 | 457x1372 | MX1854G | MX1854F |
| 18x60 | 457x1524 | MX1860G | MX1860F |
| 18x72 | 457x1829 | MX1872G | MX1872F |
| 24x24 | 610x610 | MX2424G | MX2424F |
| 24x30 | 610x760 | MX2430G | MX2430F |
| 24x36 | 610x914 | MX2436G | MX2436F |
| 24x42 | 610x1060 | MX2442G | MX2442F |
| 24x48 | 610x1219 | MX2448G | MX2448F |
| 24x54 | 610x1372 | MX2454G | MX2454F |
| 24x60 | 610x1524 | MX2460G | MX2460F |
| 24x72 | 610x1829 | MX2472G | MX2472F |

Actual Dimensions: Width: Add .25" (6mm) to nominal size. Length: Subtract .25" (6mm) from nominal size.

Standard Shelves: Maximum weight capacity evenly distributed: Up to and including 48" (1220mm) long shelf, 1000 lbs. (454kg); 54" (1372mm) and longer, 750 lbs. (340kg).

High-Impact Dunnage Shelves: maximum weight capacity evenly distributed: Up to and including 48" (1220mm) long shelf, 1200 lbs. (544kg); 900 lbs. (408kg) for 60" (1524mm).



Standard shelf with solid mat



Standard shelf with grid mat



Heavy-duty grid shelf

The easiest way to customize MetroMax® in 3D.

Stationary



Mobile



Stationary posts include a leveling foot that can be adjusted 1" (25mm).

Polymer Posts

- Corrosion proof with built-in Microban antimicrobial product protection.

| Nominal Height (in.) (mm) | Approx. Pkd. Wt. (lbs.) (kg) | Cat. No. Stationary Post with Leveling Foot | Cat. No. Mobile Post for Stem Caster | | |
|---------------------------|------------------------------|---|--------------------------------------|-------|--------|
| 9 | 228 | 0.3 | 0.15 | — | MX9UP |
| 13 | 330 | 0.5 | 0.2 | MX13P | MX13UP |
| 27 | 685 | 0.9 | 0.4 | MX27P | MX27UP |
| 33 | 838 | 1.0 | 0.5 | MX33P | MX33UP |
| 54 | 1372 | 1.6 | 0.7 | MX54P | MX54UP |
| 63 | 1600 | 1.8 | 0.8 | MX63P | MX63UP |
| 70 | 1778 | 2.0 | 0.9 | — | MX70UP |
| 74 | 1880 | 2.2 | 1.0 | MX74P | MX74UP |
| 86 | 2184 | 3.0 | 1.4 | MX86P | MX86UP |

Special height cut posts are available. Dolly applications require stationary posts. Consult your Metro representative.

NOTE: For maximum rigidity on heavily loaded carts, steel posts may be used. See page 16 for models.



MetroMax® i Replacement Wedges

Bag of (4)
Cat. No. MX9985
MetroMax® i Wedges are not compatible with original MetroMax shelves and posts.



Post Clamp

Adds stability by joining posts of two separate units together. Each unit is supported by four posts and buttressed by the adjacent unit.
Cat. No. 9994X



Foot Plate

Use to add stability to the shelving unit or to bolt units to the floor.
Cat. No. Zinc 9993Z
Cat. No. Stainless Steel 9993S

Note: MetroMax® i shelves, posts, and wedges are not compatible with original MetroMax shelves and posts.



MetroMax® i Shelving Starter and Add-On Units — {9.10}

- Starter Units consist of four polymer posts and indicated number of MetroMax i shelves.
- Add-On Units consist of two polymer posts, indicated number of shelves, and two "S" Hooks per shelf, for attaching add-on unit to starter unit in an end-to-end configuration. To attach shelves at right angles, Intermediate "S" Hook Kits must be ordered separately.

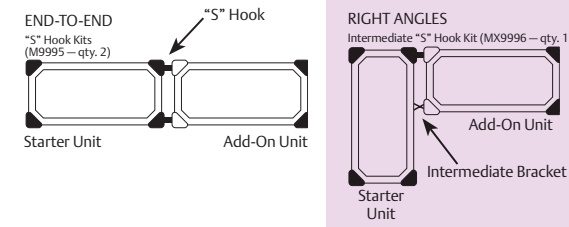

- Regular "S" Hook location
- Intermediate bracket location
- Post
- Post not required



Add-On units with "S" hooks can only be attached to shelves supported by two or more posts.



4-Tier Unit with 63" posts

| Nominal Width/Length (in.) (mm) | Approx. Pkd. Wt. (lbs.) (kg) | Cat. No. Starter Unit | Approx. Pkd. Wt. (lbs.) (kg) | Cat. No. Add-On Unit |
|---------------------------------|------------------------------|-----------------------|------------------------------|----------------------|
| 18x24 | 457x610 | 48.0 | 21.8 | X316GX3 |
| 18x30 | 457x760 | 52.0 | 23.6 | X326GX3 |
| 18x36 | 457x914 | 56.0 | 25.4 | X336GX3 |
| 18x42 | 457x1060 | 64.0 | 29.0 | X346GX3 |
| 18x48 | 457x1219 | 72.0 | 32.7 | X356GX3 |
| 18x60 | 457x1524 | 88.0 | 39.9 | X366GX3 |
| 18x72 | 457x1829 | 100.0 | 45.4 | X376GX3 |
| 24x24 | 610x610 | 54.0 | 24.5 | X516GX3 |
| 24x30 | 610x760 | 64.0 | 29.0 | X526GX3 |
| 24x36 | 610x914 | 68.0 | 30.8 | X536GX3 |
| 24x42 | 610x1060 | 76.0 | 34.5 | X546GX3 |
| 24x48 | 610x1219 | 84.0 | 38.1 | X556GX3 |
| 24x60 | 610x1524 | 92.0 | 41.7 | X566GX3 |
| 24x72 | 610x1829 | 116.0 | 52.6 | X576GX3 |

Actual Dimensions: Width: Add .25" (6mm) to nominal size. Length: Subtract .25" (6mm) from nominal size.

5-Tier Unit with 74" posts

| Approx. Pkd. Wt. (lbs.) (kg) | Cat. No. Starter Unit | Approx. Pkd. Wt. (lbs.) (kg) | Cat. No. Add-On Unit | | |
|------------------------------|-----------------------|------------------------------|----------------------|------|-----------|
| 60.0 | 27.2 | 5X317GX3 | 55.0 | 24.9 | 5AX317GX3 |
| 65.0 | 29.5 | 5X327GX3 | 60.0 | 27.2 | 5AX327GX3 |
| 70.0 | 31.8 | 5X337GX3 | 65.0 | 29.5 | 5AX337GX3 |
| 80.0 | 36.3 | 5X347GX3 | 75.0 | 34.0 | 5AX347GX3 |
| 90.0 | 40.8 | 5X357GX3 | 85.0 | 38.6 | 5AX357GX3 |
| 110.0 | 49.9 | 5X367GX3 | 105.0 | 47.6 | 5AX367GX3 |
| 125.0 | 56.7 | 5X377GX3 | 120.0 | 54.4 | 5AX377GX3 |
| 65.0 | 29.5 | 5X517GX3 | 60.0 | 27.2 | 5AX517GX3 |
| 80.0 | 36.3 | 5X527GX3 | 75.0 | 34.0 | 5AX527GX3 |
| 85.0 | 38.6 | 5X537GX3 | 80.0 | 36.3 | 5AX537GX3 |
| 95.0 | 43.1 | 5X547GX3 | 90.0 | 40.8 | 5AX547GX3 |
| 105.0 | 47.6 | 5X557GX3 | 100.0 | 45.4 | 5AX557GX3 |
| 115.0 | 52.2 | 5X567GX3 | 110.0 | 49.9 | 5AX567GX3 |
| 145.0 | 65.8 | 5X577GX3 | 140.0 | 63.5 | 5AX577GX3 |

5-Tier Unit with 74" posts (4) Grid (1) Solid Shelves

| Nominal Width/Length (in.) (mm) | Cat. No. Starter Unit | |
|---------------------------------|-----------------------|----------|
| 18x24 | 457x610 | 5X317HX3 |
| 18x36 | 457x914 | 5X337HX3 |
| 18x48 | 457x1219 | 5X357HX3 |
| 18x60 | 457x1524 | 5X367HX3 |

5-Tier Unit with 74" posts (4) Grid (1) Solid Shelves

| Nominal Width/Length (in.) (mm) | Cat. No. Starter Unit | |
|---------------------------------|-----------------------|----------|
| 24x24 | 610x610 | 5X517HX3 |
| 24x36 | 610x914 | 5X537HX3 |
| 24x48 | 610x1219 | 5X557HX3 |
| 24x60 | 610x1524 | 5X567HX3 |

Actual Dimensions: Width: Add .25" (6mm) to nominal size. Length: Subtract .25" (6mm) from nominal size.

"S" Hook Kits — {9.25} For individual shelves.



MetroMax® i "S" Hook Kit

Add on shelving to existing units using two posts instead of four. Kit includes one "S" hook and one corner adapter plug. Two kits required per storage level when configuring units end-to-end. Cat. No. M9995



MetroMax® i Intermediate "S" Hook Kit

Required when joining units at right angles with open corner and no post. Intermediate bracket connects a shelf corner to the front beam of the adjoining shelf. Kit includes one intermediate bracket, two "S" Hooks, and two corner adapter plugs. One required per storage level. Cat. No. MX9996



Corner adapter (plug) fits MetroMax i

Needed for Corner (Right Angle) Configurations

Corner Add-on "S" Hook Kits — {9.10}

For Add-on Units.



Four-tier Corner Unit
Cat. No. MXCNR4

Five-tier Corner Unit
Cat. No. MXCNR5



MetroMax® 4 Polymer Shelves — {9.22}

- All-polymer shelves with removable 6" (152mm) wide shelf mats. Includes shelf with removable shelf mats and one bag of wedges.
- Compatible on the same shelving units with MetroMax i and MetroMax Q shelves.

| Nominal Width/Length (in.) | Nominal Width/Length (mm) | Cat. No. Shelf w/ Grid Mats | Cat. No. Shelf w/ Solid Mats |
|----------------------------|---------------------------|-----------------------------|------------------------------|
| 18x24 | 457x610 | MAX4-1824G | MAX4-1824F |
| 18x30 | 457x760 | MAX4-1830G | MAX4-1830F |
| 18x36 | 457x914 | MAX4-1836G | MAX4-1836F |
| 18x42 | 457x1060 | MAX4-1842G | MAX4-1842F |
| 18x48 | 457x1219 | MAX4-1848G | MAX4-1848F |
| 18x54 | 457x1372 | MAX4-1854G | MAX4-1854F |
| 18x60 | 457x1524 | MAX4-1860G | MAX4-1860F |
| 21x24 | 530x610 | MAX4-2124G | MAX4-2124F |
| 21x30 | 530x760 | MAX4-2130G | MAX4-2130F |
| 21x36 | 530x914 | MAX4-2136G | MAX4-2136F |
| 21x42 | 530x1060 | MAX4-2142G | MAX4-2142F |
| 21x48 | 530x1219 | MAX4-2148G | MAX4-2148F |
| 21x54 | 530x1372 | MAX4-2154G | MAX4-2154F |
| 21x60 | 530x1524 | MAX4-2160G | MAX4-2160F |
| 24x24 | 610x610 | MAX4-2424G | MAX4-2424F |
| 24x30 | 610x760 | MAX4-2430G | MAX4-2430F |
| 24x36 | 610x914 | MAX4-2436G | MAX4-2436F |
| 24x42 | 610x1060 | MAX4-2442G | MAX4-2442F |
| 24x48 | 610x1219 | MAX4-2448G | MAX4-2448F |
| 24x54 | 610x1372 | MAX4-2454G | MAX4-2454F |
| 24x60 | 610x1524 | MAX4-2460G | MAX4-2460F |

Actual Dimensions: Width: Add .5" (13mm) to nominal size. Length: Subtract .06" (1.6mm) from nominal size. Maximum weight capacity evenly distributed: up to and including 48" (1219mm) long shelf, 800 lbs. (363kg); 54" (1372mm) and larger, 800 lbs. (272kg).

LEARN MORE

Removable
wash-machine friendly mats.



Polymer Posts

- Corrosion proof with built-in Microban antimicrobial product protection.

| Nominal Height (in.) | Nominal Height (mm) | Approx. Pkd. Wt. (lbs.) | Approx. Pkd. Wt. (kg) | Cat. No. Stationary Post with Leveling Foot | Cat. No. Mobile Post for Stem Caster |
|----------------------|---------------------|-------------------------|-----------------------|---|--------------------------------------|
| 9 | 228 | 0.3 | 0.15 | — | MX9UP |
| 13 | 330 | 0.5 | 0.2 | MX13P | MX13UP |
| 27 | 685 | 0.9 | 0.4 | MX27P | MX27UP |
| 33 | 838 | 1.0 | 0.5 | MX33P | MX33UP |
| 54 | 1372 | 1.6 | 0.7 | MX54P | MX54UP |
| 63 | 1600 | 1.8 | 0.8 | MX63P | MX63UP |
| 70 | 1778 | 2.0 | 0.9 | — | MX70UP |
| 74 | 1880 | 2.2 | 1.0 | MX74P | MX74UP |
| 86 | 2184 | 3.0 | 1.4 | MX86P | MX86UP |

Special height cut posts are available. Dolly applications require stationary posts. Consult your Metro representative.

Stationary

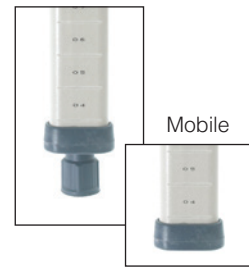

Stationary posts include a leveling foot that can be adjusted 1" (25mm).



SHELVING ASSEMBLY



MetroMax® 4 Replacement Wedges

Bag of (4)
Cat. No. MAX4-9985

For heavy loads exceeding 800 lbs.

MetroMax i shelves can be added to MetroMax 4 units.

The easiest way to customize MetroMax® in 3D.



Post Clamp

Adds stability by joining posts of two separate units together. Each unit is supported by four posts and buttressed by the adjacent unit.

Cat. No. 9994X

Foot Plate

Use to add stability to the shelving unit or to bolt units to the floor.

Cat. No. Zinc 9993Z

Cat. No. Stainless Steel 9993S

MetroMax® 4 Shelving Starter and Add-On Units {9.12}

- Starter Units consist of four polymer posts and indicated number of MetroMax 4 shelves.
- Add-On Units consist of two polymer posts, indicated number of shelves, and two "S" Hooks per shelf, for attaching add-on unit to starter unit in an end-to-end configuration. To attach shelves at right angles, Corner "S" Hook Kits must be ordered separately.

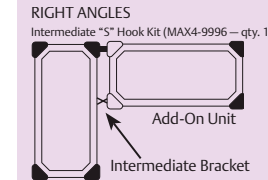
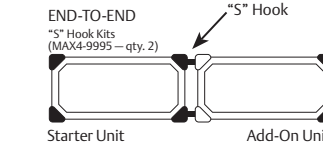

- Regular "S" Hook location
- ✗ Intermediate bracket location
- Post
- Post not required

Add-on units with "S" hooks can only be attached to shelves supported by two or more posts.



| 4-Shelf Unit 63" Posts | | |
|----------------------------|---------------------------|--|
| Nominal Width/Length (in.) | Nominal Width/Length (mm) | Cat. No. Starter Unit / Cat. No. Add-On Unit |
| 18x24 | 457x610 | X316G4 / AX316G4 |
| 18x30 | 457x760 | X326G4 / AX326G4 |
| 18x36 | 457x914 | X336G4 / AX336G4 |
| 18x42 | 457x1060 | X346G4 / AX346G4 |
| 18x48 | 457x1219 | X356G4 / AX356G4 |
| 18x54 | 457x1372 | - / - |
| 18x60 | 457x1524 | X366G4 / AX366G4 |
| 21x24 | 530x610 | X416G4 / AX416G4 |
| 21x30 | 530x760 | X426G4 / AX426G4 |
| 21x36 | 530x914 | X436G4 / AX436G4 |
| 21x42 | 530x1060 | X446G4 / AX446G4 |
| 21x48 | 530x1219 | X456G4 / AX456G4 |
| 21x54 | 530x1372 | - / - |
| 21x60 | 530x1524 | X466G4 / AX466G4 |
| 24x24 | 610x610 | X516G4 / AX516G4 |
| 24x30 | 610x760 | X526G4 / AX526G4 |
| 24x36 | 610x914 | X536G4 / AX536G4 |
| 24x42 | 610x1060 | X546G4 / AX546G4 |
| 24x48 | 610x1219 | X556G4 / AX556G4 |
| 24x54 | 610x1372 | - / - |
| 24x60 | 610x1524 | X566G4 / AX566G4 |

Actual Dimensions: Width: Add .5" (13mm) to nominal size. Length: Subtract .06" (2mm) from nominal size.

| 4-Shelf Unit 74" Posts | | | |
|------------------------|----------------------|-----------------------|----------------------|
| Cat. No. Starter Unit | Cat. No. Add-On Unit | Cat. No. Starter Unit | Cat. No. Add-On Unit |
| MF-182474G-S-4 | MF-182474G-A-4 | MF-183074G-S-4 | MF-183074G-A-4 |
| MF-183674G-S-4 | MF-183674G-A-4 | MF-184274G-S-4 | MF-184274G-A-4 |
| MF-184874G-S-4 | MF-184874G-A-4 | MF-185474G-S-4 | MF-185474G-A-4 |
| MF-186074G-S-4 | MF-186074G-A-4 | MF-212474G-S-4 | MF-212474G-A-4 |
| MF-213074G-S-4 | MF-213074G-A-4 | MF-213674G-S-4 | MF-213674G-A-4 |
| MF-214274G-S-4 | MF-214274G-A-4 | MF-214874G-S-4 | MF-214874G-A-4 |
| MF-215474G-S-4 | MF-215474G-A-4 | MF-216074G-S-4 | MF-216074G-A-4 |
| MF-242474G-S-4 | MF-242474G-A-4 | MF-243074G-S-4 | MF-243074G-A-4 |
| MF-243674G-S-4 | MF-243674G-A-4 | MF-244274G-S-4 | MF-244274G-A-4 |
| MF-244874G-S-4 | MF-244874G-A-4 | MF-245474G-S-4 | MF-245474G-A-4 |
| MF-246074G-S-4 | MF-246074G-A-4 | - | - |

| 5-Shelf Unit 74" Posts | | | |
|------------------------|----------------------|-----------------------|----------------------|
| Cat. No. Starter Unit | Cat. No. Add-On Unit | Cat. No. Starter Unit | Cat. No. Add-On Unit |
| 5X317G4 | 5AX317G4 | 5X327G4 | 5AX327G4 |
| 5X337G4 | 5AX337G4 | 5X347G4 | 5AX347G4 |
| 5X357G4 | 5AX357G4 | - | - |
| 5X367G4 | 5AX367G4 | 5X417G4 | 5AX417G4 |
| 5X427G4 | 5AX427G4 | 5X437G4 | 5AX437G4 |
| 5X447G4 | 5AX447G4 | 5X457G4 | 5AX457G4 |
| 5X467G4 | 5AX467G4 | - | - |
| 5X517G4 | 5AX517G4 | 5X527G4 | 5AX527G4 |
| 5X537G4 | 5AX537G4 | 5X547G4 | 5AX547G4 |
| 5X557G4 | 5AX557G4 | - | - |
| 5X567G4 | 5AX567G4 | - | - |



4-Shelf Starter Unit



4-Shelf Add-On Unit

Includes 8 S-Hooks

Needed for Corner (Right Angle) Configurations

Corner Add-on "S" Hook Kits — {9.12}

For Add-on Units.



Four-tier Corner Unit
Cat. No. MAX4-CNR4

Five-tier Corner Unit
Cat. No. MAX4-CNR5

"S" Hook Kits — {9.25} For individual shelves.



MetroMax® 4 Intermediate "S" Hook Kit

Required when joining units at right angles with open corner and no post. Kit includes one intermediate bracket, one "S" Hooks, and two corner adapter plugs.
Cat. No. MAX4-9996



Standard "S" Hook Kit

MetroMax® 4 "S" Hook Kit

Kit includes one "S" hook and one corner adapter plug. Two kits required per storage level when configuring units end-to-end.
Cat. No. MAX4-9995

SHELVING HEIGHT GUIDELINES

| Shelf Depth | 14" (356mm) | 18" (457mm) | 21" (533mm) | 24" (610mm) |
|-------------------------------|--------------|--------------|--------------|--------------|
| Maximum Allowable Post Height | 63" (1600mm) | 86" (2184mm) | 86" (2184mm) | 86" (2184mm) |

Note: For stationary units with foot plates or wall brackets properly attached to the floor or wall, the maximum allowable height is 86" (2184mm).



Handles

- Add handles on mobile units to improve maneuverability and ergonomics.
- Compatible with MetroMax® i, MetroMax® 4, and MetroMax® Q units.
- Corrosion-proof Type 304 stainless steel construction.



Tri-Lobal Adapters
Included with handles.

Extended Handle — {9.25}

| Fits Shelf Depth (in.) (mm) | Extension Depth (Post to Edge of Handle) (in.) (mm) | Approx. Pkd. Wt (lbs.) (kg) | i, 4, and Q Cat. No. |
|-----------------------------|---|-----------------------------|----------------------|
| 18 457 | 4.5 113 | 2.5 1.1 | MEH18S |
| 24 610 | 4.5 113 | 2.8 1.3 | MEH24S |

NOTE: Stainless steel fasteners are provided with each handle to secure the handle to the post for heavier duty applications



Tri-Lobal Adapter Replacements

Cat. No. MTLA
Bag of 4 assemblies

MTLA adapters are designed to work with MetroMax i, MetroMax 4, and MetroMax Q and are not compatible with original MetroMax.

Easy-Grip Handle — {9.25}

| Fits Shelf Depth (in.) (mm) | Extension Depth (Post to Edge of Handle) (in.) (mm) | Approx. Pkd. Wt (lbs.) (kg) | i, 4, and Q Cat. No. |
|-----------------------------|---|-----------------------------|----------------------|
| 18 457 | 6 151 | 2.5 1.1 | MERGH18S |
| 24 610 | 6 151 | 3.0 1.4 | MERGH24S |

NOTE: Stainless steel fasteners are provided with each handle to secure the handle to the post for heavier duty applications



MetroMax® Stem Casters — {9.25}

For use with either polymer or steel stem caster posts.

- Promotes easy cleaning. Casters allow shelving units to be moved easily for access to floors and walls.
- Efficient Transport: Create a cart to efficiently move supplies throughout a facility or campus.

Castors for Dry Areas



GOOD

Standard Stem Casters — {9.25}

- Plated caster horns and hardware. Bumper included with each caster.
- Swivel, Swivel with Brakes, and Rigid Caster options available.



5MPX

| Wheel Diameter (in.) (mm) | Face (in.) (mm) | Load Rating (lbs.) (kg) | Type | Wheel Tread | Temperature Range (Continuous Usage) (Fahrenheit) (Celsius) | Approx. Pkd. Wt. (lbs.) (kg) | Cat. No. | Each |
|---------------------------|-----------------|-------------------------|-------------|--------------------|---|------------------------------|----------|-------|
| 5 127 | 1 1/4 32 | 200 90 | Stem/Swivel | Resilient, Flat | -20°-160° -29°-71° | 2 1/2 1.1 | 5MX | 32.50 |
| 5 127 | 1 1/4 32 | 200 90 | Stem/Brake | Resilient, Flat | -20°-160° -29°-71° | 2 5/8 1.2 | 5MBX | 39.50 |
| 5 127 | 1 1/4 32 | 200 90 | Stem/Rigid* | Resilient, Flat | -20°-160° -29°-71° | 3 1/2 1.5 | 5MRX | 39.50 |
| 5 127 | 1 1/4 32 | 250 113 | Stem/Swivel | High Modulus Donut | -20°-180° -29°-82° | 2 1/2 1.1 | 5MDXA | 51.50 |
| 5 127 | 1 1/4 32 | 250 113 | Stem/Brake | High Modulus Donut | -20°-180° -29°-82° | 2 5/8 1.2 | 5MDBXA | 58.00 |
| 5 127 | 1 1/4 32 | 250 113 | Stem/Rigid* | High Modulus Donut | -20°-180° -29°-82° | 2 3/8 1.1 | 5MDRXA | 58.00 |
| 5 127 | 1 1/4 32 | 300 135 | Stem/Swivel | Polyurethane, Flat | -20°-180° -29°-82° | 2 1/8 0.9 | 5MPX | 32.50 |
| 5 127 | 1 1/4 32 | 300 135 | Stem/Brake | Polyurethane, Flat | -20°-180° -29°-82° | 2 1/4 1 | 5MPBX | 40.00 |
| 5 127 | 1 1/4 32 | 300 135 | Stem/Rigid* | Polyurethane, Flat | -20°-180° -29°-82° | 2 0.9 | 5MPRX | 40.00 |

*Note: Rigid casters are held in place by a connecting channel. When ordering, shelf width must be provided. Rigid connecting channel (stainless steel): Cat. No. 18RS, 21RS, or 24RS.



Castors for Wet or Corrosive Areas



BETTER



5PCX

5PCBX

Polymer Stem Casters — {9.25}

Corrosion resistance and enhanced durability. Appropriate for all medium-duty mobile applications. Bumpers included.

- All-polymer horn, stainless axle, and hardware. 5" (127mm) diameter polyurethane, flat wheel.
- Sleeve style axle bearing and optional toe-operated brake mechanism
- Antimicrobial options have a tread with built-in antimicrobial product protection.

| Wheel Diameter (in.) (mm) | Face (in.) (mm) | Load Rating (lbs.) (kg) | Type | Temperature Range (Continuous Usage) (Fahrenheit) (Celsius) | Approx. Pkd. Wt. (lbs.) (kg) | Cat. No. | Cat. No. Antimicrobial |
|---------------------------|-----------------|-------------------------|-------------|---|------------------------------|----------|------------------------|
| 5 127 | 1.25 32 | 300 135 | Stem/Swivel | -20°-120° -29°-49° | 2 0.9 | 5PCX | 5PCXM |
| 5 127 | 1.25 32 | 300 135 | Stem/Brake | -20°-120° -29°-49° | 2 0.9 | 5PCBX | 5PCBXM |
| 5 127 | 1.25 32 | 300 135 | Stem/Rigid* | -20°-120° -29°-49° | 2 0.9 | 5PCRX | — |

*Note 1: Rigid casters are held in place by a connecting channel. When ordering, shelf width must be provided. Rigid connecting channel (aluminum) for 5PCRX caster: Cat. No. P18RC, P21RC, P24RC.

Note 2: Not suitable for cart wash and autoclave applications.



BEST

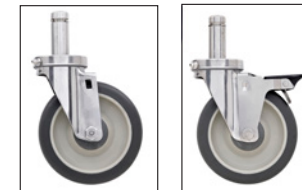

5MPXGSA

5MPBXGSA

Stainless Steel Cart-Washable Stem Casters — {9.25}

- Stainless horn, axle, and stem with sealed bearings. Bumper included with each caster.

| Wheel Diameter (in.) (mm) | Face (in.) (mm) | Load Rating (lbs.) (kg) | Type | Wheel Tread | Temperature Range (Continuous Usage) (Fahrenheit) (Celsius) | Approx. Pkd. Wt. (lbs.) (kg) | Cat. No. |
|---------------------------|-----------------|-------------------------|-------------|--------------------|---|------------------------------|----------|
| 5 127 | 1.25 32 | 300 135 | Stem/Swivel | Polyurethane, Flat | -20°-180° -29°-82° | 2.12 0.9 | 5MPXGSA |
| 5 127 | 1.25 32 | 300 135 | Stem/Brake | Polyurethane, Flat | -20°-180° -29°-82° | 2.25 1 | 5MPBXGSA |
| 5 127 | 1.25 32 | 300 135 | Stem/Rigid* | Polyurethane, Flat | -20°-180° -29°-82° | 2 0.9 | 5MPRXGSA |

*Note: Rigid casters are held in place by a connecting channel. When ordering, shelf width must be provided. Rigid connecting channel (stainless steel): Cat. No. 18RS, 21RS, or 24RS.

Rigid stem casters are often ordered two per unit for improved tracking and handling. Rigid caster channel are provided with each two rigid stem casters at no charge.

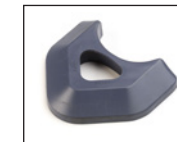

Replacement Bumper

Tri-lobal polymer or steel post.
Cat. No. M9992DBX



CASTER
INSTALLATION

METROMAX® SHELVING CARTS



MetroMax® i — Stem Caster Carts — {9.13}

- Corrosion proof shelves and posts; removable polymer mats.
- 4 shelf units consist of 4 shelves, polymer posts, wedge connectors and polyurethane casters.
- 5 shelf units consist of 5 shelves, polymer posts, wedge connectors and polyurethane casters.
- Weight Capacity of cart: models with polyurethane casters: 900 lbs. (408kg)



*Shelves & Posts Only



| Nominal Width/Length (in.) | Approx. Pkd. Wt. (lbs.) (kg) | 4-Shelf Unit | |
|----------------------------|------------------------------|---|---|
| | | Open Grid Mats 2-Swivel, 2-Brake Polyurethane Casters | Solid Mats 2-Swivel, 2-Brake Polyurethane Casters |
| 18x36 | 457x914 | 74 | 33 |
| 18x48 | 457x1219 | 86 | 38 |
| 18x60 | 457x1524 | 98 | 44 |
| 24x36 | 610x914 | 82 | 37 |
| 24x48 | 610x1219 | 98 | 44 |
| 24x60 | 610x1524 | 114 | 51 |

| Approx. Pkd. Wt. (lbs.) (kg) | 5-Shelf Solid Bottom Unit | |
|------------------------------|------------------------------|---|
| | Approx. Pkd. Wt. (lbs.) (kg) | Cat. No. 2-Swivel, 2-Brake Polyurethane Casters |
| 82 | 37 | 5X337EGX3 |
| 109 | 49 | 5X357EGX3 |
| 121 | 55 | 5X367EGX3 |
| 102 | 46 | 5X537EGX3 |
| 123 | 56 | 5X557EGX3 |
| 141 | 63 | 5X567EGX3 |



MetroMax® 4 — Stem Caster Carts — {9.12}

- Corrosion proof shelves and posts; removable polymer mats.
- 4 shelf units consist of four shelves, polymer posts, wedge connectors and polyurethane casters with polymer horns.
- 5 shelf units consist of 5 shelves, polymer posts, wedge connectors and polyurethane casters with polymer horns.
- Weight Capacity of cart: models with polyurethane casters: 750 lbs. (340kg)



*Shelves & Posts Only



| Nominal Width/Length (in.) | Approx. Pkd. Wt. (lbs.) (kg) | 4-Tier Open Grid Mats | |
|----------------------------|------------------------------|------------------------------|---|
| | | Approx. Pkd. Wt. (lbs.) (kg) | Cat. No. 2-Swivel, 2-Brake Polyurethane Casters |
| 18x36 | 457x914 | 50.6 | 22.9 |
| 18x48 | 457x1219 | 58.3 | 26.5 |
| 18x60 | 457x1524 | 66.6 | 30.2 |
| 24x36 | 610x914 | 57.2 | 25.9 |
| 24x48 | 610x1219 | 67.6 | 30.7 |
| 24x60 | 610x1524 | 77.2 | 35.0 |

| Approx. Pkd. Wt. (lbs.) (kg) | 5-Tier w/ Solid Bottom | |
|------------------------------|------------------------------|---|
| | Approx. Pkd. Wt. (lbs.) (kg) | Cat. No. 2-Swivel, 2-Brake Polyurethane Casters |
| 61.0 | 27.7 | 5X337PG4 |
| 70.7 | 32.1 | 5X357PG4 |
| 81.0 | 36.8 | 5X367PG4 |
| 69.3 | 31.4 | 5X537PG4 |
| 82.3 | 37.3 | 5X557PG4 |
| 94.3 | 42.8 | 5X567PG4 |



METROMAX® SHELVING CARTS & UTILITY CARTS



MetroMax® Q
4-Tier with Open Grid
(5-Tier available)



4-Shelf 67.31" Unit
with Open Grid Mats

| Nominal Width/Length (in.) | Nominal Width/Length (mm) | Cat. No. Polymer Caster Polyurethane Tread | Cat. No. Plated Caster Polyurethane Tread |
|----------------------------|---------------------------|--|---|
| | | | |
| 18x42 | 457x1060 | MQ-184263G-MP-4 | - |
| 18x48 | 457x1219 | MQ-184863G-MP-4 | Q356EG3 |
| 18x60 | 457x1524 | MQ-186063G-MP-4 | Q366EG3 |
| 21x36 | 530x914 | MQ-213663G-MP-4 | Q436EG3 |
| 21x42 | 530x1060 | MQ-214263G-MP-4 | - |
| 21x48 | 530x1219 | MQ-214863G-MP-4 | Q456EG3 |
| 21x60 | 530x1524 | MQ-216063G-MP-4 | Q466EG3 |
| 24x36 | 610x914 | MQ-243663G-MP-4 | Q536EG3 |
| 24x42 | 610x1060 | MQ-244263G-MP-4 | - |
| 24x48 | 610x1219 | MQ-244863G-MP-4 | Q556EG3 |
| 24x60 | 610x1524 | MQ-246063G-MP-4 | Q566EG3 |

4-Shelf 75.31" Unit
with Open Grid Mats

| Cat. No. Polymer Caster Polyurethane Tread | Cat. No. Plated Caster Polyurethane Tread |
|--|---|
| | |
| MQ-184870G-MP-4 | MQ-186070G-MP-4 |
| MQ-213670G-MP-4 | MQ-214270G-MP-4 |
| MQ-214870G-MP-4 | MQ-216070G-MP-4 |
| MQ-243670G-MP-4 | MQ-244270G-MP-4 |
| MQ-244870G-MP-4 | MQ-246070G-MP-4 |

5-Shelf 79.31" Unit
with Open Grid Mats

| Cat. No. Polymer Caster Polyurethane Tread | Cat. No. Plated Caster Polyurethane Tread |
|--|---|
| | |
| MQ-184874G-MP-5 | 5Q357EG3 |
| MQ-186074G-MP-5 | 5Q367EG3 |
| MQ-243674G-MP-5 | 5Q537EG3 |
| MQ-244874G-MP-5 | 5Q557EG3 |
| MQ-246074G-MP-5 | 5Q567EG3 |

MetroMax® Q — Stem Caster Cart, Open Grid Shelves — {9.12}

- Quick adjust shelves with removable polymer shelf mats.
- 4 shelf units consist of 4 open grid shelves, polymer posts, wedge connectors, and choice of rust resistant or general purpose casters (2) Swivel (2) Brake.
- 5 shelf units consist of 4 open grid shelves, 1 solid shelf, polymer posts, wedge connectors, and choice of rust resistant or general purpose casters (2) Swivel (2) Brake.
- Mobile cart weight capacity rated at 900 lbs. (408kg). All casters have a polyurethane tread.



*Shelves Only. Posts are Lifetime.



Solid bottom shelf and 5PCX/5PCBX casters

MetroMax® i — Utility Carts

- Corrosion proof shelves, polymer posts, and Type 304 stainless steel handle.
- Corrosion resistant 5PCX casters with 5" (127mm) polyurethane wheels, polymer horns, and stainless steel axles.
- 39.25" (997mm) tall. Weight capacity of cart: 900 lbs. (408kg) evenly distributed.

| Nominal Width/Length (in.) | Nominal Width/Length (mm) | Actual Width/Length (in.) | Actual Width/Length (mm) | Description | Approx. Pkd. Wt. (lbs.) (kg) | | Cat. No. | |
|----------------------------|---------------------------|---------------------------|--------------------------|-------------|------------------------------|---------|----------|--------------|
| | | | | | 18x30 | 457x760 | | 20.31 |
| 24x36 | 610x914 | 26.31 | 40.5 | 668 x 1029 | 2-shelf | 46.0 | 20.5 | MXUC2436G-25 |
| 18x30 | 457x760 | 20.31 | 34.5 | 516 x 876 | 3-shelf | 46.0 | 20.5 | MXUC1830G-35 |
| 24x36 | 610x914 | 26.31 | 40.5 | 668 x 1029 | 3-shelf | 61.5 | 27.5 | MXUC2436G-35 |

MetroMax® Q — Utility Carts

- Quick adjust corrosion resistant shelves and polymer posts.
- Corrosion proof Type 304 stainless steel handle.
- Includes four 5PCX casters with 5" (127mm) polyurethane wheels.
- 39.25" (997mm) tall. Weight capacity of cart: 900 lbs. (408kg) evenly distributed.

| Nominal Width/Length (in.) | Nominal Width/Length (mm) | Actual Width/Length (in.) | Actual Width/Length (mm) | Description | Approx. Pkd. Wt. (lbs.) (kg) | | Cat. No. | |
|----------------------------|---------------------------|---------------------------|--------------------------|-------------|------------------------------|---------|----------|--------------|
| | | | | | 18x30 | 457x760 | | 20.31 |
| 24x36 | 610x914 | 26.31 | 40.5 | 668 x 1029 | 2-shelf | 46.0 | 20.5 | MQUC2436G-25 |
| 18x30 | 457x760 | 20.31 | 34.5 | 516 x 876 | 3-shelf | 46.0 | 20.5 | MQUC1830G-35 |
| 24x36 | 610x914 | 26.31 | 40.5 | 668 x 1029 | 3-shelf | 61.5 | 27.5 | MQUC2436G-35 |





ECP55CX3 — Standard (Par Level)



ECT55CX3 — Standard Transport/Exchange



ECT55DX3 — Deluxe Transport/Exchange

MetroMax® i Exchange Carts

MetroMax polymer carts provide a smooth surface that won't snag sterile packs or sealed supplies. The shelves also contain Microban antimicrobial protection that keeps the shelves cleaner between cleanings (see metro.com/what-is-microban). Carts within each series (as noted) feature dividers, ledges, enclosure panels, MetroMax slides and tote boxes in various combinations all of which can be removed and reconfigured to adapt to changes in supply, volume, and packaging.

Par Level/Stock

For moveable storage of supplies in nursing units and other functional departments. Par Level carts utilize stem casters to provide a smaller footprint for more efficient space utilization in storage areas.

Standard

Includes four open grid shelves, one solid bottom shelf, polymer posts, four polyurethane stem casters (2 with brakes) and six label holders.

| Shelf Width/Length (in./mm) | Overall Height (in./mm) | Cat. No. |
|-----------------------------|-------------------------|----------|
| 18x48 457x1219 | 67.31 1710 | ECP35CX3 |
| 18x60 457x1524 | 67.31 1710 | ECP36CX3 |
| 24x48 610x1219 | 67.31 1710 | ECP55CX3 |
| 24x60 610x1524 | 67.31 1710 | ECP56CX3 |

Deluxe

Includes four open grid shelves, one solid bottom shelf, polymer posts, four polyurethane stem casters (2 with brakes), side and back enclosure panels, MetroMax tote slides, 6" (152mm) deep tote boxes with dividers, shelf dividers and twelve label holders.

| Shelf Width/Length (in./mm) | Overall Height (in./mm) | Tote Boxes 6" (152mm) Deep | Shelf Dividers | Super Slides | Cat. No. |
|-----------------------------|-------------------------|----------------------------|----------------|--------------|----------|
| 24x48 610x1219 | 67.31 1710 | 2 | 4 | 1 | ECP55DX3 |
| 24x60 610x1524 | 67.31 1710 | 4 | 6 | 2 | ECP56DX3 |

Transport/Exchange

For transport and exchange of supplies or linens from Central Supply or the Laundry to nursing units and other functional departments. Transport carts utilize a dolly base to endure the rigors encountered in the daily distribution of products throughout healthcare facilities.

Standard

Includes four open grid shelves, one solid bottom shelf, polymer posts, aluminum dolly frame with wraparound bumper, 8" (203mm) high modulus donut casters (two with swivel-locks), and six label holders.

| Shelf Width/Length (in./mm) | Overall Height (in./mm) | Cat. No. |
|-----------------------------|-------------------------|----------|
| 24x48 610x1219 | 71.94 1827 | ECT55CX3 |
| 24x60 610x1524 | 71.94 1827 | ECT56CX3 |

Deluxe

Includes four open grid shelves, one solid bottom shelf, polymer posts aluminum dolly frame with wraparound bumper, 8" (203mm) high modulus donut casters (two with swivel-locks), side and back enclosure panels, MetroMax tote slides, 6" (152mm) deep tote boxes with dividers, shelf dividers and twelve label holders.

| Shelf Width/Length (in./mm) | Overall Height (in./mm) | Tote Boxes 6" (152mm) Deep | Shelf Dividers | Super Slides | Cat. No. |
|-----------------------------|-------------------------|----------------------------|----------------|--------------|----------|
| 24x48 610x1219 | 71.94 1827 | 2 | 4 | 1 | ECT55DX3 |
| 24x60 610x1524 | 71.94 1827 | 4 | 6 | 2 | ECT56DX3 |

Indicates antimicrobial product.



Extended Handles for MetroMax® i Mobile Systems — {9.25}

These contoured stainless steel handles attach easily to 18" or 24" (457 or 610mm) MetroMax® carts, dolly trucks and other mobile applications.

| Fits Unit Width (in./mm) | Approx. Pkd. Wt. (lbs./kg) | Cat. No. |
|--------------------------|----------------------------|----------|
| 18 457 | 2.25 1.0 | MEH18S |
| 24 610 | 2.5 1.1 | MEH24S |



Extended Handle

MetroMax i® Supply Storage System

Baskets have semi-open front for easy access. Dividers adjust horizontally within the basket to accept various size items. Continuous label holders identify basket contents.

| Description | Height/Width/Length (in./mm) | Total Baskets Per Cart | Casters | Cat. No. |
|--------------------------|------------------------------|------------------------|---------|----------|
| Open Cart | 24x24x60 610x610x1524 | 4 | * | MXIV1 |
| Open Cart with Top Shelf | 24x24x69 610x610x1753 | 4 | * | MXIV2 |
| Open Cart | 24x42x60 610x1066x1524 | 8 | † | MXIV4 |
| Open Cart with Top Shelf | 24x42x69 610x1066x1753 | 8 | † | MXIV5 |
| Open Cart | 24x60x60 610x1524x1524 | 12 | † | MXIV6 |
| Open Cart with Top Shelf | 24x60x69 610x1524x1753 | 12 | † | MXIV7 |

*Four 5" (127mm) poly casters; two swivel, two with brakes.
†5" (127mm) poly casters on dolly frame; two swivel, one swivel with brake, and one rigid.

Accessories

| Description | Size (in./mm) | Cat. No. |
|---------------------------|--------------------------|----------|
| Basket* with Label Holder | 18.5x24.5x10 470x622x254 | IVB1 |
| Divider | 9 229 | IVBD |

*Basket weight capacity is 35 lbs. (16kg).



Perfect for: **Healthcare** Exchange System, Par Level Storage, Bulk Storage in Central Supply, Pharmacy Admix-ture, I.C.U. and E.R. Storage.

MXIV1 (includes accessories as shown)



IVB1 (shown with optional Divider)



Baskets fit on frames level or at a 10° angle.



Organize with accessories.

Organize supplies to improve operational efficiencies.

- Well-organized storage results in fewer expired supplies and less waste.
- Innovative shelf and accessory designs have smooth surfaces that protect vacuum sealed and other packaged items from damage.
- Flexible compartments help sort supplies for faster access and maximize the use of storage space.

A Dividers **B** Ledges **C** Enclosure Panels **D** Metro Totes **E** Metro Bins

Flexible Compartments

Dividers and Ledges can be used to create flexible compartments that most efficiently use available storage space. When combined with open grid shelves this minimizes dust accumulation.

Bins offer removable compartmentalized storage for easy access or as part of an exchange system. See page 72 for Bin options.

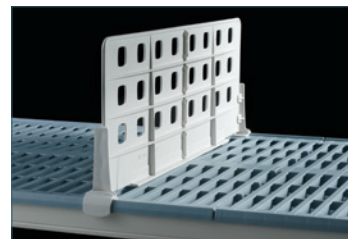

8" (203mm) Shelf Dividers — Standard Duty — {9.25}

- Use to create organized compartments or to simply separate shelf contents.
- Easily repositioned on grid and solid shelves.
- Corrosion-proof polymer (high-density polypropylene).
- Three-piece design — Ships assembled.

| Nominal Length (in.) (mm) | i, 4, and Q | | |
|---------------------------------|-------------|------------|----------|
| | Cat. No. | Cat. No. | Cat. No. |
| 18 457 | MXD18-8 | MAX4-D18-8 | MQD18-8 |
| 24 610 | MXD24-8 | MAX4-D24-8 | MQD24-8 |

*Note: Can be retrofitted to original MetroMax and MetroMax Q.



Universal Shelf Dividers — Light Duty, for open grid shelves — {9.25}

- For use with grid shelves (MetroMax i, MetroMax 4, MetroMax Q, and Super Erecta Pro), Super Erecta wire shelves, and Super Adjustable wire shelves.
- Easiest divider to install.
- Maximum flexibility: Can be repositioned along the entire shelf.
- Each divider includes a panel and two clips to connect to any open grid or wire shelf. Does not attach to solid shelves.
- Corrosion proof.

8" (203mm) Divider

| Nominal Length (in.) (mm) | Fits Shelf Depth | Approx. Pkd. Wt. | | i, 4, and Q Cat. No. |
|---------------------------------|-----------------------|------------------|------|-------------------------|
| | | (lbs.) | (kg) | |
| 18 457 | 18", 21" (457, 530mm) | 1.3 | 0.6 | MUD18-8 |
| 24 610 | 24" (610mm) | 1.6 | 0.7 | MUD24-8 |

*Note: Can be retrofitted to original MetroMax and MetroMax Q.
Additional clips: Cat. No DCLIP, 2 per bag.



Universal 4" (102mm) Shelf Dividers — {9.25}

- Maximum flexibility: Can be repositioned along the entire shelf.
- Three-piece design; clips connect to any open grid or wire shelf; divider panel then drops into place. Does not attach to solid shelves.
- Corrosion-proof polymer (high-density polypropylene).

| Cat No. | Fits Shelf Depth | Nominal Height | | Nominal Length | | Sold as |
|-------------|------------------|----------------|------|----------------|------|---------|
| | | (in.) | (mm) | (in.) | (mm) | |
| MUD24H4-4PK | 24" (610mm) | 4 | 102 | 24 | 610 | 4 Pack |

Shelf-to-Shelf Dividers — {9.25}

- Full height dividers efficiently compartmentalize the space between two shelves
- Smooth surfaces protect packaged items from damage.
- Corrosion proof.
- Compatible with open grid polymer shelves, Super Erecta wire shelves, and Super Adjustable wire shelves. Does not work with solid shelves.

| Fits Shelf Depth (in.) (mm) | Nominal Height (in.) (mm) | Approx. Pkd. Wt. | | i, 4, and Q Cat. No. |
|-----------------------------------|---------------------------------|------------------|------|-------------------------|
| | | (lbs.) | (kg) | |
| 18, 21 | 457, 530 | 2.3 | 1.0 | MD18-16 |
| 18, 21 | 457, 530 | 2.5 | 1.1 | MD18-20 |
| 18, 21 | 457, 530 | 3.8 | 1.7 | MD18-24 |
| 24 | 610 | 2.8 | 1.2 | MD24-16 |
| 24 | 610 | 3.0 | 1.3 | MD24-20 |
| 24 | 610 | 4.4 | 2.0 | MD24-24 |

*Note: Can be retrofitted to original MetroMax and MetroMax Q shelves.
*Note: -16 parts have three panels, -20 parts have four panels, -24 parts have five panels.

2" (51mm) Stackable Shelf Ledges — {9.25}

- Prevent items from falling off shelves.
- Snap on and off quickly. Easily stacked to contain larger items.
- Corrosion proof polymer (high-density polypropylene) and Type 304 stainless steel.
- Ships assembled.

| Nominal Length (in.) (mm) | Type | i, 4, and Q | | |
|---------------------------------|------|-------------|--------------|-----------|
| | | Cat. No. | Cat. No. | Cat. No. |
| 18 457 | Side | MXLS18-2S | MAX4-LS18-2S | MQLS18-2S |
| 21 530 | Side | — | MAX4-LS21-2S | MQLS21-2S |
| 24 610 | Side | MXLS24-2S | MAX4-LS24-2S | MQLS24-2S |
| 24 610 | Back | MXL24-2S | MAX4-L24-2S | MQL24-2S |
| 30 760 | Back | MXL30-2S | MAX4-L30-2S | MQL30-2S |
| 36 914 | Back | MXL36-2S | MAX4-L36-2S | MQL36-2S |
| 42 1066 | Back | MXL42-2S | MAX4-L42-2S | MQL42-2S |
| 48 1219 | Back | MXL48-2S | MAX4-L48-2S | MQL48-2S |
| 54 1370 | Back | MXL54-2S | MAX4-L54-2S | MQL54-2S |
| 60 1524 | Back | MXL60-2S | MAX4-L60-2S | MQL60-2S |
| 72 1829 | Back | MXL72-2S | — | MQL72-2S |

*Note: MetroMax i wire ledges can be retrofitted to original MetroMax.
*Note: MetroMax Q wire ledges (MQ-) cannot be retrofitted to original MetroMax Q.

4" (102mm) Solid Clear Stackable Shelf Ledges — {9.26}

- Solid design helps contain small items.
- Clear plastic allows light penetration and visible access to supplies.
- Corrosion proof.
- Ships assembled.

| Nominal Length (in.) (mm) | Type | Approx. Pkd. Wt. | | i, 4, and Q | |
|---------------------------------|------|------------------|------|-------------|--------------|
| | | (lbs.) | (kg) | Cat. No. | Cat. No. |
| 18 457 | Side | 0.5 | 0.2 | MXLS18-4P | MAX4-LS18-4P |
| 24 610 | Side | 0.5 | 0.2 | MXLS24-4P | MAX4-LS24-4P |
| 24 610 | Back | 0.5 | 0.2 | MXL24-4P | MAX4-L24-4P |
| 36 914 | Back | 1.00 | 0.4 | MXL36-4P | MAX4-L36-4P |
| 48 1219 | Back | 1.25 | 0.6 | MXL48-4P | MAX4-L48-4P |
| 60 1524 | Back | 1.75 | 0.8 | MXL60-4P | MAX4-L60-4P |

Note: Not suitable for cart-wash applications.

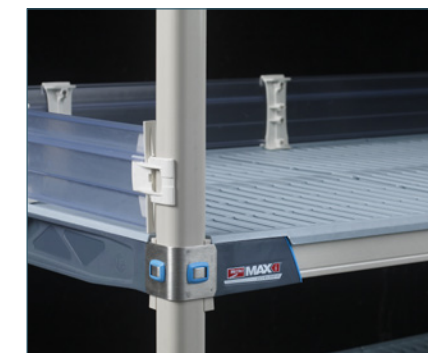
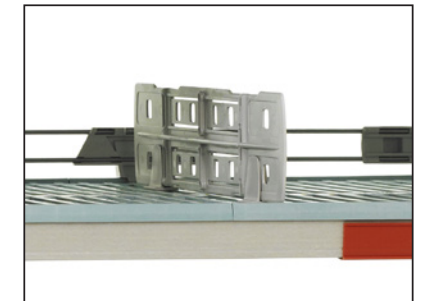



Contain it.

Efficiently enclose and contain with Enclosure Panels.

Enclosure Panels — {9.25}

- An efficient way of enclosing the sides and back of all shelves in a unit to contain stored contents.
- Slot opening: 3" W x 3.87" H.
- Designed to work with MetroMax® i, MetroMax® 4, and MetroMax® Q shelves. Mounting clips included.

Use shelf to shelf dividers with enclosure panels to create full height compartments to organize bulky, hard-to-handle supplies.

| Actual Width/Height (in./mm) | | Post Height (in./mm) | | For use with Shelf Width (in./mm) | | Approx. Pkd. Wt. (lbs./kg) | | i, 4, and Q Cat. No. |
|------------------------------|------------|----------------------|------|-----------------------------------|----------|----------------------------|-----|----------------------|
| 12.37 x 51.25 | 315 x 1300 | 54 | 1370 | 18 | 457 | 6.25 | 2.8 | MEP35E |
| 12.37 x 59.25 | 315 x 1505 | 63 | 1600 | 18 | 457 | 7 | 3.2 | MEP36E |
| 12.37 x 71.25 | 315 x 1810 | 74 | 1880 | 18 | 457 | 8.75 | 4.0 | MEP37E |
| 18.37 x 51.25 | 467 x 1300 | 54 | 1370 | 21, 24 | 530, 610 | 9 | 4.1 | MEP55E |
| 18.37 x 59.25 | 467 x 1505 | 63 | 1600 | 21, 24 | 530, 610 | 10.25 | 4.7 | MEP56E |
| 18.37 x 71.25 | 467 x 1810 | 74 | 1880 | 21, 24 | 530, 610 | 11.75 | 5.3 | MEP57E |

*Note: Can be retrofitted to original MetroMax and MetroMax Q shelving.

| Post Height | Panels Required to Enclose Both Ends of the Shelving Unit or Cart | | |
|--------------|---|-------------|-------------|
| | 14"/18" (355mm/457mm) | 21" (530mm) | 24" (610mm) |
| 54" (1370mm) | (2) MEP35E | (2) MEP55E | (2) MEP55E |
| 63" (1600mm) | (2) MEP36E | (2) MEP56E | (2) MEP56E |
| 74" (1880mm) | (2) MEP37E | (2) MEP57E | (2) MEP57E |

Configuration Notes

1. Handles and enclosure panels can be used on the same end of the cart. Please note the following details: 21" (530mm) wide units: use the 12.37" (315mm) wide panel on the same end as the handle.
2. Top-Track: When using on the ends of a Top-Track mobile unit the enclosure panel must be mounted so that it does not interfere with the overhead tracks. Mobile posts on Top-Track are 74" (1880mm). The standard panels for a 63" post are recommended.

| Post Height | Panels Required to Enclose Back of Shelving Unit or Cart | | | | | | |
|--------------|--|--------------------------|--------------|--------------------------|--------------------------|--------------|--------------------------|
| | 30" (760mm) | 36" (914mm) | 42" (1066mm) | 48" (1219mm) | 54" (1370mm) | 60" (1524mm) | 72" (1825mm) |
| 54" (1370mm) | (2) MEP35E | (1) MEP35E (1) MEP55E | (2) MEP55E | (2) MEP35E (1) MEP55E | (1) MEP35E (2) MEP55E | (3) MEP55E | (1) MEP35E (3) MEP55E |
| 63" (1600mm) | (2) MEP36E | (1) MEP36E (1) MEP56E | (2) MEP56E | (2) MEP36E (1) MEP56E | (1) MEP36E (2) MEP56E | (3) MEP56E | (1) MEP36E (3) MEP56E |
| 74" (1880mm) | (2) MEP37E | (1) MEP37E (1) MEP57E | (2) MEP57E | (2) MEP37E (1) MEP57E | (1) MEP37E (2) MEP57E | (3) MEP57E | (1) MEP37E (3) MEP57E |

MetroMax® i Mounting Clip Replacements
 Bag of 8
 Cat. No. RPMX3-RODTAB



MetroMax® 4 Mounting Clip Replacements
 Bag of 8
 Cat. No. RPMX4-RODTAB

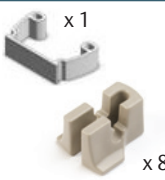
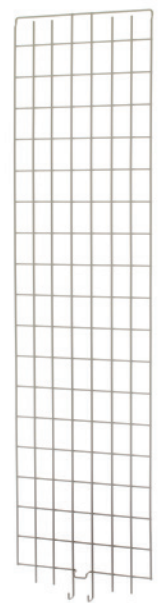

MetroMax® Q Mounting and Bottom Adapter Clip Replacements
 Bag of 8
 Cat. No. RPMQ3-RODTAB

Enclosure Panel



Find it.

Label Holders

- Plastic holders snap onto shelf edge to accommodate 1" (25mm) tall adhesive label. Label not included.
- i, 4, and Q versions available.
- Optional label holder covers exist for MetroMax Q models. Cover snaps onto the label holder to hold a non-adhesive label in place or to protect any label from dirt and moisture.



MetroMax® i Label Holder — {9.25}

Designed to accept label cards or adhesive labels. Slot measures approximately 1.25" (32mm).

| Actual Length (in./mm) | Fits Shelf Length (in./mm) | Approx. Pkd. Wt. (lbs./kg) | | Cat. No. Label Holder |
|------------------------|----------------------------|----------------------------|-----|-----------------------|
| 4.50 114 | All | .03 | .01 | 9989PX |
| 11.28 285 | 24 610 | .14 | .06 | 9989X1 |
| 23.28 590 | 36 914 | .30 | .13 | 9989X3 |
| 35.28 895 | 48 1219 | .40 | .18 | 9989X5 |



MetroMax® i Label Holder

MetroMax® Q Label Holder — {9.25}

Designed to accept label cards or adhesive labels. Slot measures approximately 1.25" (32mm).

| Actual Length (in./mm) | Fits Shelf Length (in./mm) | Approx. Pkd. Wt. (lbs./kg) | | Cat. No. Label Holder |
|------------------------|----------------------------|----------------------------|-----|-----------------------|
| 4 102 | All | .03 | .01 | MQ04LH |
| 15.44 392 | 24 610 | .14 | .06 | MQ24LH |
| 27.44 697 | 36 914 | .30 | .13 | MQ36LH |
| 39.44 1002 | 48 1219 | .40 | .18 | MQ48LH |
| 51.44 1307 | 60 1524 | .50 | .22 | MQ60LH |
| 63.44 1611 | 72 1825 | .60 | .27 | MQ72LH |



MetroMax® Q Label Holder

MetroMax® 4 Label Holder — {9.25}

Designed to accept label cards or adhesive labels. Slot measures approximately 1" (25mm).

| Actual Length (in./mm) | Fits Shelf (in./mm) | Approx. Pkd. Wt. (lbs./kg) | | 4 Cat. No. |
|------------------------|---------------------|----------------------------|-----|-------------|
| 4 102 | All | .03 | .01 | MAX4-9989PX |



MetroMax® 4 Label Holder

Color Shelf Markers — {9.25}

- Attach easily to shelf for content identification.
- Use to assign color coding to individual shelf levels, shelving units, carts, or storage areas.
- i and Q versions available.
- 6" (152mm) length.

| Shelf Marker Color | Approx. Pkd. Wt. (lbs./kg) | | i Cat. No. | Q Cat. No. |
|--------------------|----------------------------|------|------------|------------|
| | Blue | 0.05 | 0.02 | CSM6-BX |
| Green | 0.05 | 0.02 | CSM6-GX | CSM6-GQ |
| Red | 0.05 | 0.02 | CSM6-RX | CSM6-RQ |
| Tan | 0.05 | 0.02 | CSM6-TX | CSM6-TQ |
| White | 0.05 | 0.02 | CSM6-WX | CSM6-WQ |
| Yellow | 0.05 | 0.02 | CSM6-YX | CSM6-YQ |
| Gray | 0.05 | 0.02 | CSM6-GRX | CSM6-GRQ |

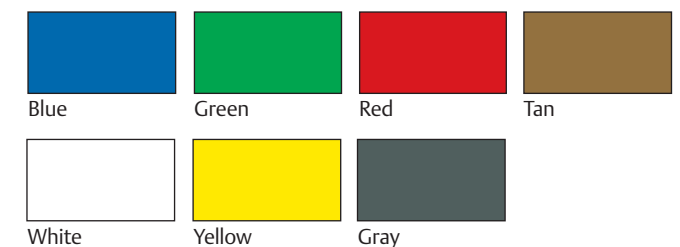

MetroMax® i Color Shelf Marker



Totes sold separately

Super Slide — {9.25}

- Designed to fit a 24" (610mm) wide shelf.
- Easily attaches to the shelf frame (under the mats) and is sized to hold 3", 5", 6", and 8" (76, 127, 152, 203mm) tall tote boxes (sold separately).
- MetroMax® i and MetroMax 4 models available.
- Corrosion resistant taupe epoxy finish with Microban antimicrobial product protection.

| Width | | Length | | Height | | Approx. Pkd. Wt. | | i | 4 |
|-------|------|--------|------|--------|------|------------------|------|---------------|------------------|
| (in.) | (mm) | (in.) | (mm) | (in.) | (mm) | (lbs.) | (kg) | Cat. No. | Cat. No. |
| 20.4 | 520 | 21.6 | 550 | 10.3 | 260 | 5.3 | 2 | MXSS2E | MAX4-SS2E |



Adjustable Slides — {9.25}

- Slides can be adjusted left to right to accommodate a variety of pan, tray, and container sizes.
- MetroMax® i and Q models available.
- Corrosion resistant taupe epoxy finish with Microban antimicrobial product protection.
- Shelves must be spaced 20" (508mm) apart.
- Can be used in conjunction with 20" (508mm) tall shelf-to-shelf dividers.

| Fits Shelf Width | | Type | Approx. Pkd. Wt. | | i | Q |
|------------------|------|------------|------------------|------|---------------|---------------|
| (in.) | (mm) | | (lbs.) | (kg) | Cat. No. | Cat. No. |
| 24 | 610 | Adjustable | 12.75 | 6 | MX24SE | MQ24SE |



Can Rack System — {9.25}

- Front loading, front dispensing can rack holds eight #10 cans or twelve #5 cans.
- Tough, corrosion resistant taupe epoxy finish with Microban antimicrobial product protection.
- Designed to fit a 24" (610mm) wide shelf.
- Mounts on any MetroMax® i or MetroMax Q shelf.

| Width/Length/Height | | Approx. Pkd. Wt. | | i and Q |
|---------------------|-------------|------------------|------|--------------|
| (in.) | (mm) | (lbs.) | (kg) | Cat. No. |
| 7.87x25.31x15 | 200x643x381 | 10 | 4.5 | CR24E |



Storage Level Frames — {9.25}

- Open four-sided frames accommodate drop-in accessories including wire baskets and stainless drying racks.
- Includes corrosion proof MetroMax i frame and a bag of wedges.
- Can be mounted on MetroMax i, MetroMax 4, and MetroMax Q shelving units.

| Nominal Exterior Length | | Frame Interior Width/Length | | Approx. Pkd. Wt. | | Cat. No. |
|-------------------------|------|-----------------------------|------|------------------|----------|----------------|
| (in.) | (mm) | (in.) | (mm) | (lbs.) | (kg) | |
| 18 | 457 | 36 | 914 | 18x32 | 457x810 | M4F1836 |
| 24 | 610 | 24 | 610 | 24x20 | 610x510 | M4F2424 |
| 24 | 610 | 36 | 914 | 24x32 | 610x810 | M4F2436 |
| 24 | 610 | 42 | 1060 | 24x38 | 610x965 | M4F2442 |
| 24 | 610 | 48 | 1220 | 24x44 | 610x1120 | M4F2448 |
| 24 | 610 | 60 | 1524 | 24x56 | 610x1370 | M4F2460 |

Note: Any MetroMax i shelf can be converted to an open storage level frame. Simply remove the shelf mats and center beam to create an open frame.

Wire Baskets — {9.25}

- Conveniently hold small items.
- 9" (229mm) deep with built in storage handles allow easy removal.
- Installs flat. Mount to a MetroMax i storage level frame. Retrofits to a MetroMax i shelf or MetroMax 4 shelf.
- Corrosion resistant taupe epoxy finish with a weight capacity of 50 lbs. (23kg)

| Nominal Width/Length | | Cat. No. |
|----------------------|---------|-----------------|
| (in.) | (mm) | |
| 14x16 | 610x406 | MB2416XE |
| 24x22 | 610x610 | MB2422XE |



NOTE: Wire baskets can be retrofitted to MetroMax i or MetroMax 4 shelves.
MetroMax i: Remove the mats & center beams and drop in the baskets.
MetroMax 4: Remove the mats and drop in the baskets.

Wire baskets can fit a MetroMax 4 shelf. Left to right the baskets will not exactly fill the space. Use a MetroMax i frame for perfect fit.

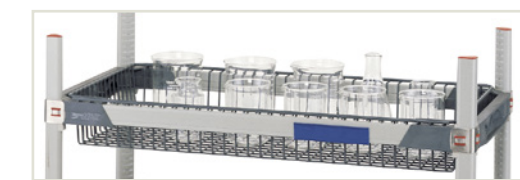

Glassware Handling Basket

Vinyl coated. Fits 18 x 36" (457 x 914mm) MetroMax i frame.

Cat. No. **GWBSKT36**
 See Spec Sheet 52.01 for detail.
 Not NSF listed.

3-Sided frames

- 1" (25mm) x 1.5" (38mm) structural steel tubing. Includes tri-lobal adapters to attach to posts. (Replacement adapters: Cat. No. MTLA bag of 4)
- Corrosion resistant epoxy finish.
- Use when configuring work tables or as a 3-sided ledge to contain bulky items.

| Nominal Width/Length | | Cat. No. i, 4, Q |
|----------------------|----------|------------------|
| (in.) | (mm) | |
| 18x60 | 355x1524 | M3TF1860E |
| 24x24 | 610x610 | M3TF2424E |
| 24x30 | 610x760 | M3TF2430E |
| 24x36 | 610x914 | M3TF2436E |
| 24x42 | 610x1066 | M3TF2442E |
| 24x48 | 610x1219 | M3TF2448E |
| 24x54 | 610x1370 | M3TF2454E |
| 24x60 | 610x1524 | M3TF2460E |





LEARN MORE

Take drying to the max.



MetroMax i Drying Rack — {9.31}



Drip Tray Mobile Drying Rack Units

Combine the corrosion protection and strength of MetroMax i with the convenience of a drying rack unit that efficiently sorts and holds items while they dry to prevent wet nesting.

Three Tray Racks (three tier unit)

| Model No. | Nominal Width (in.) | Nominal Width (mm) | Nominal Length (in.) | Nominal Length (mm) | Nominal Height (in.) | Nominal Height (mm) |
|-------------|---------------------|--------------------|----------------------|---------------------|----------------------|---------------------|
| PR36VX2-XDR | 24 | 610 | 36 | 914 | 68 | 1702 |
| PR48VX2-XDR | 24 | 610 | 48 | 1219 | 68 | 1702 |

Two SS Drop-ins, One Tray Rack, One Bulk Shelf (4-tier)

| Model No. | Nominal Width (in.) | Nominal Width (mm) | Nominal Length (in.) | Nominal Length (mm) | Nominal Height (in.) | Nominal Height (mm) |
|-------------|---------------------|--------------------|----------------------|---------------------|----------------------|---------------------|
| PR36VX3-XDR | 24 | 610 | 36 | 914 | 68 | 1702 |
| PR48VX3-XDR | 24 | 610 | 48 | 1219 | 68 | 1702 |

Two Tray Racks and Two Pan Racks (4-tier)

| Model No. | Nominal Width (in.) | Nominal Width (mm) | Nominal Length (in.) | Nominal Length (mm) | Nominal Height (in.) | Nominal Height (mm) |
|-------------|---------------------|--------------------|----------------------|---------------------|----------------------|---------------------|
| PR36VX4-XDR | 24 | 610 | 36 | 914 | 68 | 1702 |
| PR48VX4-XDR | 24 | 610 | 48 | 1219 | 68 | 1702 |

Note: For the actual dimensions for mobile units, add 2" (51mm) to the nominal dimension to account for the bumpers.



Open-Air Design

Wet floors can be hazardous to employees. Minimize water on the floor from dripping items by containing and funneling water into a standard steam pan (not included).



PLAY VIDEO



PR36VX2-XDR

Consists of (3) shelf frames, (4) 63" (1600mm) mobile posts, (4) corrosion resistant polymer casters (two swivel, two brake), (3) tray racks, and (1) drip tray.



PR36VX3-XDR

Consists of (3) shelf frames, (1) shelf, (4) 63" (1600mm) posts, (4) corrosion resistant polymer casters (two swivel, two brake), (2) stainless steel drop-in racks, (1) tray rack (1) drip tray.



PR36VX4-XDR

Consists of (4) shelf frames, (4) 63" (1600mm) posts, (4) corrosion resistant polymer casters (two swivel, two brake), (2) tray racks, (2) steam pan racks, (1) drip tray.



MetroMax i Drying Rack — {9.31}

Drying Racks Units without drip trays

| Mobile Model No. | Nominal Width (in.) | Nominal Width (mm) | Nominal Length (in.) | Nominal Length (mm) | Nominal Height (in.) | Nominal Height (mm) |
|------------------|---------------------|--------------------|----------------------|---------------------|----------------------|---------------------|
| PR48VX3 | 24 | 610 | 48 | 1219 | 68 | 1702 |
| PR48VX4 | 24 | 610 | 48 | 1219 | 68 | 1702 |

| Stationary Model No. | Nominal Width (in.) | Nominal Width (mm) | Nominal Length (in.) | Nominal Length (mm) | Nominal Height (in.) | Nominal Height (mm) |
|----------------------|---------------------|--------------------|----------------------|---------------------|----------------------|---------------------|
| PR48X3 | 24 | 610 | 48 | 1219 | 74 | 1880 |
| PR48X4 | 24 | 610 | 48 | 1219 | 74 | 1880 |

Note: For the actual dimensions for mobile units, add 2" (51mm) to the nominal dimension to account for the bumpers.



MOST POPULAR

PR48VX3

Consists of (2) shelf frames, (2) shelves, (4) 63" (1600mm) posts, (4) corrosion resistant polymer casters (two swivel, two brake), (1) tray rack, and (2) stainless steel drop-ins.



SHELVING ASSEMBLY



MetroMax 4 Drying Rack — {9.32}



Mobile Drying Rack Units

Combine the corrosion protection and strength of MetroMax i with the convenience of a drying rack unit that efficiently sorts and holds items while they dry to prevent wet nesting.

Three Tray Racks (three tier unit)

| Model No. | Nominal Width (in.) | Nominal Width (mm) | Nominal Length (in.) | Nominal Length (mm) | Nominal Height (in.) | Nominal Height (mm) |
|--------------|---------------------|--------------------|----------------------|---------------------|----------------------|---------------------|
| MAX4-PR36VX2 | 24 | 610 | 36 | 914 | 68 | 1702 |
| MAX4-PR48VX2 | 24 | 610 | 48 | 1219 | 68 | 1702 |

Two SS Drop-ins, One Tray Rack, One Bulk Shelf (4-tier)

| Model No. | Nominal Width (in.) | Nominal Width (mm) | Nominal Length (in.) | Nominal Length (mm) | Nominal Height (in.) | Nominal Height (mm) |
|--------------|---------------------|--------------------|----------------------|---------------------|----------------------|---------------------|
| MAX4-PR36VX3 | 24 | 610 | 36 | 914 | 68 | 1702 |
| MAX4-PR48VX3 | 24 | 610 | 48 | 1219 | 68 | 1702 |

Two Tray Racks and Two Pan Racks (4-tier)

| Model No. | Nominal Width (in.) | Nominal Width (mm) | Nominal Length (in.) | Nominal Length (mm) | Nominal Height (in.) | Nominal Height (mm) |
|--------------|---------------------|--------------------|----------------------|---------------------|----------------------|---------------------|
| MAX4-PR36VX4 | 24 | 610 | 36 | 914 | 68 | 1702 |
| MAX4-PR48VX4 | 24 | 610 | 48 | 1219 | 68 | 1702 |

Note: For the actual dimensions for mobile units, add 2" (51mm) to the nominal dimension to account for the bumpers.



MAX4-PR36VX2

Consists of (3) shelf frames, (4) 63" (1600mm) mobile posts, (4) corrosion resistant polymer casters (two swivel, two brake), (3) tray racks.



MAX4-PR36VX3

Consists of (3) shelf frames, (1) Bottom shelf with removable mats, (4) 63" (1600mm) mobile posts, (4) corrosion resistant polymer casters (two swivel, two brake), (1) tray rack, and (2) stainless steel drop-in racks.



MAX4-PR36VX4

Consists of (4) shelf frames, (4) 63" (1600mm) mobile posts, (4) corrosion resistant polymer casters (two swivel, two brake), (2) tray racks, and (2) pan racks.



Drying Rack Accessories

- Use to create a unique configuration to fit the application. These may be added to existing shelves or shelf frames when a specific configuration or single drying/ sorting tier is needed.

Cutting Board & Tray Drying Rack Accessories

- Mount to open grid and solid MetroMax i shelves, MetroMax i open shelf frames, MetroMax 4 open shelf frames, MetroMax Q, Super Erecta Pro, and Super Erecta.
- For best air circulation use with an open shelf frame.
- 1.12" (28mm) or 3" (76mm) slot spacing available.
- Polymer glide strips provide an impact resistant surface for long life.

| Model No. | Fits Shelf or Frame (mm) | | Upright Spacing (mm) | | Upright Height (mm) | | Tray Capacity | Approx. Pkd. Wt. (lbs./kg) | |
|-------------------|--------------------------|----------|----------------------|----|---------------------|-----|---------------|----------------------------|------|
| XTR2436XE | 24x36 | 610x914 | 1.12 | 28 | 6 | 150 | 24 | 14.7 | 6.7 |
| XTR2448XE | 24x48 | 610x1219 | 1.12 | 28 | 6 | 150 | 34 | 19.8 | 9.0 |
| XTR2460XE | 24x60 | 610x1524 | 1.12 | 28 | 6 | 150 | 43 | 25.4 | 11.5 |
| XTR2436XEA | 24x36 | 610x914 | 3 | 76 | 6 | 150 | 10 | 9.9 | 4.5 |
| XTR2448XEA | 24x48 | 610x1219 | 3 | 76 | 6 | 150 | 14 | 12.9 | 5.8 |
| XTR2460XEA | 24x60 | 610x1524 | 3 | 76 | 6 | 150 | 17 | 16.4 | 7.4 |

Note: Can be retrofitted to older Metro shelving systems.

Actual Width and Length: Add 7/8" (22mm) to nominal width. Add 1/2" (13mm) to nominal length.

Type 304 Stainless Drop-In Racks (for MetroMax i only)

- Drop-ins require a four-sided MetroMax i frame. See spec sheet 9.25
- Center beams are optional and may be added for additional load capacity.
- A drop-in rack can be added to a standard MetroMax i shelf by removing the shelf mats and using the shelf frame. The center beam is optional.

| Model No. | Fits Shelf or Frame (mm) | | Actual Length (mm) | | Actual Height (mm) | | Approx. Pkd. Wt. (lbs./kg) | |
|--------------|--------------------------|----------|--------------------|------|--------------------|-----|----------------------------|-----|
| DR36S | 24x36 | 610x914 | 33.87 | 860 | 5.25 | 133 | 6.5 | 2.9 |
| DR48S | 24x48 | 610x1219 | 45.87 | 1165 | 5.25 | 133 | 8.5 | 3.9 |
| DR60S | 24x60 | 610x1524 | 57.87 | 1470 | 5.25 | 133 | 11 | 5 |

Actual Width: Add 3/4" (19mm) to nominal width.

Drip Tray - Patent pending water collection system.

- Must be mounted to a **MetroMax i** shelf frame or shelf - Drip Tray assembly adjusts to fit 24x36" and 24x48" (610x914 or 610x1219mm) sizes.
- Consists of (2) solid polymer chutes and (1) mounting frame.
- Collection pan is not included. The mounting frame is designed to hold a full size steam pan or GN 1/1, preferably 2.5" or 4" tall (64 or 102mm).
- Materials
Solid Chute: HDPE
Mounting Frame: Aluminum
- Model No.: **XDRIP**

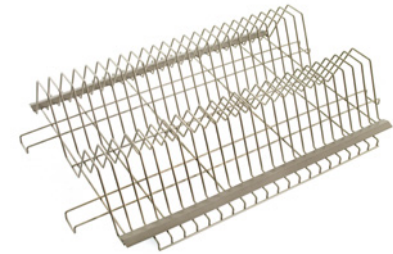

XTR2436XE

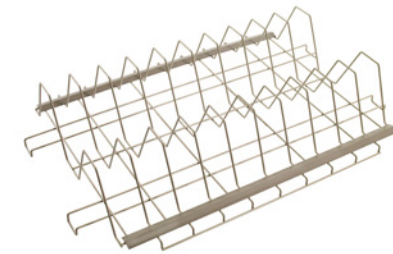

XTR2436XEA

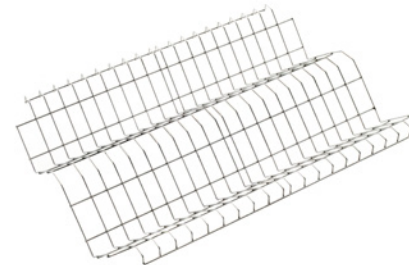

DR36S

Tip: Mount tray and pan racks on an open frame over the drip tray for maximum water collection.



Mounted to 24x48" (610x1219mm) Open Frame with Tray Rack. Steam Pan not included.

Sorting Pegs and Hanging Accessories

6" Tall (152mm) Sorting Pegs

- Installs to any open grid polymer Metro shelf
- Pack of 8 Pegs
- Can be used to manage steam pans 4" (102mm) and deeper
- Material: Mineral reinforced polypropylene
- Model No. **X6PEG-8PK**

X6PEG-8PK

X8



Drying Option.

Tray and pan drying wire racks are compatible with any Super Erecta, Super Erecta Pro, or Super Adjustable Super Erecta Shelf.



XTR2436XE Shown on a SmartWall unit atop of Super Erecta Shelving in Metroseal Gray.



XDRIP



Mounted to 24x36" (610x914mm) Frame. Steam Pan not included.

Superior materials and design for every application.



Super Erecta Pro®
 Super Adjustable Super Erecta®
 and Super Erecta®
 Erecta Shelf®
 HD Super™
 qwikSLOT®
 qwikSIGHT™

WIRE & SOLID SHELVING SOLUTIONS

Wire and Solid Shelving Solutions34-93
 Wire/Polymer Hybrid Shelving.....36-39
 Easy-Adjust Shelving & Carts.40-45
 Wire Shelving, Carts & Trucks.46-56
 Casters for Wire Shelving.....58-59
 Dollies & Plate Casters.....60-62
 Accessories for Wire Shelving.63-73
 Solid Shelving & Accessories74-76
 Light-Duty Wire Shelving & Accessories..... 77
 Heavy-Duty Solid Shelving & Accessories.....78-79
 qwikSLOT Adjustable Shelving80-83
 Basket Shelving & Accessories84-89
 Storage Bins & Totes90-93



LEARN MORE

**NEW
 FINISH**



SHELVING ASSEMBLY

Progress.



EASY TO CLEAN



LEARN MORE

Super Erecta Pro®
Durable & cleanable.
The original — reinnovated.

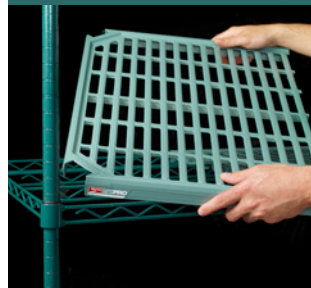

Easy to clean.

Lift-off mats can be easily removed and washed by hand or in a wash machine.

Prolonged durability.

Polymer shelf mats withstand daily abuse from containers and sharp edges. Robust design provides the strength and rigidity of Super Erecta...holds up to 800 lbs. (363kg) per shelf.



Interchangeable.

Super Erecta Pro shelves can be configured with traditional shelf and accessory options on the same unit for maximum flexibility.



Epoxy-coated Super Erecta-style frames with removable polymer shelf mats.

Stays cleaner between cleanings.

Polymer shelf mats and Metroseal Green epoxy-coated shelf frames and posts have built in Microban® antimicrobial product protection.



Super Erecta® Pro Shelves — {10.80}

Shelves are priced individually and packaged no more than 4 per carton except 60" (1524mm) and 72" (1829mm) lengths which are packaged no more than 2 per carton. Plastic split sleeves are included with each shelf.

| Nominal Width/Length (in.) | Nominal Width/Length (mm) | Cat. No. Super Erecta Pro Metroseal Green | Nominal Width/Length (in.) | Nominal Width/Length (mm) | Cat. No. Super Erecta Pro Metroseal Green |
|----------------------------|---------------------------|---|----------------------------|---------------------------|---|
| 14x24 | 355x610 | PR1424NK3 | 21x24 | 530x610 | PR2124NK3 |
| 14x30 | 355x760 | PR1430NK3 | 21x30 | 530x760 | PR2130NK3 |
| 14x36 | 355x914 | PR1436NK3 | 21x36 | 530x914 | PR2136NK3 |
| 14x42 | 355x1060 | PR1442NK3 | 21x42 | 530x1060 | PR2142NK3 |
| 14x48 | 355x1219 | PR1448NK3 | 21x48 | 530x1219 | PR2148NK3 |
| 14x54 | 530x1372 | - | 21x54 | 530x1372 | PR2154NK3 |
| 14x60 | 355x1524 | PR1460NK3 | 21x60 | 530x1524 | PR2160NK3 |
| 14x72 | 355x1829 | PR1472NK3 | 21x72 | 530x1829 | PR2172NK3 |
| 18x24 | 457x610 | PR1824NK3 | 24x24 | 610x610 | PR2424NK3 |
| 18x30 | 457x760 | PR1830NK3 | 24x30 | 610x760 | PR2430NK3 |
| 18x36 | 457x914 | PR1836NK3 | 24x36 | 610x914 | PR2436NK3 |
| 18x42 | 457x1060 | PR1842NK3 | 24x42 | 610x1060 | PR2442NK3 |
| 18x48 | 457x1219 | PR1848NK3 | 24x48 | 610x1219 | PR2448NK3 |
| 18x54 | 457x1372 | PR1854NK3 | 24x54 | 610x1372 | PR2454NK3 |
| 18x60 | 457x1524 | PR1860NK3 | 24x60 | 610x1524 | PR2460NK3 |
| 18x72 | 457x1829 | PR1872NK3 | 24x72 | 610x1829 | PR2472NK3 |

Note: Each Super Erecta Pro™ shelf up to and including 48" (1219mm) long have a maximum weight capacity of 800 lbs. (363kg) evenly distributed. Shelves longer than 48" (1219mm) have a maximum weight capacity of 600 lbs. (272kg) evenly distributed.
Actual Dimensions: Width: Add .25" (6mm) to nominal size. Length: Subtract .25" (6mm) from nominal size.



TRY NOW—IT'S SUPER EASY

SHELVING HEIGHT GUIDELINES

| Shelf Depth | 14" (356mm) | 18" (457mm) | 21" (533mm) | 24" (610mm) |
|-------------------------------|--------------|--------------|--------------|--------------|
| Maximum Allowable Post Height | 63" (1600mm) | 86" (2184mm) | 86" (2184mm) | 96" (2438mm) |

Note: For stationary units with foot plates or wall brackets properly attached to the floor or wall, the maximum allowable height is 96" (2438mm).

SiteSelect® Posts — {10.80}

Stationary Super Erecta SiteSelect posts are fitted with adjustable leveling bolts to compensate for uneven surfaces. Mobile posts come without leveling bolt assembly to accommodate stem casters. Special length posts are available. See page 58-59 for stem caster options.

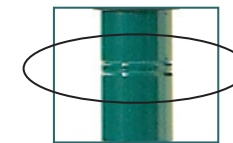

Posts provide a visual guide for positioning and adjusting shelves with an easy-to-identify double groove, every 8" (203mm).

Stationary Posts

| Height (in.) | Height (mm) | Cat. No. Metroseal 3 | Cat. No. Stainless |
|--------------|-------------|----------------------|--------------------|
| 14.37 | 370 | 13PK3 | 13PS |
| 34.37 | 875 | 33PK3 | 33PS |
| 54.44 | 1385 | 54PK3 | 54PS |
| 62.44 | 1590 | 63PK3 | 63PS |
| 74.5 | 1895 | 74PK3 | 74PS |
| 86.5 | 2200 | 86PK3 | 86PS |

Note: Height includes post cap and leveling bolt (Completely tightened).

Mobile Posts

| Height (in.) | Height (mm) | Cat. No. Metroseal 3 | Cat. No. Stainless |
|--------------|-------------|----------------------|--------------------|
| 13.75 | 349 | 13UPK3 | 13UPS |
| 33.75 | 857 | 33UPK3 | 33UPS |
| 53.81 | 1366 | 54UPK3 | 54UPS |
| 61.81 | 1570 | 63UPK3 | 63UPS |
| 69.75 | 1772 | 70UPK3 | — |
| 73.87 | 1876 | 74UPK3 | 74UPS |
| 85.87 | 2181 | 86UPK3 | 86UPS |

Super Erecta® Pro Easy Order Kits

Kit includes four shelves and four 74.5" (1892mm) split posts. Ships in one box.

| Nominal Width/Length (in.) (mm) | Approx. Pkd. Wt. (lbs.) (kg) | Cat. No. Super Erecta Pro Metroseal 3 |
|---------------------------------|------------------------------|---------------------------------------|
| 18x36 (457x914) | 58 26.3 | EZPR1836NK3-4 |
| 18x48 (457x1219) | 73 33.1 | EZPR1848NK3-4 |
| 24x36 (610x914) | 72 32.6 | EZPR2436NK3-4 |
| 24x48 (610x1219) | 83 37.6 | EZPR2448NK3-4 |





Shelving Starter and Add-On Units — {10.82}

- Starter Units consist of four posts and indicated number of Super Erecta Pro shelves.
- Add-On Units consist of two posts, indicated number of shelves, and two "S" Hooks per shelf, for attaching shelf to adjacent unit.

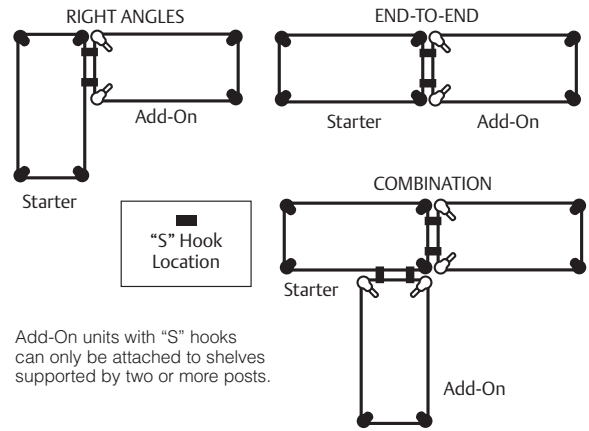

Add-On units with "S" hooks can only be attached to shelves supported by two or more posts.



4 Shelf Super Erecta Pro Unit with 63" Posts

4 Shelf Super Erecta Pro Unit with 74" Posts

| Nominal Width/Length (in.) (mm) | Cat. No. Starter Unit | Cat. No. Add-On Unit | Cat. No. Starter Unit | Cat. No. Add-On Unit |
|---------------------------------|-----------------------|----------------------|-----------------------|----------------------|
| 18x24 457x610 | PR-182463K3-S-4 | PR-182463K3-A-4 | PR-182474K3-S-4 | PR-182474K3-A-4 |
| 18x30 457x760 | PR-183063K3-S-4 | PR-183063K3-A-4 | PR-183074K3-S-4 | PR-183074K3-A-4 |
| 18x36 457x914 | PR-183663K3-S-4 | PR-183663K3-A-4 | PR-183674K3-S-4 | PR-183674K3-A-4 |
| 18x42 457x1060 | PR-184263K3-S-4 | PR-184263K3-A-4 | PR-184274K3-S-4 | PR-184274K3-A-4 |
| 18x48 457x1219 | PR-184863K3-S-4 | PR-184863K3-A-4 | PR-184874K3-S-4 | PR-184874K3-A-4 |
| 18x54 457x1372 | PR-185463K3-S-4 | PR-185463K3-A-4 | PR-185474K3-S-4 | PR-185474K3-A-4 |
| 18x60 457x1524 | PR-186063K3-S-4 | PR-186063K3-A-4 | PR-186074K3-S-4 | PR-186074K3-A-4 |
| 18x72 457x1829 | PR-187263K3-S-4 | PR-187263K3-A-4 | PR-187274K3-S-4 | PR-187274K3-A-4 |
| 21x24 530x610 | PR-212463K3-S-4 | PR-212463K3-A-4 | PR-212474K3-S-4 | PR-212474K3-A-4 |
| 21x30 530x760 | PR-213063K3-S-4 | PR-213063K3-A-4 | PR-213074K3-S-4 | PR-213074K3-A-4 |
| 21x36 530x914 | PR-213663K3-S-4 | PR-213663K3-A-4 | PR-213674K3-S-4 | PR-213674K3-A-4 |
| 21x42 530x1060 | PR-214263K3-S-4 | PR-214263K3-A-4 | PR-214274K3-S-4 | PR-214274K3-A-4 |
| 21x48 530x1219 | PR-214863K3-S-4 | PR-214863K3-A-4 | PR-214874K3-S-4 | PR-214874K3-A-4 |
| 21x54 530x1372 | PR-215463K3-S-4 | PR-215463K3-A-4 | PR-215474K3-S-4 | PR-215474K3-A-4 |
| 21x60 530x1524 | PR-216063K3-S-4 | PR-216063K3-A-4 | PR-216074K3-S-4 | PR-216074K3-A-4 |
| 21x72 530x1829 | PR-217263K3-S-4 | PR-217263K3-A-4 | PR-217274K3-S-4 | PR-217274K3-A-4 |
| 24x24 610x610 | PR-242463K3-S-4 | PR-242463K3-A-4 | PR-242474K3-S-4 | PR-242474K3-A-4 |
| 24x30 610x760 | PR-243063K3-S-4 | PR-243063K3-A-4 | PR-243074K3-S-4 | PR-243074K3-A-4 |
| 24x36 610x914 | PR-243663K3-S-4 | PR-243663K3-A-4 | PR-243674K3-S-4 | PR-243674K3-A-4 |
| 24x42 610x1060 | PR-244263K3-S-4 | PR-244263K3-A-4 | PR-244274K3-S-4 | PR-244274K3-A-4 |
| 24x48 610x1219 | PR-244863K3-S-4 | PR-244863K3-A-4 | PR-244874K3-S-4 | PR-244874K3-A-4 |
| 24x54 610x1372 | PR-245463K3-S-4 | PR-245463K3-A-4 | PR-245474K3-S-4 | PR-245474K3-A-4 |
| 24x60 610x1524 | PR-246063K3-S-4 | PR-246063K3-A-4 | PR-246074K3-S-4 | PR-246074K3-A-4 |
| 24x72 610x1829 | PR-247263K3-S-4 | PR-247263K3-A-4 | PR-247274K3-S-4 | PR-247274K3-A-4 |

For additional wire shelves, order from page 37.

Starter Unit



Add-On Unit



8x Add-On Units ship with (8) "S" Hooks



"S" Hooks

Eliminates the need for adjacent posts. Two required for each storage level. Cat. No. Q9995Z

Can be used to configure end-to-end and right angle (corner) add-on units.



Accessories — {10.81}

8" Polymer Divider

- Corrosion proof

| Nominal Length (in.) (mm) | Standard Duty Cat. No. | Light Duty Cat. No. |
|---------------------------|------------------------|---------------------|
| 18 457 | MQD18-8 | MUD18-8 |
| 24 610 | MQD24-8 | MUD24-8 |

Note: MUD18-8 Divider fits 21" deep shelf.



Standard Duty

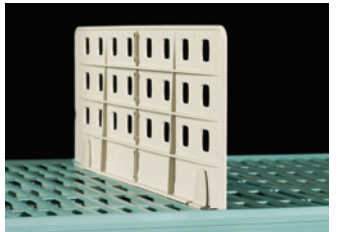

Light Duty

Tall Shelf-to-Shelf Divider

- Connects between two shelves
- Corrosion proof

| Nominal Height (in.) (mm) | Compatible with Shelf Depths (in.) (mm) | Cat. No. |
|---------------------------|---|----------|
| 16 406 | 18, 21 457, 530 | MD18-16 |
| 20 508 | 18, 21 457, 530 | MD18-20 |
| 24 610 | 18, 21 457, 530 | MD18-24 |
| 16 406 | 24 610 | MD24-16 |
| 20 508 | 24 610 | MD24-20 |
| 24 610 | 24 610 | MD24-24 |

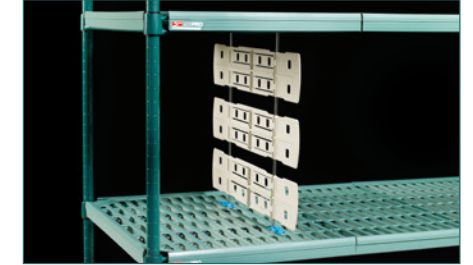

Shelf Ledges

- Corrosion proof, 2" (51mm) stackable shelf ledges.



| Nominal Length (in.) (mm) | Cat. No. |
|---------------------------|----------|
| 18 457 | PRL18-2S |
| 21 530 | PRL21-2S |
| 24 610 | PRL24-2S |
| 36 914 | PRL36-2S |
| 42 1060 | PRL42-2S |
| 48 1219 | PRL48-2S |
| 60 1524 | PRL60-2S |
| 72 1829 | PRL72-2S |

Color Shelf Marker

- 6" (152mm) Length
- Fits Super Erecta Pro Shelf
- Attach easily to shelf to identify contents stored.



| Color | Length (in.) (mm) | Cat. No. |
|--------|-------------------|----------|
| Blue | 6 152 | CSM6-BQ |
| Green | 6 152 | CSM6-GQ |
| Red | 6 152 | CSM6-RQ |
| Tan | 6 152 | CSM6-TQ |
| White | 6 152 | CSM6-WQ |
| Yellow | 6 152 | CSM6-YQ |
| Gray | 6 152 | CSM6-GRQ |



Label Holders

- Fits Super Erecta Pro Shelf
- Plastic holders snap into place to accommodate 1" (25mm) tall adhesive label.

Cat. No. MQ04LH



The easiest way to build Shelving.



Reclaim Wasted Space.



SHELVING ASSEMBLY



LEARN MORE

Super Adjustable Super Erecta® Shelving

Adjust and add shelves quickly and easily to reclaim wasted space.



Super Erecta

Easy “no-tool” shelf adjustment

1" (25mm) spacing minimizes dead space

Efficient use of space allows more storage levels to be added.

Storage efficiency can increase by 25% or more



Super Adjustable Super Erecta



Available Finishes

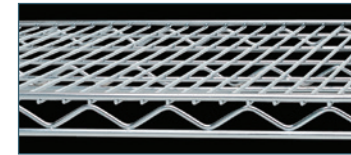

Type 304 Polished Stainless Steel
Addresses the most aggressive applications and environments. All-stainless solid and wire options exist for high temperature automated cart wash and autoclave applications.

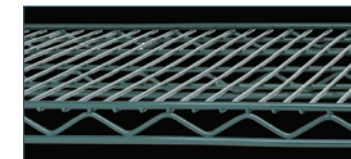

Metroseal Green Epoxy
Corrosion resistant finish for wet or high humidity environments with a 12 year warranty against rust and corrosion. Microban antimicrobial is built into the finish to keep the product “cleaner between cleanings.”

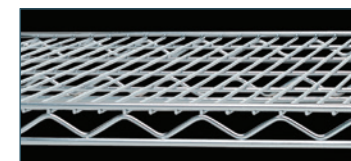

Chrome Plating
The “real” nickel-chrome finish for dry, low humidity environments. Metro’s durable chrome finish includes a protective lacquer coat.



Available Posts

Standard Stationary Post with adjustable leveling foot. Stainless models also feature a stainless leveling foot. Use Foot Plates for greater stability.

Standard Mobile-Ready Posts accept Metro stem casters. Use these for the majority of standard duty transport and movable storage applications.

Cart Wash and Autoclave Applications
Swaged stainless post has a fastened aluminum post cap and is specifically designed to withstand high temperatures. See page 59 for part numbers.

Heavy Duty Transport
Staked post attaches to a dolly truck to address abusive transport applications. The reinforced connection between the base receptacle and post provides a more secure connection to the dolly truck. See page 60 for part numbers.

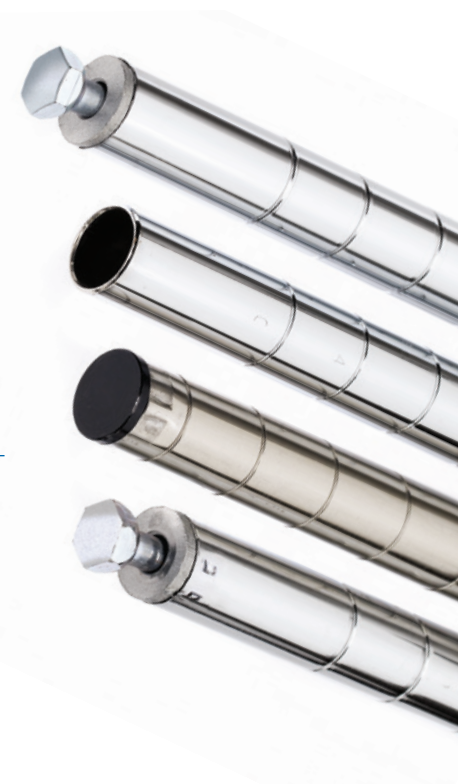

SUPER ADJUSTABLE SUPER ERECTA® SHELVING

Super Adjustable Super Erecta Wire Shelves — {10.01a} {10.10a}

Packaging: Wire shelves are priced individually and packaged no more than 4 per carton except 60" (1524mm) and 72" (1829mm) lengths and 30" (760mm) and 36" (914mm) widths, which are packaged no more than 2 per carton. Plastic sleeves and wedges are included with each shelf.

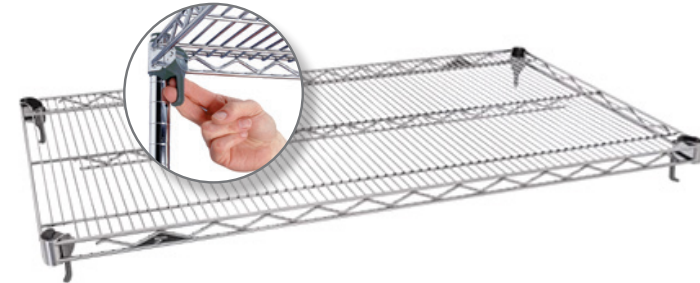

| Nominal Width/Length (in.) | Nominal Width/Length (mm) | Cat. No. Chrome | Cat. No. Metroseal Green | Cat. No. Stainless |
|----------------------------|---------------------------|-----------------|--------------------------|--------------------|
| 14x24 | 355x610 | A1424NC | A1424NK3 | A1424NS |
| 14x30 | 355x760 | A1430NC | A1430NK3 | A1430NS |
| 14x36 | 355x914 | A1436NC | A1436NK3 | A1436NS |
| 14x42 | 355x1060 | A1442NC | A1442NK3 | A1442NS |
| 14x48 | 355x1219 | A1448NC | A1448NK3 | A1448NS |
| 14x60 | 355x1524 | A1460NC | A1460NK3 | A1460NS |
| 14x72 | 355x1829 | A1472NC | A1472NK3 | A1472NS |
| 18x24 | 457x610 | A1824NC | A1824NK3 | A1824NS |
| 18x30 | 457x760 | A1830NC | A1830NK3 | A1830NS |
| 18x36 | 457x914 | A1836NC | A1836NK3 | A1836NS |
| 18x42 | 457x1060 | A1842NC | A1842NK3 | A1842NS |
| 18x48 | 457x1219 | A1848NC | A1848NK3 | A1848NS |
| 18x54 | 457x1370 | A1854NC | A1854NK3 | A1854NS |
| 18x60 | 457x1524 | A1860NC | A1860NK3 | A1860NS |
| 18x72 | 457x1829 | A1872NC | A1872NK3 | A1872NS |
| 21x24 | 530x610 | A2124NC | A2124NK3 | A2124NS |
| 21x30 | 530x760 | A2130NC | A2130NK3 | A2130NS |
| 21x36 | 530x914 | A2136NC | A2136NK3 | A2136NS |
| 21x42 | 530x1060 | A2142NC | A2142NK3 | A2142NS |
| 21x48 | 530x1219 | A2148NC | A2148NK3 | A2148NS |
| 21x54 | 530x1370 | A2154NC | A2154NK3 | A2154NS |
| 21x60 | 530x1524 | A2160NC | A2160NK3 | A2160NS |
| 21x72 | 530x1829 | A2172NC | A2172NK3 | A2172NS |
| 24x24 | 610x610 | A2424NC | A2424NK3 | A2424NS |
| 24x30 | 610x760 | A2430NC | A2430NK3 | A2430NS |
| 24x36 | 610x914 | A2436NC | A2436NK3 | A2436NS |
| 24x42 | 610x1060 | A2442NC | A2442NK3 | A2442NS |
| 24x48 | 610x1219 | A2448NC | A2448NK3 | A2448NS |
| 24x54 | 610x1370 | A2454NC | A2454NK3 | A2454NS |
| 24x60 | 610x1524 | A2460NC | A2460NK3 | A2460NS |
| 24x72 | 610x1829 | A2472NC | A2472NK3 | A2472NS |
| 30x36 | 760x914 | A3036NC | - | - |
| 30x48 | 760x1219 | A3048NC | - | - |
| 30x60 | 760x1524 | A3060NC | - | - |
| 30x72 | 760x1829 | A3072NC | - | - |
| 36x36 | 910x914 | A3636NC | - | - |
| 36x48 | 910x1219 | A3648NC | - | - |
| 36x60 | 910x1524 | A3660NC | - | - |
| 36x72 | 910x1829 | A3672NC | - | - |

Note: The actual length of the shelves is .12" (3.2mm) shorter than the nominal dimension shown. The actual depth of the shelves is .12" (3.2mm) greater than the nominal dimension shown. Wire shelves up to 48" (1219mm) long have a weight capacity of 800 lbs. (363kg); Shelves longer than 48" (1219mm) have a weight capacity of 600 lbs. (272kg) per shelf evenly distributed. 14" (355mm) deep shelving – Stationary units taller than 63" (1600mm) must be fastened to the floor or wall using Metro foot plates or wall brackets. On mobile units the maximum allowable post height is 54" (1370mm). Metroseal is not cart-washable.

The easiest way to build Shelving.

SiteSelect® Posts — {10.01a} {10.10a}

Stationary Super Erecta® SiteSelect posts are fitted with adjustable leveling bolts to compensate for uneven surfaces. Mobile posts come without leveling bolt assembly to accommodate stem casters. Special length posts are available.

Stationary Posts

| Actual Height (in.) | Actual Height (mm) | Cat. No. Chrome | Cat. No. Metroseal Green | Cat. No. Stainless |
|---------------------|--------------------|-----------------|--------------------------|--------------------|
| 7.37 | 191 | 7P | 7PK3 | 7PS |
| 14.37 | 370 | 13P | 13PK3 | 13PS |
| 28.37 | 699 | 27P | 27PK3 | 27PS |
| 34.37 | 875 | 33P | 33PK3 | 33PS |
| 54.44 | 1358 | 54P | 54PK3 | 54PS |
| 62.44 | 1590 | 63P | 63PK3 | 63PS |
| 74.5 | 1895 | 74P | 74PK3 | 74PS |
| 86.5 | 2200 | 86P | 86PK3 | 86PS |
| 96.5 | 2454 | ***96P | - | - |

*Height includes cap and leveling bolt (Completely tightened).
Stainless stationary post includes stainless leveling bolt.
***96P should not be used on units less than 24" (610mm) deep.
Consult Metro Engineering for alternate recommendations.

Note: Special length posts are available, priced at next higher length plus a cutting charge.

Mobile Posts

| Actual Height (in.) | Actual Height (mm) | Cat. No. Chrome | Cat. No. Metroseal Green | Cat. No. Stainless |
|---------------------|--------------------|-----------------|--------------------------|--------------------|
| 13.75 | 370 | 13UP | 13UPK3 | 13UPS |
| 27.75 | 699 | 27UP | 27UPK3 | 27UPS |
| 33.75 | 875 | 33UP | 33UPK3 | 33UPS |
| 54.81 | 1358 | 54UP | 54UPK3 | 54UPS |
| 61.81 | 1590 | 63UP | 63UPK3 | 63UPS |
| 69.75 | 1895 | - | 70UPK3 | - |
| 73.87 | 2200 | 74UP | 74UPK3 | 74UPS |
| 85.87 | 2454 | 86UP | 86UPK3 | 86UPS |

These posts come without leveling bolt assembly to accommodate stem casters. Casters for mobile applications can be found on pages 58 & 59.

Indicates antimicrobial product.



SUPER ADJUSTABLE SUPER ERECTA® SHELVING



Shelving Starter and Add-On Units — {10.91}

- Starter Units consist of four posts and indicated number of Super Adjustable Super Erecta shelves.
- Add-On Units consist of two posts, indicated number of shelves, and two "S" Hooks per shelf, for attaching shelf to adjacent unit.

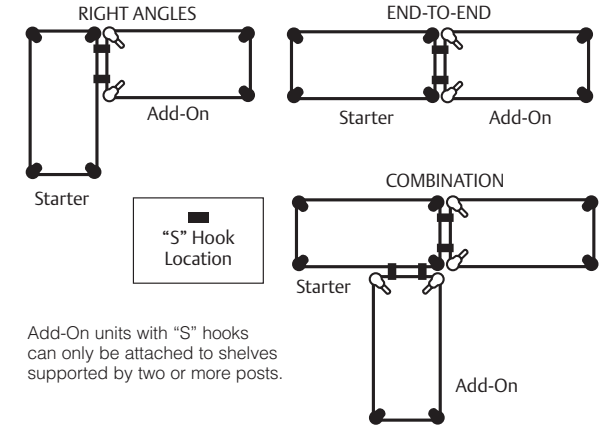

Add-On units with "S" hooks can only be attached to shelves supported by two or more posts.



| Nominal Width/Length (in.) | Nominal Width/Length (mm) | 4 Shelf Chrome Unit with 63" Posts | | 4 Shelf Chrome Unit with 74" Posts | | 5 Shelf Chrome Unit with 74" Posts | | 4 Shelf Metroseal Green Unit with 63" Posts | | 5 Shelf Metroseal Green Unit with 74" Posts | |
|----------------------------|---------------------------|------------------------------------|----------------------|------------------------------------|----------------------|------------------------------------|----------------------|---|----------------------|---|----------------------|
| | | Cat. No. Starter Unit | Cat. No. Add-On Unit | Cat. No. Starter Unit | Cat. No. Add-On Unit | Cat. No. Starter Unit | Cat. No. Add-On Unit | Cat. No. Starter Unit | Cat. No. Add-On Unit | Cat. No. Starter Unit | Cat. No. Add-On Unit |
| 18x24 | 457x610 | A316C | AA316C | - | - | 5A317C | 5AA317C | A316K3 | AA316K3 | 5A317K3 | 5AA317K3 |
| 18x30 | 457x760 | A326C | AA326C | - | - | 5A327C | 5AA327C | A326K3 | AA326K3 | 5A327K3 | 5AA327K3 |
| 18x36 | 457x914 | A336C | AA336C | SA-183674C-S-4 | - | 5A337C | 5AA337C | A336K3 | AA336K3 | 5A337K3 | 5AA337K3 |
| 18x42 | 457x1060 | A346C | AA346C | - | - | 5A347C | 5AA347C | A346K3 | AA346K3 | 5A347K3 | 5AA347K3 |
| 18x48 | 457x1219 | A356C | AA356C | SA-184874C-S-4 | - | 5A357C | 5AA357C | A356K3 | AA356K3 | 5A357K3 | 5AA357K3 |
| 18x60 | 457x1524 | A366C | AA366C | SA-186074C-S-4 | - | 5A367C | 5AA367C | A366K3 | AA366K3 | 5A367K3 | 5AA367K3 |
| 18x72 | 457x1829 | A376C | AA376C | SA-187274C-S-4 | - | 5A377C | 5AA377C | A376K3 | AA376K3 | 5A377K3 | 5AA377K3 |
| 21x24 | 530x610 | A416C | AA416C | - | - | 5A417C | 5AA417C | A416K3 | AA416K3 | 5A417K3 | 5AA417K3 |
| 21x30 | 530x760 | A426C | AA426C | - | - | 5A427C | 5AA427C | A426K3 | AA426K3 | 5A427K3 | 5AA427K3 |
| 21x36 | 530x914 | A436C | AA436C | - | - | 5A437C | 5AA437C | A436K3 | AA436K3 | 5A437K3 | 5AA437K3 |
| 21x42 | 530x1060 | A446C | AA446C | - | - | 5A447C | 5AA447C | A446K3 | AA446K3 | 5A447K3 | 5AA447K3 |
| 21x48 | 530x1219 | A456C | AA456C | - | - | 5A457C | 5AA457C | A456K3 | AA456K3 | 5A457K3 | 5AA457K3 |
| 21x60 | 530x1524 | A466C | AA466C | - | - | 5A467C | 5AA467C | A466K3 | AA466K3 | 5A467K3 | 5AA467K3 |
| 21x72 | 530x1829 | A476C | AA476C | - | - | 5A477C | 5AA477C | A476K3 | AA476K3 | 5A477K3 | 5AA477K3 |
| 24x24 | 610x610 | A516C | AA516C | - | - | 5A517C | 5AA517C | A516K3 | AA516K3 | 5A517K3 | 5AA517K3 |
| 24x30 | 610x760 | A526C | AA526C | - | - | 5A527C | 5AA527C | A526K3 | AA526K3 | 5A527K3 | 5AA527K3 |
| 24x36 | 610x914 | A536C | AA536C | SA-243674C-S-4 | - | 5A537C | 5AA537C | A536K3 | AA536K3 | 5A537K3 | 5AA537K3 |
| 24x42 | 610x1060 | A546C | AA546C | - | - | 5A547C | 5AA547C | A546K3 | AA546K3 | 5A547K3 | 5AA547K3 |
| 24x48 | 610x1219 | A556C | AA556C | SA-244874C-S-4 | - | 5A557C | 5AA557C | A556K3 | AA556K3 | 5A557K3 | 5AA557K3 |
| 24x60 | 610x1524 | A566C | AA566C | SA-246074C-S-4 | - | 5A567C | 5AA567C | A566K3 | AA566K3 | 5A567K3 | 5AA567K3 |
| 24x72 | 610x1829 | A576C | AA576C | SA-247274C-S-4 | - | 5A577C | 5AA577C | A576K3 | AA576K3 | 5A577K3 | 5AA577K3 |

For Super Adjustable Super Erecta, order from page 42.

Indicates antimicrobial product.



Replacement "S" Hook

2 are required for each storage level.
Cat. No. 9995Z



Security "S" Hook

2 are required for each storage level.
Chrome. Cat. No. H9995C
Black. Cat. No. H9995B



Super Adjustable Super Erecta® Stem Caster Carts — {11.01a}

5" (127mm) resilient rubber or polyurethane casters with donut bumpers.

Safely Hold up to **600lbs.** per mobile unit.
 BC models with resilient rubber casters.

Safely Hold up to **900lbs.** per mobile unit.
 EC models with polyurethane casters.



COMPLETE UNIT HEIGHT
67 7/8" (1724mm)

4-Shelf Mobile Chrome Unit with 63" Posts

| Nominal Width/Length (in.) (mm) | Resilient Rubber Casters (2) Swivel, (2) Brake | Polyurethane Casters (2) Swivel, (2) Brake |
|---------------------------------|--|--|
| 18x36 457x914 | A336BC | A336EC |
| 18x48 457x1219 | A356BC | A356EC |
| 18x60 457x1524 | A366BC | A366EC |
| 21x36 530x914 | A436BC | A436EC |
| 21x48 530x1219 | A456BC | A456EC |
| 21x60 530x1524 | A466BC | A466EC |
| 24x36 610x914 | A536BC | A536EC |
| 24x48 610x1219 | A556BC | A556EC |
| 24x60 610x1524 | A566BC | A566EC |

5-Shelf Mobile Chrome Unit with 63" Posts

| Resilient Rubber Casters (2) Swivel, (2) Brake | Polyurethane Casters (2) Swivel, (2) Brake |
|--|--|
| 5A336BC | 5A336EC |
| 5A356BC | 5A356EC |
| 5A366BC | 5A366EC |
| 5A436BC | 5A436EC |
| 5A456BC | 5A456EC |
| 5A466BC | 5A466EC |
| 5A536BC | 5A536EC |
| 5A556BC | 5A556EC |
| 5A566BC | 5A566EC |

COMPLETE UNIT HEIGHT
80" (2032mm)

4-Shelf Mobile Chrome Unit with 74" Posts

| Nominal Width/Length (in.) (mm) | Polyurethane Casters (2) Swivel, (2) Brake |
|---------------------------------|--|
| 18x36 457x914 | SA-183680C-MU-4 |
| 18x48 457x1219 | SA-184880C-MU-4 |
| 18x60 457x1524 | SA-186080C-MU-4 |
| 18x72 457x1829 | SA-187280C-MU-4 |
| 24x36 610x914 | SA-243680C-MU-4 |
| 24x48 610x1219 | SA-244880C-MU-4 |
| 24x60 610x1524 | SA-246080C-MU-4 |
| 24x72 610x1829 | SA-247280C-MU-4 |

For Super Adjustable Super Erecta, order from page 42.



The easiest way to build Shelving.



Standard Wire Cart
ECN56CA

Perfect for:
Healthcare Par Level



Deluxe Wire Cart
ECM56CD



Deluxe Dolly Truck
ECN56CC

Super Adjustable Super Erecta® Wire Carts

Patented release lever to allows for easy reconfiguration of shelves as supply dimensions change. Optional dividers, ledges, enclosure panels, Super Erecta® Slides and tote boxes in various combinations, can be added, removed or reconfigured to adapt to change. Also available in stainless steel. Cart covers are available.

Standard Wire Cart

Includes four chrome-plated adjustable wire shelves, one solid bottom shelf, chrome-plated posts, 5" (127mm) high-modulus donut stem casters (two with brakes), and six label holders.

| Shelf Width/Length (in.) (mm) | Overall Height (in.) (mm) | Cat. No. with Galvanized Bottom Shelf | Cat. No. with Stainless Bottom Shelf |
|-------------------------------|---------------------------|---------------------------------------|--------------------------------------|
| 21x48 530x1219 | 67.87 1724 | ECN45CA | ECM45XA |
| 21x60 530x1524 | 67.87 1724 | ECN46CA | ECM46XA |
| 24x48 610x1219 | 67.87 1724 | ECN55CA | ECM55XA |
| 24x60 610x1524 | 67.87 1724 | ECN56CA | ECM56XA |

Wire Cart

Includes four chrome-plated adjustable wire shelves, one solid bottom shelf, chrome-plated posts, 5" (127mm) high-modulus donut stem casters (two with brakes), side and back enclosure panels, one or two Super Slides, two or four 6" (152mm) deep tote boxes with box dividers, four or six shelf dividers and twelve label holders.

| Shelf Width/Length (in.) (mm) | Overall Height (in.) (mm) | Tote Boxes 6" (152mm) Deep | Shelf Dividers | Super Slides | Cat. No. with Galvanized Bottom Shelf | Cat. No. with Stainless Bottom Shelf |
|-------------------------------|---------------------------|----------------------------|----------------|--------------|---------------------------------------|--------------------------------------|
| 24x48 610x1219 | 67.87 1724 | 2 | 4 | 1 | ECN55CD | ECM55XD |
| 24x60 610x1524 | 67.87 1724 | 4 | 6 | 2 | ECN56CD | ECM56XD |

Standard Dolly Truck

Includes four chrome-plated adjustable wire shelves, one solid bottom shelf, chrome-plated posts, aluminum dolly frame with wraparound bumper, 8" (203mm) resilient casters (two with swivel locks), and six label holders.

| Shelf Width/Length (in.) (mm) | Overall Height (in.) (mm) | Cat. No. with Galvanized Bottom Shelf | Cat. No. with Stainless Bottom Shelf |
|-------------------------------|---------------------------|---------------------------------------|--------------------------------------|
| 21x48 530x1219 | 71.69 1821 | ECN45CS | ECM45XS |
| 21x60 530x1524 | 71.69 1821 | ECN46CS | ECM46XS |
| 24x48 610x1219 | 71.69 1821 | ECN55CS | ECM55XS |
| 24x60 610x1524 | 71.69 1821 | ECN56CS | ECM56XS |

Deluxe Dolly Truck

Includes four chrome-plated adjustable wire shelves, one solid bottom shelf, chrome-plated posts, aluminum dolly frame with wraparound bumper, 8" (203mm) resilient casters (two with swivel locks), side and back enclosure panels, one or two Super Slides, two or four 6" (152mm) deep tote boxes with box dividers, four or six shelf dividers and twelve label holders. Overall height: 71.69 (1821mm).

| Shelf Width/Length (in.) (mm) | Tote Boxes 6" (152mm) Deep | Shelf Dividers | Super Slides | Cat. No. with Galvanized Bottom Shelf | Cat. No. with Stainless Bottom Shelf |
|-------------------------------|----------------------------|----------------|--------------|---------------------------------------|--------------------------------------|
| 24x48 610x1219 | 2 | 4 | 1 | ECN55CC | ECM55XC |
| 24x60 610x1524 | 4 | 6 | 2 | ECN56CC | ECM56XC |



Genuine Metro



LEARN MORE



SB
Shelf Builder

The easiest way to build Shelving.



SHELVING ASSEMBLY

Super Erecta® Shelving System The original wire storage system.

A storage system that defines the extent of space, Super Erecta's revolutionary concept was fresh and innovative from its start — nearly 50 years ago. It has continued to evolve, with nearly 100 highly specialized accessories, aimed at meeting the diversity of today's challenges.

- Adjustable: Shelves can be set and repositioned at precise 1" (25mm) increments along the length of the numbered posts.
- Unique Design: Open-wire design minimizes dust accumulation, allows a free circulation of air, and greater visibility of stored items.
- Mobile: Full choice of caster types available for mobile applications.

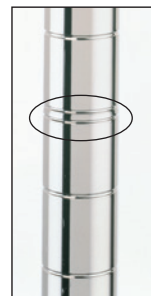

SiteSelect posts provide a visual guide for positioning and adjusting shelves, saving considerable time during assembly and adjustment. An easy-to-identify double groove, every 8" (203mm), offers a quick way to align all shelves.

Available Finishes



Type 304 Polished Stainless Steel
Addresses the most aggressive applications and environments. All-stainless solid and wire options exist for high temperature automated cart wash and autoclave applications.

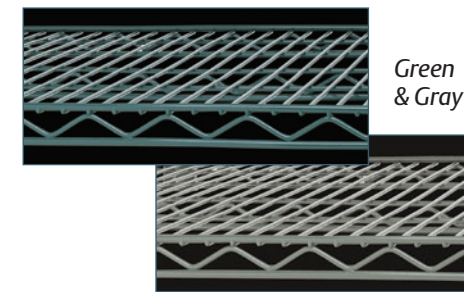

Metroseal™ Epoxy
Corrosion resistant finish for wet or high humidity environments with a 12-year warranty against rust and corrosion. Microban antimicrobial is built into the finish to keep the product "cleaner between cleanings."

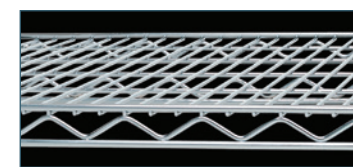

Chrome Plating
Nickel-chrome finish for dry, low humidity environments. Metro's durable chrome finish includes a protective lacquer coat.

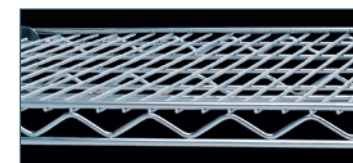

Brite
Economical, chromate finish for dry, low humidity environments. Metro's Brite finish provides the look of chrome and includes a protective lacquer coat.



Standard Epoxy and Designer Finishes

A pleasing aesthetic and basic protection for dry environments.



Available Posts

Standard Stationary Post with adjustable leveling foot. Stainless models also feature a stainless leveling foot. Use Foot Plates for greater stability.

Standard Mobile-Ready Posts accept Metro stem casters. Use these for the majority of standard duty transport and movable storage applications.

Cart Wash and Autoclave Applications
Swaged stainless post has a fastened aluminum post cap and is specifically designed to withstand high temperatures. See page 59 for part numbers.

Heavy Duty Transport
Staked post attaches to a dolly truck to address abusive transport applications. The reinforced connection between the base receptacle and post provides a more secure connection to the dolly truck. See page 60 for part numbers.





Wire Shelves — {10.01a} {10.10a}

Weight capacity is 800 lbs. (363kg) per shelf for lengths of 18" to 48" (457 to 1219mm) 600 lbs. (272kg) for lengths of 54" (1370mm) or longer. Stationary units have a maximum capacity of 2,000 lbs. (907kg). Mobile units have a maximum capacity of three times the caster load rating up to but not exceeding 1,000 lbs. (453kg) total.

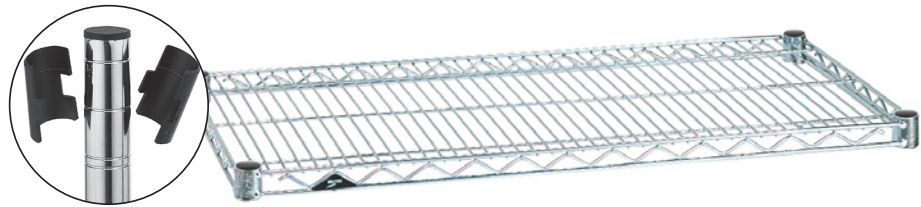

The easiest way to build Shelving.

| Nominal Width/Length (in.) (mm) | Cat. No. Super Erecta Brite | Cat. No. Chrome | Cat. No. Metroseal Green (K3) with Microban | Cat. No. Metroseal Gray (K4) with Microban | Cat. No. Stainless |
|------------------------------------|--------------------------------|--------------------|---|--|-----------------------|
| 14x24 | 1424BR | 1424NC | 1424NK3 | 1424NK4 | 1424NS |
| 14x30 | 1430BR | 1430NC | 1430NK3 | 1430NK4 | 1430NS |
| 14x36 | 1436BR | 1436NC | 1436NK3 | 1436NK4 | 1436NS |
| 14x42 | 1442BR | 1442NC | 1442NK3 | 1442NK4 | 1442NS |
| 14x48 | 1448BR | 1448NC | 1448NK3 | 1448NK4 | 1448NS |
| 14x60 | 1460BR | 1460NC | 1460NK3 | 1460NK4 | 1460NS |
| 14x72 | 1472BR | 1472NC | 1472NK3 | 1472NK4 | 1472NS |
| 18x18 | - | 1818NC | 1818NK3 | 1818NK4 | - |
| 18x24 | 1824BR | 1824NC | 1824NK3 | 1824NK4 | 1824NS |
| 18x30 | 1830BR | 1830NC | 1830NK3 | 1830NK4 | 1830NS |
| 18x36 | 1836BR | 1836NC | 1836NK3 | 1836NK4 | 1836NS |
| 18x42 | 1842BR | 1842NC | 1842NK3 | 1842NK4 | 1842NS |
| 18x48 | 1848BR | 1848NC | 1848NK3 | 1848NK4 | 1848NS |
| 18x54 | 1854BR | 1854NC | 1854NK3 | 1854NK4 | 1854NS |
| 18x60 | 1860BR | 1860NC | 1860NK3 | 1860NK4 | 1860NS |
| 18x72 | 1872BR | 1872NC | 1872NK3 | 1872NK4 | 1872NS |
| 21x24 | 2124BR | 2124NC | 2124NK3 | 2124NK4 | 2124NS |
| 21x30 | 2130BR | 2130NC | 2130NK3 | 2130NK4 | 2130NS |
| 21x36 | 2136BR | 2136NC | 2136NK3 | 2136NK4 | 2136NS |
| 21x42 | 2142BR | 2142NC | 2142NK3 | 2142NK4 | 2142NS |
| 21x48 | 2148BR | 2148NC | 2148NK3 | 2148NK4 | 2148NS |
| 21x54 | 2154BR | 2154NC | 2154NK3 | 2154NK4 | 2154NS |
| 21x60 | 2160BR | 2160NC | 2160NK3 | 2160NK4 | 2160NS |
| 21x72 | 2172BR | 2172NC | 2172NK3 | 2172NK4 | 2172NS |
| 24x24 | 2424BR | 2424NC | 2424NK3 | 2424NK4 | 2424NS |
| 24x30 | 2430BR | 2430NC | 2430NK3 | 2430NK4 | 2430NS |
| 24x36 | 2436BR | 2436NC | 2436NK3 | 2436NK4 | 2436NS |
| 24x42 | 2442BR | 2442NC | 2442NK3 | 2442NK4 | 2442NS |
| 24x48 | 2448BR | 2448NC | 2448NK3 | 2448NK4 | 2448NS |
| 24x54 | 2454BR | 2454NC | 2454NK3 | 2454NK4 | 2454NS |
| 24x60 | 2460BR | 2460NC | 2460NK3 | 2460NK4 | 2460NS |
| 24x72 | 2472BR | 2472NC | 2472NK3 | 2472NK4 | 2472NS |

Note: The actual length of the shelves is .12" (3.2mm) shorter than the nominal dimension shown. The actual depth of the shelves is .12" (3.2mm) greater than the nominal dimension shown.

| SHELVING HEIGHT GUIDELINES | | | | | | |
|--------------------------------------|--------------|--------------|--------------|--------------|--------------|--------------|
| Shelf Depth | 14" (356mm) | 18" (457mm) | 21" (533mm) | 24" (610mm) | 30" (762mm) | 36" (914mm) |
| Maximum Allowable Post Height | ▼ ▼ ▼ ▼ ▼ ▼ | | | | | |
| Stationary | 63" (1600mm) | 86" (2184mm) | 86" (2184mm) | 96" (2438mm) | 96" (2438mm) | 96" (2438mm) |
| Mobile | 54" (1372mm) | 74" (1880mm) | 74" (1880mm) | 86" (2184mm) | 86" (2184mm) | 86" (2184mm) |

Note: For stationary units with foot plates or wall brackets properly attached to the floor or wall, the maximum allowable height is 96" (2438mm).



Super Wide Shelving — {10.01a} {10.10a}

30" & 36" wide shelves are best for large quantities of supplies or large, bulky objects.

| Cat. No. Chrome | Cat. No. Metroseal Green | Cat. No. Metroseal Gray | Cat. No. Stainless Steel | Width/Length (in.) (mm) | Pkd. Wt. (lbs.) (kg) |
|--------------------|-----------------------------|----------------------------|-----------------------------|----------------------------|-------------------------|
| 3036NC | 3036NK3 | 3036NK4 | 3036NS | 30x36 760x914 | 14.2 6.4 |
| 3048NC | 3048NK3 | 3048NK4 | 3048NS | 30x48 760x1219 | 17.7 8.0 |
| 3060NC | 3060NK3 | 3060NK4 | 3060NS | 30x60 760x1524 | 20.2 9.2 |
| 3072NC | 3072NK3 | 3072NK4 | 3072NS | 30x72 760x1829 | 22.7 10.3 |
| 3636NC | 3636NK3 | - | 3636NS | 36x36 910x914 | 16.7 7.6 |
| 3648NC | 3648NK3 | - | 3648NS | 36x48 910x1219 | 21.6 9.8 |
| 3660NC | 3660NK3 | - | 3660NS | 36x60 910x1524 | 26.4 12.0 |
| 3672NC | 3672NK3 | - | 3672NS | 36x72 910x1829 | 31.6 14.3 |

Load Capacity Per Shelf 800 lbs. (363kg) for lengths 48" (1219mm) or shorter. 600 lbs. (272kg) for lengths 54" (1370mm) or longer.



SiteSelect® Posts — {10.01a} {10.10a}

Stationary Super Erecta® SiteSelect posts are fitted with adjustable leveling bolts. Mobile posts come without leveling bolt assembly to accommodate stem casters.

Stationary Posts

| Cat. No. Chrome | Cat. No. Metroseal Green (K3) with Microban | Cat. No. Metroseal Gray (K4) with Microban | Cat. No. Stainless Steel | Actual Height (in.) (mm) | Approx Pkd. Wt. (lbs.) (kg) |
|--------------------|---|--|-----------------------------|-----------------------------|--------------------------------|
| 7P | 7PK3 | 7PK4 | - | 7.4 187 | 0.5 0.3 |
| 13P | 13PK3 | 13PK4 | 13PS | 14.4 365 | 1 0.5 |
| 27P | 27PK3 | 27PK4 | 27PS | 28.4 720 | 1.75 0.75 |
| 33P | 33PK3 | 33PK4 | 33PS | 34.4 873 | 2 0.9 |
| 54P | 54PK3 | 54PK4 | 54PS | 54.4 1382 | 3 1.4 |
| 63P | 63PK3 | 63PK4 | 63PS | 62.4 1585 | 3.5 1.6 |
| 74P | 74PK3 | 74PK4 | 74PS | 74.5 1892 | 4 1.8 |
| 86P | 86PK3 | 86PK4 | 86PS | 86.5 2197 | 5 2.3 |
| *96P | - | - | - | 96.5 2450 | 5.5 2.5 |

*96P should not be used on units less than 24" (610mm) deep. Consult Metro Engineering for alternate recommendations.

Mobile Posts (For use with Stem Casters)

| Cat. No. Chrome | Cat. No. Metroseal Green (K3) with Microban | Cat. No. Metroseal Gray (K4) with Microban | Cat. No. Stainless Steel | Actual Height (in.) (mm) | Approx. Pkd. Wt. (lbs.) (kg) |
|--------------------|---|--|-----------------------------|-----------------------------|---------------------------------|
| 13UP | 13UPK3 | 13UPK4 | 13UPS | 13.75 349 | 1 0.5 |
| 27UP | 27UPK3 | 27UPK4 | 27UPS | 27.75 704 | 1.75 0.75 |
| 33UP | 33UPK3 | 33UPK4 | 33UPS | 33.75 857 | 2 0.9 |
| 54UP | 54UPK3 | 54UPK4 | 54UPS | 53.8 1366 | 3 1.4 |
| 63UP | 63UPK3 | 63UPK4 | 63UPS | 61.8 1570 | 3.5 1.6 |
| - | 70UPK3 | 70UPK4 | - | 69.75 1771 | 3.75 1.7 |
| 74UP | 74UPK3 | 74UPK4 | 74UPS | 73.9 1876 | 4 1.8 |
| 86UP | 86UPK3 | 86UPK4 | 86UPS | 85.9 2181 | 4.5 2.0 |

Staked Posts (For use with Truck Dollies)

Each post connects to the truck dolly through the stem receptacle. The stem receptacle is staked into the bottom of the post for abusive mobile applications. Each includes a leveling/connecting bolt.

| Cat. No. Chrome | Cat. No. Stainless Steel | Height (in.) (mm) | Pkd. Wt. (lbs.) (kg) |
|--------------------|-----------------------------|----------------------|-------------------------|
| 54P-STKD | 54PS-STKD | 54.4 1382 | 3 1.4 |
| 63P-STKD | 63PS-STKD | 62.4 1585 | 3.5 1.6 |
| 74P-STKD | 74PS-STKD | 74.5 1892 | 4 1.8 |

Swaged Posts (For use with Stem Casters in Cart Wash Applications)

Each post has an aluminum cap swaged into the top of the post.

| Cat. No. Stainless Steel | Height (in.) (mm) | Pkd. Wt. (lbs.) (kg) |
|-----------------------------|----------------------|-------------------------|
| 33UPS-SW | 33.75 857 | 2 .9 |
| 54UPS-SW | 53.8 1366 | 3 1.4 |
| 63UPS-SW | 61.8 1570 | 3.5 1.6 |



SiteSelect Posts feature double grooves every 8" (203mm) to aid assembly.



Stationary Post



Post for Stem Caster



Staked Post



Swaged Post

Special Length Posts

Cut posts are available. Consult your Metro representative for more information.



Designer Color Shelving — {10.14}

| Width/Length (mm) | | Pkd. Wt. (lbs.) | Pkd. Wt. (kg) | Cat. No. | | Cat. No. | |
|-------------------|----------|-----------------|---------------|----------|--------|--------------|--------------------|
| (in.) | (mm) | | | Black | White | Smoked Glass | Copper Hammettone† |
| 14x24 | 355x610 | 6 | 2.7 | 1424NBL | 1424NW | 1424N-DSG | 1424N-DCH |
| 14x30 | 355x760 | 7 | 3.2 | 1430NBL | 1430NW | 1430N-DSG | 1430N-DCH |
| 14x36 | 355x914 | 8 | 3.6 | 1436NBL | 1436NW | 1436N-DSG | 1436N-DCH |
| 14x42 | 355x1066 | 9.5 | 4.3 | 1442NBL | 1442NW | 1442N-DSG | 1442N-DCH |
| 14x48 | 355x1219 | 10.5 | 4.7 | 1448NBL | 1448NW | 1448N-DSG | 1448N-DCH |
| 14x60 | 355x1524 | 14 | 6.3 | 1460NBL | 1460NW | 1460N-DSG | 1460N-DCH |
| 14x72 | 355x1829 | 17 | 7.7 | 1472NBL | 1472NW | 1472N-DSG | 1472N-DCH |
| 18x18 | 457x457 | 6 | 2.7 | 1818NBL | 1818NW | 1818N-DSG | 1818N-DCH |
| 18x24 | 457x610 | 7 | 3.2 | 1824NBL | 1824NW | 1824N-DSG | 1824N-DCH |
| 18x30 | 457x760 | 8 | 3.6 | 1830NBL | 1830NW | 1830N-DSG | 1830N-DCH |
| 18x36 | 457x914 | 9.5 | 4.3 | 1836NBL | 1836NW | 1836N-DSG | 1836N-DCH |
| 18x42 | 457x1066 | 11 | 5.0 | 1842NBL | 1842NW | 1842N-DSG | 1842N-DCH |
| 18x48 | 457x1219 | 12 | 5.4 | 1848NBL | 1848NW | 1848N-DSG | 1848N-DCH |
| 18x54 | 457x1370 | 14.5 | 6.6 | 1854NBL | 1854NW | 1854N-DSG | 1854N-DCH |
| 18x60 | 457x1524 | 17 | 7.7 | 1860NBL | 1860NW | 1860N-DSG | 1860N-DCH |
| 18x72 | 457x1829 | 20 | 9.1 | 1872NBL | 1872NW | 1872N-DSG | 1872N-DCH |
| 21x24 | 530x610 | 8 | 3.6 | 2124NBL | 2124NW | 2124N-DSG | 2124N-DCH |
| 21x30 | 530x760 | 9 | 4.1 | 2130NBL | 2130NW | 2130N-DSG | 2130N-DCH |
| 21x36 | 530x914 | 11 | 5.0 | 2136NBL | 2136NW | 2136N-DSG | 2136N-DCH |
| 21x42 | 530x1066 | 12 | 5.4 | 2142NBL | 2142NW | 2142N-DSG | 2142N-DCH |
| 21x48 | 530x1219 | 14 | 6.4 | 2148NBL | 2148NW | 2148N-DSG | 2148N-DCH |
| 21x54 | 530x1370 | 16 | 7.3 | 2154NBL | 2154NW | 2154N-DSG | 2154N-DCH |
| 21x60 | 530x1524 | 18 | 8.2 | 2160NBL | 2160NW | 2160N-DSG | 2160N-DCH |
| 21x72 | 530x1829 | 24 | 10.9 | 2172NBL | 2172NW | 2172N-DSG | 2172N-DCH |
| 24x24 | 610x610 | 9 | 4.1 | 2424NBL | 2424NW | 2424N-DSG | 2424N-DCH |
| 24x30 | 610x760 | 11 | 5.0 | 2430NBL | 2430NW | 2430N-DSG | 2430N-DCH |
| 24x36 | 610x914 | 13 | 5.9 | 2436NBL | 2436NW | 2436N-DSG | 2436N-DCH |
| 24x42 | 610x1066 | 15 | 6.8 | 2442NBL | 2442NW | 2442N-DSG | 2442N-DCH |
| 24x48 | 610x1219 | 16 | 7.3 | 2448NBL | 2448NW | 2448N-DSG | 2448N-DCH |
| 24x54 | 610x1370 | 19 | 8.6 | 2454NBL | 2454NW | 2454N-DSG | 2454N-DCH |
| 24x60 | 610x1524 | 21 | 9.5 | 2460NBL | 2460NW | 2460N-DSG | 2460N-DCH |
| 24x72 | 610x1829 | 26 | 11.8 | 2472NBL | 2472NW | 2472N-DSG | 2472N-DCH |

Note: White epoxy Super Erecta shelves come with white split sleeves.
 Note: All Black, Smoked Glass and Designer Super Erecta shelves come with black split sleeves.
 Note: Black shelving is NSF listed. White, Smoked Glass, and Designer Colors are not NSF listed.



Posts — {10.14}

| Height* (in.) | | Pkd. Wt. (lbs.) | Pkd. Wt. (kg) | Cat. No. | | Cat. No. | |
|---------------|------|-----------------|---------------|----------|-------|--------------|-------------------|
| (mm) | (mm) | | | Black | White | Smoked Glass | Copper Hammettone |
| 7.4 | 191 | 0.5 | 0.3 | 7PBL | 7PW | 7P-DSG | 7P-DCH |
| 14.4 | 370 | 1 | 0.5 | 13PBL | 13PW | 13P-DSG | 13P-DCH |
| 28.4 | 699 | 1.75 | .75 | 27PBL | 27PW | 27P-DSG | 27P-DCH |
| 34.4 | 875 | 2 | 0.9 | 33PBL | 33PW | 33P-DSG | 33P-DCH |
| 54.4 | 1385 | 3 | 1.4 | 54PBL | 54PW | 54P-DSG | 54P-DCH |
| 62.4 | 1590 | 3.5 | 1.6 | 63PBL | 63PW | 63P-DSG | 63P-DCH |
| 74.5 | 1895 | 4 | 1.8 | 74PBL | 74PW | 74P-DSG | 74P-DCH |
| 86.5 | 2200 | 5 | 2.3 | 86PBL | 86PW | 86P-DSG | 86P-DCH |

| Height* (in.) | | Pkd. Wt. (lbs.) | Pkd. Wt. (kg) | Cat. No. | | Cat. No. | |
|---------------|------|-----------------|---------------|----------|----------|--------------|-------------------|
| (mm) | (mm) | | | Black | White | Smoked Glass | Copper Hammettone |
| — | — | — | — | — | — | — | — |
| 27.75 | 699 | 27UPBL | 27UPW | 27UP-DSG | 27UP-DCH | — | — |
| 33.75 | 875 | 33UPBL | 33UPW | 33UP-DSG | 33UP-DCH | — | — |
| 53.8 | 1358 | 54UPBL | 54UPW | 54UP-DSG | 54UP-DCH | — | — |
| 61.8 | 1590 | 63UPBL | 63UPW | 63UP-DSG | 63UP-DCH | — | — |
| 73.9 | 2200 | 74UPBL | 74UPW | 74UP-DSG | 74UP-DCH | — | — |
| 85.9 | 2454 | 86UPBL | 86UPW | 86UP-DSG | 86UP-DCH | — | — |

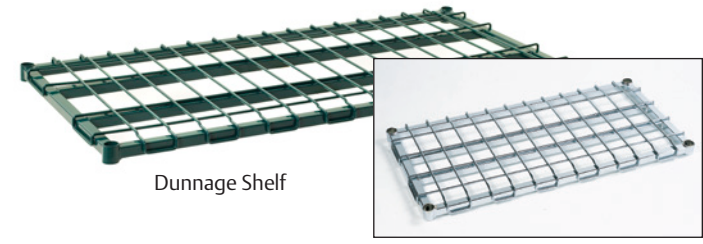

Heavy-Duty Dunnage Shelves — {10.45}

Enhance the weight-bearing capacity. 36" (914mm) shelf holds 1,600 pounds (725kg) (uniformly distributed); 48" (1219mm) shelves carry up to 1,300 pounds (590kg); 60" (1524mm) shelves bear up to 1,000 pounds (453kg).
 • Removable wire mat: Lifts off for easy cleaning. .31" (7.9mm) diameter wire. Support frames: 1" (25mm) square tubing.

Cantilever Shelves — {10.05}

Adds convenient space above a storage unit. Drop mat design creates a retaining ledge around the entire 12" (305mm) deep shelf. Remember to order rear posts taller than front posts to accommodate these shelves.

| Length (in.) | | Pkd. Wt. Each (lbs.) | Pkd. Wt. Each (kg) | Cat. No. | | Cat. No. | | Cat. No. | |
|--------------|------|----------------------|--------------------|----------|-----------|----------|--------------|----------|---|
| (mm) | (mm) | | | Chrome | Black | White | Smoked Glass | | |
| 24 | 610 | 4.5 | 2.0 | 1224CSNC | 1224CSNBL | 1224CSNW | 1224CSN-DSG | — | — |
| 30 | 750 | 5 | 2.3 | 1230CSNC | 1230CSNBL | 1230CSNW | 1230CSN-DSG | — | — |
| 36 | 914 | 5.75 | 2.6 | 1236CSNC | 1236CSNBL | 1236CSNW | 1236CSN-DSG | — | — |
| 42 | 1066 | 6.75 | 3.1 | 1242CSNC | 1242CSNBL | 1242CSNW | 1242CSN-DSG | — | — |
| 48 | 1219 | 7.75 | 3.5 | 1248CSNC | 1248CSNBL | 1248CSNW | 1248CSN-DSG | — | — |
| 60 | 1524 | 9.5 | 4.3 | 1260CSNC | 1260CSNBL | 1260CSNW | 1260CSN-DSG | — | — |

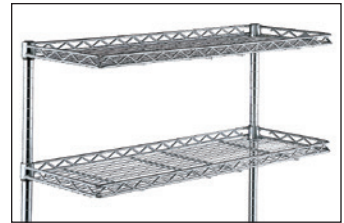

Cantilever Shelves

Super Erecta® Convenience Pack — {10.03}

- A complete shelving unit in a single box — the easy-to-order alternative to separate shelving components.
- Available in Super Erecta Brite, chrome and Metroseal Green

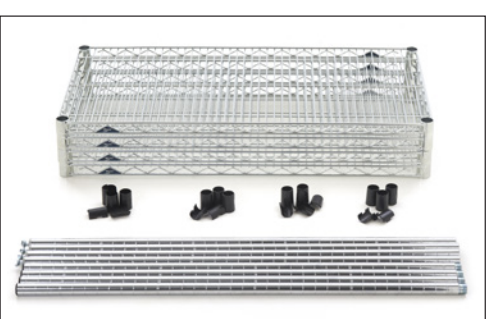

Unassembled Convenience Pack
 Each pack includes four shelves with split sleeves and four split posts with threaded connectors and leveling feet.



| Width/Length/Height (in.) | | Pkd. Wt. (lbs.) | Pkd. Wt. (kg) | Cat. No. | | Cat. No. | | Cat. No. | |
|---------------------------|---------------|-----------------|---------------|--------------------|------------|-------------|-----------|----------|---|
| (mm) | (mm) | | | Super Erecta Brite | Chrome | Microban® | Stainless | | |
| 18x36x74.5 | 457x914x1890 | 51 | 23 | EZ1836BR-4 | EZ1836NC-4 | EZ1836NK3-4 | — | — | — |
| 18x48x74.5 | 457x1219x1890 | 63 | 28.5 | EZ1848BR-4 | EZ1848NC-4 | EZ1848NK3-4 | — | — | — |
| 18x60x74.5 | 457x1524x1890 | 82 | 37 | EZ1860BR-4 | EZ1860NC-4 | EZ1860NK3-4 | — | — | — |
| 24x36x74.5 | 610x914x1890 | 66 | 30 | EZ2436BR-4 | EZ2436NC-4 | EZ2436NK3-4 | — | — | — |
| 24x48x74.5 | 610x1219x1890 | 76 | 34.5 | EZ2448BR-4 | EZ2448NC-4 | EZ2448NK3-4 | — | — | — |
| 24x60x74.5 | 610x1524x1890 | 102 | 46 | EZ2460BR-4 | EZ2460NC-4 | EZ2460NK3-4 | — | — | — |

Ⓜ Indicates antimicrobial product.



Shelving Starter and Add-On Units — {10.90}

- Starter Units consist of four posts and indicated number of Super Erecta shelves.
- Add-On Units consist of two posts, indicated number of shelves, and two “S” Hooks per shelf, for attaching shelf to adjacent unit.

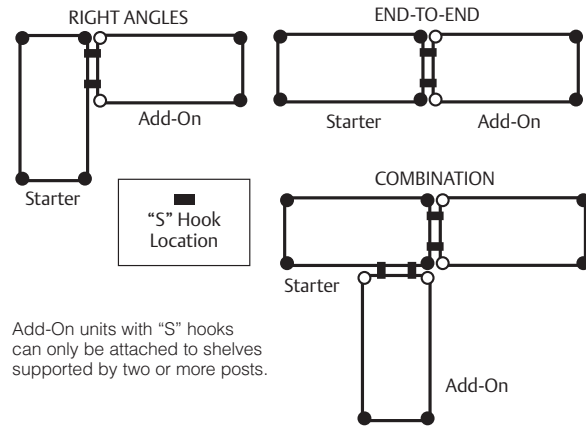

Add-On units with “S” hooks can only be attached to shelves supported by two or more posts.



Chrome Finish

Brite Finish

| Nominal Width/Length (in./mm) | | Cat. No. Starter Unit | Cat. No. Add-On Unit | Cat. No. Starter Unit | Cat. No. Add-On Unit | Cat. No. Starter Unit | Cat. No. Add-On Unit | Cat. No. Starter Unit | Cat. No. Add-On Unit | |
|-------------------------------|--|-----------------------|----------------------|-----------------------|----------------------|-----------------------|----------------------|-----------------------|----------------------|----------|
| 18x24 457x610 | | N316C | AN316C | - | 5N317C | 5AN317C | N316BR | AN316BR | 5N317BR | 5AN317BR |
| 18x30 457x760 | | N326C | AN326C | - | 5N327C | 5AN327C | N326BR | AN326BR | 5N327BR | 5AN327BR |
| 18x36 457x914 | | N336C | AN336C | N337C | 5N337C | 5AN337C | N336BR | AN336BR | 5N337BR | 5AN337BR |
| 18x42 457x1060 | | N346C | AN346C | N347C | 5N347C | 5AN347C | N346BR | AN346BR | 5N347BR | 5AN347BR |
| 18x48 457x1219 | | N356C | AN356C | N357C | 5N357C | 5AN357C | N356BR | AN356BR | 5N357BR | 5AN357BR |
| 18x60 457x1524 | | N366C | AN366C | N367C | 5N367C | 5AN367C | N366BR | AN366BR | 5N367BR | 5AN367BR |
| 18x72 457x1829 | | N376C | AN376C | N377C | 5N377C | 5AN377C | N376BR | AN376BR | 5N377BR | 5AN377BR |
| 21x24 530x610 | | N416C | AN416C | - | 5N417C | 5AN417C | N416BR | AN416BR | 5N417BR | 5AN417BR |
| 21x30 530x760 | | N426C | AN426C | - | 5N427C | 5AN427C | N426BR | AN426BR | 5N427BR | 5AN427BR |
| 21x36 530x914 | | N436C | AN436C | - | 5N437C | 5AN437C | N436BR | AN436BR | 5N437BR | 5AN437BR |
| 21x42 530x1060 | | N446C | AN446C | - | 5N447C | 5AN447C | N446BR | AN446BR | 5N447BR | 5AN447BR |
| 21x48 530x1219 | | N456C | AN456C | - | 5N457C | 5AN457C | N456BR | AN456BR | 5N457BR | 5AN457BR |
| 21x60 530x1524 | | N466C | AN466C | - | 5N467C | 5AN467C | N466BR | AN466BR | 5N467BR | 5AN467BR |
| 21x72 530x1829 | | N476C | AN476C | - | 5N477C | 5AN477C | N476BR | AN476BR | 5N477BR | 5AN477BR |
| 24x24 610x610 | | N516C | AN516C | - | 5N517C | 5AN517C | N516BR | AN516BR | 5N517BR | 5AN517BR |
| 24x30 610x760 | | N526C | AN526C | - | 5N527C | 5AN527C | N526BR | AN526BR | 5N527BR | 5AN527BR |
| 24x36 610x914 | | N536C | AN536C | N537C | 5N537C | 5AN537C | N536BR | AN536BR | 5N537BR | 5AN537BR |
| 24x42 610x1060 | | N546C | AN546C | N547C | 5N547C | 5AN547C | N546BR | AN546BR | 5N547BR | 5AN547BR |
| 24x48 610x1219 | | N556C | AN556C | N557C | 5N557C | 5AN557C | N556BR | AN556BR | 5N557BR | 5AN557BR |
| 24x60 610x1524 | | N566C | AN566C | N567C | 5N567C | 5AN567C | N566BR | AN566BR | 5N567BR | 5AN567BR |
| 24x72 610x1829 | | N576C | AN576C | N577C | 5N577C | 5AN577C | N576BR | AN576BR | 5N577BR | 5AN577BR |

Actual Dimensions: Width: Add .12" (3.2mm) to nominal size. Length: Subtract .12" (3.2mm) from nominal size.

For additional wire shelves, order from page 48.



Replacement “S” Hook

2 are required for each storage level.
Cat. No. 9995Z



Security “S” Hook

2 are required for each storage level. Bag of 2.
Chrome. Cat. No. H9995C
Black. Cat. No. H9995B



Metroseal™ Epoxy Finish

12 YEAR CORROSION WARRANTY

UNPROTECTED

WITH METROSEAL

Metroseal Epoxy Coating



Zinc chromate plated steel

Added layer of protection.

Supplement your cleaning process and stop bacteria in its tracks with built-in Microban® antimicrobial product protection.



WHAT IS MICROBAN?

Metroseal Green Finish



Metroseal Gray Finish



| Nominal Width/Length (in./mm) | | Cat. No. Starter Unit | Cat. No. Add-On Unit | Cat. No. Starter Unit | Cat. No. Add-On Unit | Cat. No. Starter Unit | Cat. No. Add-On Unit |
|-------------------------------|--|-----------------------|----------------------|-----------------------|----------------------|-----------------------|----------------------|
| 18x24 457x610 | | N316K3 | AN316K3 | 5N317K3 | 5AN317K3 | SE-182463K4-S-4 | SE-182474K4-S-4 |
| 18x30 457x760 | | N326K3 | AN326K3 | 5N327K3 | 5AN327K3 | SE-183063K4-S-4 | SE-183074K4-S-4 |
| 18x36 457x914 | | N336K3 | AN336K3 | 5N337K3 | 5AN337K3 | SE-183663K4-S-4 | SE-183674K4-S-4 |
| 18x42 457x1060 | | N346K3 | AN346K3 | 5N347K3 | 5AN347K3 | SE-184263K4-S-4 | SE-184274K4-S-4 |
| 18x48 457x1219 | | N356K3 | AN356K3 | 5N357K3 | 5AN357K3 | SE-184863K4-S-4 | SE-184874K4-S-4 |
| 18x54 457x1370 | | - | - | - | - | SE-185463K4-S-4 | SE-185474K4-S-4 |
| 18x60 457x1524 | | N366K3 | AN366K3 | 5N367K3 | 5AN367K3 | SE-186063K4-S-4 | SE-186074K4-S-4 |
| 18x72 457x1829 | | N376K3 | AN376K3 | 5N377K3 | 5AN377K3 | SE-187263K4-S-4 | SE-187274K4-S-4 |
| 21x24 530x610 | | N416K3 | AN416K3 | 5N417K3 | 5AN417K3 | SE-212463K4-S-4 | SE-212474K4-S-4 |
| 21x30 530x760 | | N426K3 | AN426K3 | 5N427K3 | 5AN427K3 | SE-213063K4-S-4 | SE-213074K4-S-4 |
| 21x36 530x914 | | N436K3 | AN436K3 | 5N437K3 | 5AN437K3 | SE-213663K4-S-4 | SE-213674K4-S-4 |
| 21x42 530x1060 | | N446K3 | AN446K3 | 5N447K3 | 5AN447K3 | SE-214263K4-S-4 | SE-214274K4-S-4 |
| 21x48 530x1219 | | N456K3 | AN456K3 | 5N457K3 | 5AN457K3 | SE-214863K4-S-4 | SE-214874K4-S-4 |
| 21x54 530x1370 | | - | - | - | - | SE-215463K4-S-4 | SE-215474K4-S-4 |
| 21x60 530x1524 | | N466K3 | AN466K3 | 5N467K3 | 5AN467K3 | SE-216063K4-S-4 | SE-216074K4-S-4 |
| 21x72 530x1829 | | N476K3 | AN476K3 | 5N477K3 | 5AN477K3 | SE-217263K4-S-4 | SE-217274K4-S-4 |
| 24x24 610x610 | | N516K3 | AN516K3 | 5N517K3 | 5AN517K3 | SE-242463K4-S-4 | SE-242474K4-S-4 |
| 24x30 610x760 | | N526K3 | AN526K3 | 5N527K3 | 5AN527K3 | SE-243063K4-S-4 | SE-243074K4-S-4 |
| 24x36 610x914 | | N536K3 | AN536K3 | 5N537K3 | 5AN537K3 | SE-243663K4-S-4 | SE-243674K4-S-4 |
| 24x42 610x1060 | | N546K3 | AN546K3 | 5N547K3 | 5AN547K3 | SE-244263K4-S-4 | SE-244274K4-S-4 |
| 24x48 610x1219 | | N556K3 | AN556K3 | 5N557K3 | 5AN557K3 | SE-244863K4-S-4 | SE-244874K4-S-4 |
| 24x54 610x1370 | | - | - | - | - | SE-245463K4-S-4 | SE-245474K4-S-4 |
| 24x60 610x1524 | | N566K3 | AN566K3 | 5N567K3 | 5AN567K3 | SE-246063K4-S-4 | SE-246074K4-S-4 |
| 24x72 610x1829 | | N576K3 | AN576K3 | 5N577K3 | 5AN577K3 | SE-247263K4-S-4 | SE-247274K4-S-4 |

Actual Dimensions: Width: Add .12" (3.2mm) to nominal size. Length: Subtract .12" (3.2mm) from nominal size.

For additional Super Erecta wire shelves, order from page 48.

Add-on units with “S” hooks can only be attached to shelves supported by two or more posts.

Indicates antimicrobial product.



Standard-Duty Stem Caster Carts

(Standard-Duty Mobile Shelving)

- The most common configuration for mobile shelving.
- They are primarily used for applications where the shelving is periodically moved to clean or to transport goods short distances within a facility.
- The weight capacity of the cart is determined by the casters. Typical configurations range from 600-900 lbs. (272-363kg) total unit capacity.



Wire Stem Caster Cart

Stem Caster Carts — Wire — {11.01}

Open-wire shelf design minimizes dust and increases air circulation and visibility. Casters included. Overall Height 67.9" (1724mm). Carts are configured with 63UP posts.

| Shelf Width/Length (in.) (mm) | Approx. Pkd. Wt. (lbs.) (kg) | Super Erecta Brite Finish | | Chrome Finish | |
|-------------------------------|------------------------------|---|---|---|---|
| | | Two Swivel Two Brake Resilient Rubber Casters | Two Swivel Two Brake Polyurethane Casters | Two Swivel Two Brake Resilient Rubber Casters | Two Swivel Two Brake Polyurethane Casters |
| 18x36 457x914 | 60 27 | N336BBR | N336EBR | N336BC | N336EC |
| 18x48 457x1219 | 72 32 | N356BBR | N356EBR | N356BC | N356EC |
| 18x60 457x1524 | 88 40 | N366BBR | N366EBR | N366BC | N366EC |
| 21x36 530x914 | 69 31 | N436BBR | N436EBR | N436BC | N436EC |
| 21x48 530x1219 | 81 36 | N456BBR | N456EBR | N456BC | N456EC |
| 21x60 530x1524 | 98 44 | N466BBR | N466EBR | N466BC | N466EC |
| 24x36 610x914 | 76 34 | N536BBR | N536EBR | N536BC | N536EC |
| 24x48 610x1219 | 92 41 | N556BBR | N556EBR | N556BC | N556EC |
| 24x60 610x1524 | 112 51 | N566BBR | N566EBR | N566BC | N566EC |

Note: Models with Resilient Rubber casters can hold up to 600 lbs. (272kg) evenly distributed. Models with Polyurethane casters can hold up to 900 lbs. (409kg) evenly distributed.



Solid Stem Caster with galvanized shelves

Stem Caster Carts — Solid — {11.10}

- Consist of four galvanized flat shelves, chrome plated 63" (1600mm) posts, plastic split sleeves, donut bumpers and 5" (127mm) poly casters (2 swivel; 2 brake).
- Strong and versatile
- Solid Shelf Stem Caster Carts feature a .12" (3mm) raised "ship's edge" around perimeter of shelves to help contain spillage.

Overall Height 67.12" (1724mm)

| Shelf Width/Length (in.) (mm) | Approx. Pkd. Wt. (lbs.) (kg) | Cat. No. |
|-------------------------------|------------------------------|----------|
| 24x36 610x914 | 100 45 | F536EG |
| 24x48 610x1219 | 124 56 | F556EG |
| 24x60 610x1524 | 152 69 | F566EG |

Note: Models are designed to hold up to 900 lbs. (363kg) evenly distributed.



Stem Caster Carts — Solid Stainless Steel Embossed

| Description | Width (in.) (mm) | Length (in.) (mm) | Height (in.) (mm) | Casters (amt.) (type) | Approx. Pkd. Wt. (lbs.) (kg) | Cat. No. |
|----------------|------------------|-------------------|-------------------|-----------------------|------------------------------|----------|
| Solid Embossed | 24 610 | 48 1219 | 68 1727 | 2 5MP | 125 56 | PR48ES |
| Solid Embossed | 24 610 | 60 1524 | 68 1727 | 2 5MPB | 153 66 | PR60ES |
| | | | | 2 5MPB | | |

Embossed Stainless Shelves are perfect for: Pot & Pan Drying Applications



Heavy-Duty Dolly Trucks

Safely Hold up to 1000 lbs. per mobile unit.

(Heavy-Duty Mobile Shelving)

- Carts configured with dolly bases are recommended for heavier duty applications. The dolly base is shock absorbent and the heavier duty plate casters are designed to withstand abusive conditions.
- Dolly trucks are recommended when the carts must travel longer distances, over thresholds, and/or between facilities on a regular basis.
- Dolly trucks can transport up to 1,000 lbs. (454kg) evenly distributed.

HIGH TRAFFIC. EXTREME IMPACT.



Super Erecta Dolly Trucks

Consist of four chrome wire shelves, aluminum dolly base, 63" (1600mm) plated posts, plastic split sleeves, donut bumpers and resilient rubber or poly casters as designated.

| Shelf Width/Length (in.) (mm) | Approx. Pkd. Wt. (lbs.) (kg) | Catalog Number with Casters | | |
|-------------------------------|------------------------------|-----------------------------|------------------|-----------------|
| | | Two BSDN Two BSDNB | Two B5P Two B5PB | Two 6P Set BL6P |
| 24x36 610x914 | 96 43 | N536JC | N536LC | N536MC |
| 24x48 610x1219 | 118 53 | N556JC | N556LC | N556MC |
| 24x60 610x1524 | 142 64 | N566JC | N566LC | N566MC |

Overall heights: JC, LC models — 68.44" (1739mm), MC models — 70.06" (1800mm).

- JC models: Standard swivel plate casters, two with brake; resilient rubber tread.
- LC models: Standard swivel plate casters, two with brake; polyurethane tread.
- MC models: Larger plate casters; two swivel; one swivel/brake set; polyurethane tread.



SUPER ERECTA® SHELVING CARTS



Slanted Shelf Rack

- Tote storage carts can hold up to twenty 10" (254mm) wide totes.
- Slanted shelves add visibility and accessibility. Loading is quick, easy and organized.
- Open-wire construction and slope of shelves permit instant identification.
- Shelves are adjustable at 1" (25mm) intervals along the height of the post.
- 5" (127mm) casters add mobility, while brakes lock firmly in position.
- Slanted shelf racks are commonly used as suture carts, picking carts with tote boxes, and for retail display.

| Shelves | Length (in.) (mm) | Height (in.) (mm) | Approx. Pkd. Wt. (lbs.) (kg) | Cat. No. |
|---|----------------------|----------------------|------------------------------------|----------|
| Four Slanted Shelves One Flat Top Shelf (Pkg. of 12 dividers) | 24 610 | 60 1524 | 103 46.3 | DC15EC |
| Five Slanted Shelves (Pkg. of 12 dividers) | 24 610 | 60 1524 | 112 50.4 | DC16EC |
| Four Slanted Shelves One Flat Top Shelf | 36 914 | 60 1524 | 95 42.7 | DC35EC |
| Five Slanted Shelves | 36 914 | 70 1778 | 104 46.8 | DC36EC |
| Four Slanted Shelves One Flat Top Shelf | 48 1219 | 60 1524 | 112 50.4 | DC55EC |
| Five Slanted Shelves | 48 1219 | 70 1778 | 123 55.3 | DC56EC |

Note: Weight Load Capacity (evenly distributed) 200lbs per shelf 400lbs per mobile unit 800lbs per stationary unit.



Slanted Shelf Rack
DC56EC

Additional Shelves

18" (457mm) wide.

| Length (in.) (mm) | Approx. Pkd. Wt. (lbs.) (kg) | Cat. No. |
|----------------------|------------------------------------|----------|
| 24 610 | 10.5 4.7 | 1824DNC |
| 36 914 | 14 6.3 | 1836DNC |
| 48 1219 | 18 8.1 | 1848DNC |

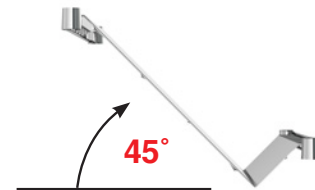
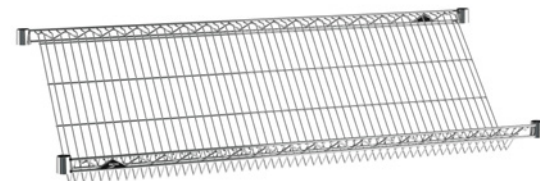

Additional Retainer

Helps separate merchandise.

| Size Width/Length (in.) (mm) | Approx. Pkd. Wt. (lbs.) (kg) | Cat. No. |
|------------------------------------|------------------------------------|----------|
| 4x17 102x432 | 8 3.6 | DCR17C |

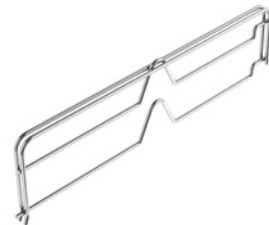

Slanted Shelving Transport Cart — {31.05}

Shelves slope backwards 2" (51mm) to keep items from falling during transport. Standard-duty carts have four polyurethane stem casters. Heavy-duty trucks are dolly mounted.

| Width/Length (in.) (mm) | Height (in.) (mm) | No. Shelves | Casters | Description | Cat. No. |
|----------------------------|----------------------|----------------|----------------|---------------|----------|
| 24x36 610x914 | 62.06 1577 | 3 | 2-BL6P, 2-6P | Heavy-Duty | AST35MC |
| 24x48 610x1219 | 62.06 1577 | 3 | 2-BL6P, 2-6P | Heavy-Duty | AST55MC |
| 24x60 610x1524 | 62.06 1577 | 3 | 2-BL6P, 2-6P | Heavy-Duty | AST65MC |
| 24x36 610x914 | 59.87 1521 | 3 | 4-Poly Casters | Standard-Duty | AST35DC |
| 24x48 610x1219 | 59.87 1521 | 3 | 4-Poly Casters | Standard-Duty | AST55DC |
| 24x60 610x1524 | 59.87 1521 | 3 | 4-Poly Casters | Standard-Duty | AST65DC |

Weight Load Capacity (evenly distributed) 800lbs per shelf. Up to 1000lbs per cart.

Additional Slanted Shelves

| Width/Length (in.) (mm) | Cat. No. Chrome |
|----------------------------|--------------------|
| 24x36 610x914 | SLT2436NC |
| 24x48 610x1219 | SLT2448NC |
| 24x60 610x1524 | SLT2460NC |



Standard-Duty Slanted
Shelf Cart

Metro Design Tools

The easy way to customize & specify in 3D.

Builder



LEARN MORE

Metro has created these amazing, proprietary tools to help you build, layout, and specify select Metro products. These tools are **FREE** to use and can be accessed on metro.com.

Give it a try... they are super-simple.

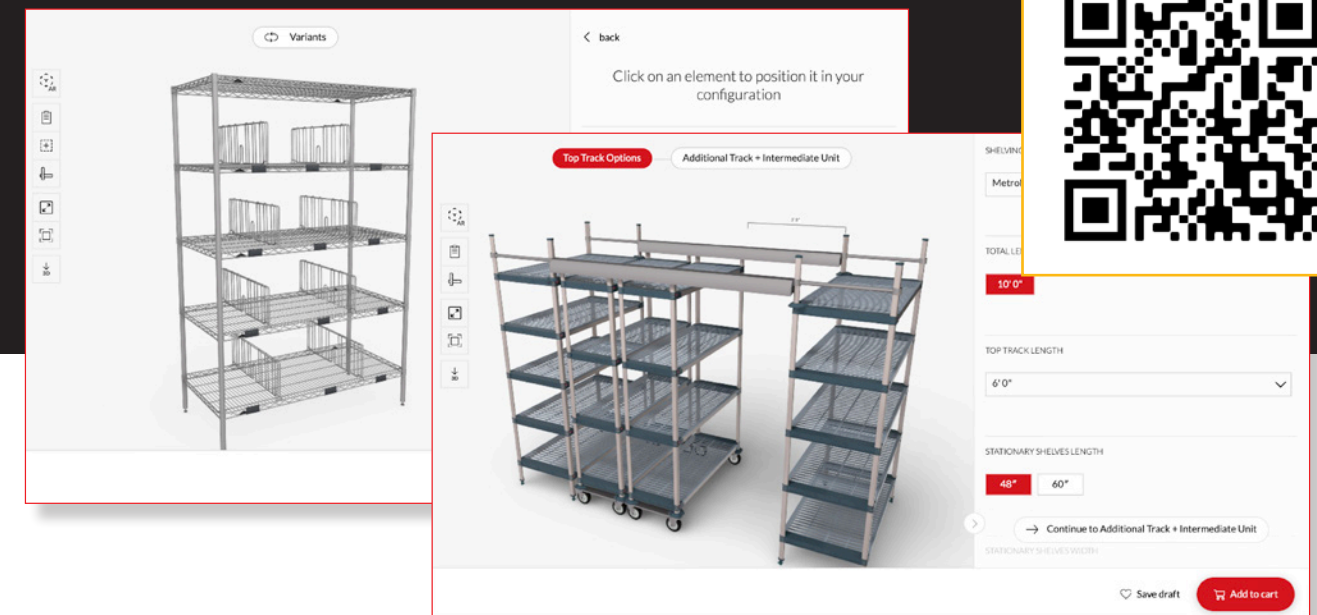



Casters for Dry Areas



GOOD

Plated Stem Casters — {11.20}

Plated caster horns and hardware for basic dry environments.



5LD 5MB

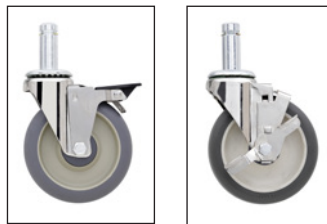

5MDBA 5MPB



5MPR

| Wheel Diameter (in.) (mm) | Face (in.) (mm) | Load Rating (lbs.) (kg) | Type | Wheel Tread | Temperature Range (Continuous Usage) | | Cat. No. |
|---------------------------|-----------------|-------------------------|---------|--------------------------------|--------------------------------------|-----------|----------|
| | | | | | (Fahrenheit) | (Celsius) | |
| 4 | 102 | .5 12 | 125 56 | Stem/Swivel Resilient Donut | -20°-160° | -29°-71° | 4LD |
| 5 | 127 | .5 12 | 125 56 | Stem/Swivel Resilient Donut | -20°-160° | -29°-71° | 5LD |
| 5 | 127 | 1.25 32 | 200 90 | Stem/Swivel Resilient, Flat | -20°-160° | -29°-71° | 5M |
| 5 | 127 | 1.25 32 | 200 90 | Stem/Brake Resilient, Flat | -20°-160° | -29°-71° | 5MB |
| 5 | 127 | 1.25 32 | 200 90 | Stem/Rigid Resilient, Flat | -20°-160° | -29°-71° | 5MR |
| 5 | 127 | 1.25 32 | 250 113 | Stem/Swivel High Modulus Donut | -20°-180° | -29°-82° | 5MDA |
| 5 | 127 | 1.25 32 | 250 113 | Stem/Brake High Modulus Donut | -20°-180° | -29°-82° | 5MDBA |
| 5 | 127 | 1.25 32 | 250 113 | Stem/Rigid High Modulus Donut | -20°-180° | -29°-82° | 5MDRA |
| 5 | 127 | 1.25 32 | 300 135 | Stem/Swivel Polyurethane, Flat | -20°-180° | -29°-82° | 5MP |
| 5 | 127 | 1.25 32 | 300 135 | Stem/Brake Polyurethane, Flat | -20°-180° | -29°-82° | 5MPB |
| 5 | 127 | 1.25 32 | 300 135 | Stem/Rigid Polyurethane, Flat | -20°-180° | -29°-82° | 5MPR |
| 6 | 152 | 1.5 38 | 400 182 | Stem/Swivel Polyurethane, Flat | -20°-180° | -29°-82° | 6MP |
| 6 | 152 | 1.5 38 | 400 182 | Stem/Brake Polyurethane, Flat | -20°-180° | -29°-82° | 6MPB |
| 6 | 152 | 1.5 38 | 400 182 | Stem/Rigid Polyurethane, Flat | -20°-180° | -29°-82° | 6MPR |

Note: Rigid casters are held in place by a connecting channel. When ordering, shelf width must be provided. Rigid connecting channel (stainless steel): Cat. No. 14RS, 18RS, 21RS, 24RS, 30RS, or 36RS. Load Height for all 5M and 5MP casters — 6.09" ± .06" (155 ± 1.5mm). Load Height for 4LD caster — 4.62" ± .06" (118 ± 1.5mm). Load Height for 5LD caster — 5.06" ± .06" (143 ± 1.5mm). Brakes are foot-operated.

Plated Stem Casters
Use with Super Erecta posts and shelves (see pages 42 and 48) to create a mobile shelving unit to meet your special needs. Stem casters are shipped with donut bumper at no additional charge.



Donut Bumper

Donut Bumpers — {11.40}

• Non-phthalate, flexible vinyl material

| Diameter (in.) (mm) | Height (lbs.) (kg) | Cat. No. | Each |
|---------------------|--------------------|----------|-------|
| 3.5 | .89 | 9992DB* | 9.40 |
| 5.5 | 1.40 | 9992N | 14.60 |

*Included with each Super Erecta stem caster as noted on previous page.

Low Profile 3" Casters — {11.20}

Ideal for creating shorter height mobile units for undercounter use. Threaded stem fits stationary posts with threaded base. (Remove leveling foot and install caster)

| Wheel Diameter (in.) (mm) | Face (in.) (mm) | Load Rating (lbs.) (kg) | Type | Wheel Thread | Temperature Range (Continuous Usage) | | Cat. No. | |
|---------------------------|-----------------|-------------------------|--------|-----------------------------|--------------------------------------|-------------|------------|------|
| | | | | | (Fahrenheit) | (Celsius) | | |
| 3 | .76 | .94 24 | 100 45 | Threaded Stem, Swivel | Resilient Rubber | -30° - 160° | -34° - 71° | 3TM |
| 3 | .76 | .94 24 | 100 45 | Threaded Stem, Swivel/Brake | Resilient Rubber | -30° - 160° | -34° - 71° | 3TMB |

Note 1: Not intended for carts that travel long distances.



3TM 3TMB

Decorative Casters — {10.06}

- Black nylon housing with non-marking polymer tread.
- 2.5" (63mm) models have threaded stem and attach to stationary shelving posts.
- 4" (100mm) casters include threaded insert for use with mobile posts.

| Type | Diameter (in.) (mm) | Fits Post Type | Cat. No. |
|--------------|---------------------|----------------|----------|
| Swivel/Brake | 2.5 63 | Stationary | HDC3BB |
| Swivel | 4 100 | Mobile | HDC5B |
| Swivel/Brake | 4 100 | Mobile | HDC5BB |

Casters shipped with post inserts for adaptability to mobile posts.



HDC5B HDC5BB

Wheel Material? What's the difference?

| Wheel Material | Oil & Grease Resistance | Rollability | Noise |
|---------------------|-------------------------|-------------|----------|
| Resilient Rubber | LOW | FAIR | LOW |
| Neoprene | HIGH | GOOD | LOW |
| Polyurethane | HIGH | GOOD | MODERATE |
| High-Modulus Rubber | HIGH | GOOD | LOW |
| Conductive | LOW | FAIR | LOW |



Casters for Wet or Corrosive Areas



BETTER

Polymer Stem Casters — {11.20}

Basic rust resistant - nylon and Polyurethane wheel tread.
• Harder tread for maneuvering of heavier loads.

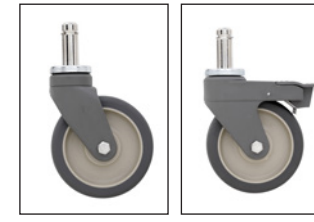

5PC 5PCB

| Wheel Diameter (in.) (mm) | Face (in.) (mm) | Load Rating (lbs.) (kg) | Type | Wheel Tread | Temperature Range (Continuous Usage) | | Cat. No. | Cat. No. Antimicrobial |
|---------------------------|-----------------|-------------------------|---------|--------------------------------|--------------------------------------|-----------|----------|------------------------|
| | | | | | (Fahrenheit) | (Celsius) | | |
| 5 | 127 | 1.25 32 | 300 135 | Stem/Swivel Polyurethane, Flat | -20°-120° | -29°-49° | 5PC | 5PCM |
| 5 | 127 | 1.25 32 | 300 135 | Stem/Brake Polyurethane, Flat | -20°-120° | -29°-49° | 5PCB | 5PCBM |
| 5 | 127 | 1.25 32 | 300 135 | Stem/Rigid Polyurethane, Flat | -20°-120° | -29°-49° | 5PCR | |

Note 1: Rigid casters are held in place by a connecting channel. When ordering, shelf width must be provided. Rigid connecting channel (aluminum) for 5PCR casters: Cat. No. P14RC, P18RC, P21RC, P24RC, P30RC, or P36RC. **Not suitable for cart wash and autoclave applications.**



BEST

Stainless Steel Cart-Washable Stem Casters — {11.20}

Type 304 Stainless rigs for intense cleaning and sterilization protocols.

- Best chemical resistance
- Best for high temperature cart wash chambers.
- Best for high impact mobile uses.

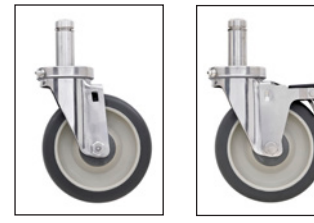

5MPGSA 5MPBGSA

| Wheel Diameter (in.) (mm) | Face (in.) (mm) | Load Rating (lbs.) (kg) | Type | Wheel Tread | Temperature Range (Continuous Usage) | | Cat. No. |
|---------------------------|-----------------|-------------------------|---------|--------------------------------|--------------------------------------|-----------|----------|
| | | | | | (Fahrenheit) | (Celsius) | |
| 5 | 127 | 1.25 32 | 250 113 | Stem/Swivel High Modulus Donut | -20°-180° | -29°-82° | 5MDGSA |
| 5 | 127 | 1.25 32 | 250 113 | Stem/Brake High Modulus Donut | -20°-180° | -29°-82° | 5MDBGSA |
| 5 | 127 | 1.25 32 | 250 113 | Stem/Rigid High Modulus Donut | -20°-180° | -29°-82° | 5MDRGSA |
| 5 | 127 | 1.25 32 | 300 135 | Stem/Swivel Polyurethane, Flat | -20°-180° | -29°-82° | 5MPGSA |
| 5 | 127 | 1.25 32 | 300 135 | Stem/Brake Polyurethane, Flat | -20°-180° | -29°-82° | 5MPBGSA |
| 5 | 127 | 1.25 32 | 300 135 | Stem/Rigid Polyurethane, Flat | -20°-180° | -29°-82° | 5MPRGSA |

Note: Rigid casters are held in place by a connecting channel. When ordering, shelf width must be provided. Rigid connecting channel (stainless steel): Cat. No. 14RS, 18RS, 21RS, 24RS, 30RS, or 36RS. Load Height for all 5MD and 5MP casters — 6.09" ± .06" (155 ± 1.5mm). All casters are grease sealed with zerk fittings in swivel and axle. Brakes are foot-operated.

High-temperature Autoclave Stem Casters

| Wheel Diameter (in.) (mm) | Face (in.) (mm) | Load Rating (lbs.) (kg) | Type | Wheel Tread | Temperature Range (Continuous Usage) | | Cat. No. |
|---------------------------|-----------------|-------------------------|---------|-------------------------|--------------------------------------|-----------|----------|
| | | | | | (Fahrenheit) | (Celsius) | |
| 5 | 127 | 1.5 38 | 300 135 | Stem/Swivel Nylon, Flat | -20°-475° | -29°-250° | 5MHTN |
| 5 | 127 | 1.5 38 | 300 135 | Stem/Brake Nylon, Flat | -20°-475° | -29°-250° | 5MHTNB |

Swaged Posts — For cart wash and autoclave applications

Type 304 stainless post has an aluminum cap swaged into the the post top. For use with standard stem casters.

| Description | Dimensions (in.) (mm) | | Cat. No. |
|------------------|-----------------------|------|----------|
| Stem Caster Post | 33 | 875 | 33UPS-SW |
| Stem Caster Post | 54 | 1370 | 54UPS-SW |
| Stem Caster Post | 63 | 1600 | 63UPS-SW |

Note: For special height posts, please consult your Metro representative.

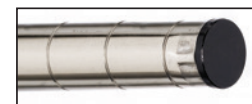

Swaged Post



CASTER INSTALLATION



Brake Lock/Swivel Lock Combination Casters — {11.37}

Patented, foot-operated design enables a single pair of casters to serve as swivel, rigid or brake casters. Conveniently positioned on the dolly, not on the wheels, the downward pressure pedals prevent scuffing of shoes.



- **Convenient.** Pedals are on the dolly, not the wheels, making operation more convenient. Downward pressure on the pedals save shoes from scuffing.
- **Casters.** Long wearing polyurethane. Resists abrasion. Non-marking, shock absorbing. Wheels are available in 6" (152mm) and 8" (203mm) size.
- **Recommended Caster Selection.** Two swivel casters at one end and brake/swivel lock set at the other end. Other caster combinations can be used, however, including brake/swivel lock sets at both ends. Wraparound bumper recommended.

Note: Aluminum dust covers and tow bar assemblies are not compatible with the Brake Lock/Swivel Lock Combination casters.



When "Rigid" is engaged the swivel casters will lock into the trailing position for easy steering of heavy loads over long distances. When "Swivel" is engaged the caster set swivels freely for easier maneuvering.



When the "Brake" pedal is engaged both of the BL casters are locked. The cart remains still for loading and unloading.

| Type | Wheel Diameter (in.) (mm) | Face (in.) (mm) | For Use With | Load Rating (lbs.) (kg) | Weight (lbs.) (kg) | Cat. No. |
|-------------|---------------------------|-----------------|--------------------------------------|-------------------------|--------------------|----------|
| *Brake/Lock | 6 152 | 2 51 | 24" (610mm) Deep Dolly and 6P Caster | 600 272 | 7 1/4 3.3 | BL6P24 |
| *Brake/Lock | 8 203 | 2 51 | 24" (610mm) Deep Dolly and 8P Caster | 600 272 | 9 4.1 | BL8P24 |
| Swivel | 6 152 | 2 51 | BL6P24 Brake/Lock Set | 600 272 | 5 1/4 2.3 | 6P |
| Rigid | 6 152 | 2 51 | 6P Swivel Caster | 600 272 | 5 2.26 | 6PR |
| Swivel | 8 203 | 2 51 | BL8P24 Brake/Lock Set | 600 272 | 6 1/2 2.9 | 8P |
| Rigid | 8 203 | 2 51 | 8P Swivel Caster | 600 272 | 6 2.7 | 8PR |

Load Heights: (±1/16") (±1.6mm) 6P Series — 7 1/8" (200mm), 8P Series — 9 13/16" (249mm).



Push Handle



Extended Handle

Handles — {11.40}

Use on corresponding width Super Erecta units to provide additional maneuverability to dolly carts or stem caster carts. Aluminum split sleeves included for attaching to cart.

| Length (in.) (mm) | Push Handles | | Extended Handles | |
|-------------------|-----------------|--------------------|------------------|--------------------|
| | Cat. No. Chrome | Cat. No. Stainless | Cat. No. Chrome | Cat. No. Stainless |
| 14 | PH14NC | PH14NS | EH14NC | EH14NS |
| 18 | PH18NC | PH18NS | EH18NC | EH18NS |
| 21 | PH21NC | PH21NS | EH21NC | EH21NS |
| 24 | PH24NC | PH24NS | EH24NC | EH24NS |
| 30 | PH30NC | | EH30NC | |
| 36 | PH36NC | | EH36NC | |

Note: Handles fit unit widths only. Extended handles add 6" (152.4mm) to length of unit.



Tow Bar Assembly — {11.37}

Attaches to underside of dolly to facilitate transport of dolly carts in tandem. Must be factory assembled and ordered with desired dolly frame (see page 60).



Tow Bar Assembly

| Length (in.) (mm) | Cat. No. |
|-------------------|----------|
| 48 1219 | TBA48 |

Note: "C" plate caster must be used with Tow Bar Assembly. Tow Bar Assembly for use with 24" (610mm) units only.

Note: Number of carts to be towed, weight on carts, and towing route affect operation of tow bar assembly. Before ordering, contact your Metro representative.

Tow Bar Assembly not appropriate for use with Brake Lock/Swivel Lock system.

Foot Plates — {10.06}

Use to bolt units to the floor, or when a broader, more stable foot is desired. Zinc. Cat. No. 9993Z
Stainless Steel. Cat. No. 9993S
Black. Cat. No. 9993BL

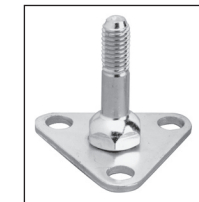

Aluminum Split Sleeves — {10.06}

For high temperature, over the road, or conductive applications. Zinc or stainless steel retainer rings available to secure shelf. One bag required per shelf; 4 pairs per bag.



| | Cat. No. |
|---|----------|
| Aluminum Split Sleeves with Zinc Rings | 9986Z |
| Aluminum Split Sleeves with Stainless Rings | 9986S |

Glides — {10.06}

Smooth polymer cover fits over leveling bolt to protect floors. Cat. No. 9991P

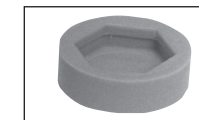

Decorative Leveling Foot — {10.06}

Decorative alternative for post. Compensates for uneven surfaces. Chrome. Cat. No. HDFC
Black. Cat. No. HDFB



Replacement Plastic Split Sleeves — {10.06}

One bag required per shelf; 4 pairs per bag.

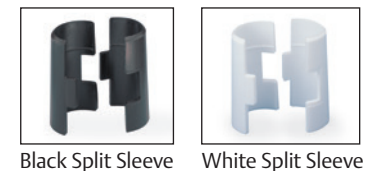

| | Cat. No. |
|-----------------------------|----------|
| Black Plastic Split Sleeves | 9985 |
| White Plastic Split Sleeves | 9985W |

Note: White post caps and white split sleeves are standard with white designer shelving only.

Wall Clamp — {10.06}

Use to secure a stationary unit to the wall for greater stability. Plated finish. Compatible with Super Erecta wire shelves and Super Adjustable Super Erecta wire shelves. Cat. No. 9984C



Post Clamps — {10.06}

Joins units together for maximum strength. Zinc-plated. Cat. No. 9994Z
Black. Cat. No. 9994BL



Replacement Super Adjustable Kit — {10.06}

Package includes 4 wedges, 4 sleeves, and 4 corner releases. Cat. No. SAKITA2





Dividers

Tall dividers contain larger items and create more defined compartments.



Shelf Divider for Super Erecta Shelves

Shelf Dividers for Super Erecta Shelves — {10.04}

Keep shelf contents orderly with these 8" (203mm) high, pressure-fit dividers.

| Shelf Width (in.) | Shelf Width (mm) | Cat. No. Plated | Cat. No. Black | Cat. No. White | Cat. No. Smoked Glass |
|-------------------|------------------|-----------------|----------------|----------------|-----------------------|
| 14 | 355 | DD14C | DD14BL | DD14W | DD14-DSG |
| 18 | 457 | DD18C | DD18BL | DD18W | DD18-DSG |
| 21 | 530 | DD21C | DD21BL | DD21W | DD21-DSG |
| 24 | 610 | DD24C | DD24BL | DD24W | DD24-DSG |
| 30 | 760 | DD30C | DD30BL | DD30W | DD30-DSG |
| 36 | 914 | DD36C | DD36BL | DD36W | DD36-DSG |

| Shelf Width (in.) | Shelf Width (mm) | Cat. No. Metroseal Gray with Microban® | Cat. No. Metroseal Green with Microban® | Cat. No. Stainless | Cat. No. Copper Hammerstone |
|-------------------|------------------|--|---|--------------------|-----------------------------|
| 14 | 355 | DD14K4 | DD14K3 | DD14S | DD14-DCH |
| 18 | 457 | DD18K4 | DD18K3 | DD18S | DD18-DCH |
| 21 | 530 | DD21K4 | DD21K3 | DD21S | DD21-DCH |
| 24 | 610 | DD24K4 | DD24K3 | DD24S | DD24-DCH |
| 30 | 760 | - | DD30K3 | DD30S | - |
| 36 | 914 | - | - | DD36S | - |

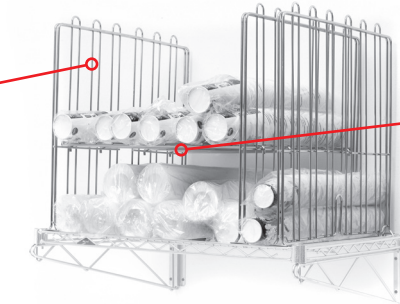

Horizontal Divider

Chrome finish.
Fits 21" Tall Divider
Available in 12" or 18" lengths
Cat. No. DDH24C-12L
Cat. No. DDH24C-18L

21" Tall Divider
Chrome finish.
Fits 24" Deep Shelf
Cat. No. DD24C-21H

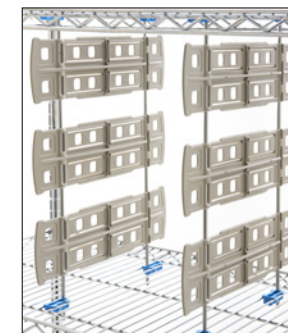

Shelf-to-Shelf Dividers

Shelf-to-Shelf Dividers — {9.25}

Full height dividers efficiently compartmentalize the space between two shelves. Corrosion proof. Compatible with Super Erecta and Super Adjustable wire shelves.

| Fits Shelf Depth (in.) | Fits Shelf Depth (mm) | Nominal Height (in.) | Nominal Height (mm) | Cat. No. |
|------------------------|-----------------------|----------------------|---------------------|----------|
| 18, 21 | 457, 530 | 16 | 406 | MD18-16 |
| 18, 21 | 457, 530 | 20 | 508 | MD18-20 |
| 18, 21 | 457, 530 | 24 | 610 | MD18-24 |
| 24 | 610 | 16 | 406 | MD24-16 |
| 24 | 610 | 20 | 508 | MD24-20 |
| 24 | 610 | 24 | 610 | MD24-24 |

*Note: -16 parts have three panels, -20 parts have four panels, -24 parts have five panels.

Select quick-mount dividers for light-duty applications

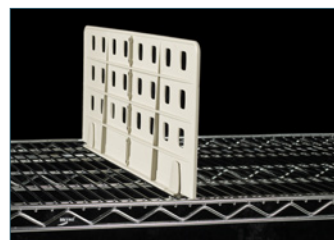

8" Universal Shelf Divider

Universal 8" (203mm) Shelf Dividers — Light Duty — {9.25}

Each divider includes a panel and two clips to connect to any Super Erecta or Super Adjustable wire self. Corrosion proof.

| Nominal Length (in.) | Nominal Length (mm) | Fits Shelf Depth | Cat. No. |
|----------------------|---------------------|-----------------------|----------|
| 18 | 457 | 18", 21" (457, 530mm) | MUD18-8 |
| 24 | 610 | 24" (610mm) | MUD24-8 |

Divide shelf space with rods to sort hard to manage items.



RODS & TABS INSTALLATION

Rods and Tabs — {10.04}

Form side and back enclosures for a shelving unit. Can also serve as uniform dividers within unit by passing through shelves from top to bottom. Recommended spacing: every 6" (150mm) to 12" (305mm), depending upon shelf contents. Plated rods are shipped with 4 plated tabs per rod. Stainless steel rods come with 4 rust-proof tabs.

| Min. Post Height (in.) | Rod Length (in.) | Rod Length (mm) | Approx. Pkd. Wt. (lbs.) | Approx. Pkd. Wt. (kg) | Cat. No. Plated | Cat. No. Stainless |
|------------------------|------------------|-----------------|-------------------------|-----------------------|-----------------|--------------------|
| 54 | 52 | 1320 | 1 | 0.5 | R52C | R52S |
| 63 | 61 | 1549 | 1 | 0.5 | R61C | R61S |
| 74 | 72 | 1830 | 1.25 | 0.6 | R72C | R72S |
| 86 | 84 | 2135 | 1.5 | 0.7 | R84C | R84S |



Stainless Steel rod with rust-proof tab.

Additional Rust-Proof Tabs —
Bag of 4
Cat. No. 9084P



Plated rod with plated tab.

Additional Plated Tabs —
Bag of 12
Cat. No. 9084Z



Ledges, frames & enclosures.

Shelf Ledges — Side and Back — {10.04}

For stationary or mobile installations, ledges prevent items from protruding or falling from shelves.

1" (25mm) High Ledges

| Approx. Shelf Width (in.) (mm) | Cat. No. Plated | Cat. No. Black | Cat. No. White | Cat. No. Smoked Glass | Cat. No. Metroseal Green with Microban® | Cat. No. Metroseal Gray with Microban® | Cat. No. Stainless | Cat. No. Copper Hammetone |
|--------------------------------|-----------------|----------------|----------------|-----------------------|---|--|--------------------|---------------------------|
| 14 355 | L14N-1C | L14N-1BL | L14N-1W | L14N-1DSG | - | - | L14N-1S | L14N-1-DCH |
| 18 457 | L18N-1C | L18N-1BL | L18N-1W | L18N-1DSG | - | - | L18N-1S | L18N-1-DCH |
| 21 530 | L21N-1C | L21N-1BL | L21N-1W | L21N-1DSG | - | - | L21N-1S | L21N-1-DCH |
| 24 610 | L24N-1C | L24N-1BL | L24N-1W | L24N-1DSG | - | - | L24N-1S | L24N-1-DCH |
| 30 760 | L30N-1C | L30N-1BL | L30N-1W | L30N-1DSG | - | - | L30N-1S | L30N-1-DCH |
| 36 914 | L36N-1C | L36N-1BL | L36N-1W | L36N-1DSG | - | - | L36N-1S | L36N-1-DCH |
| 42 1066 | L42N-1C | L42N-1BL | L42N-1W | L42N-1DSG | - | - | L42N-1S | L42N-1-DCH |
| 48 1219 | L48N-1C | L48N-1BL | L48N-1W | L48N-1DSG | - | - | L48N-1S | L48N-1-DCH |
| 54 1370 | L54N-1C | L54N-1BL | L54N-1W | L54N-1DSG | - | - | L54N-1S | L54N-1-DCH |
| 60 1524 | L60N-1C | L60N-1BL | L60N-1W | L60N-1DSG | - | - | L60N-1S | L60N-1-DCH |
| 72 1828 | L72N-1C | L72N-1BL | L72N-1W | L72N-1DSG | - | - | L72N-1S | L72N-1-DCH |

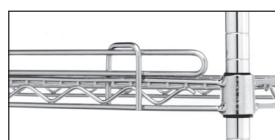

1" (25mm) Ledge

4" (100mm) High Stackable Ledges

| Approx. Shelf Width (in.) (mm) | Cat. No. Plated | Cat. No. Black | Cat. No. White | Cat. No. Smoked Glass | Cat. No. Metroseal Green with Microban® | Cat. No. Metroseal Gray with Microban® | Cat. No. Stainless | Cat. No. Copper Hammetone |
|--------------------------------|-----------------|----------------|----------------|-----------------------|---|--|--------------------|---------------------------|
| 14 355 | L14N-4C | L14N-4BL | L14N-4W | L14N-4DSG | L14N-4K3 | L14N-4K4 | L14N-4S | L14N-4-DCH |
| 18 457 | L18N-4C | L18N-4BL | L18N-4W | L18N-4DSG | L18N-4K3 | L18N-4K4 | L18N-4S | L18N-4-DCH |
| 21 530 | L21N-4C | L21N-4BL | L21N-4W | L21N-4DSG | L21N-4K3 | L21N-4K4 | L21N-4S | L21N-4-DCH |
| 24 610 | L24N-4C | L24N-4BL | L24N-4W | L24N-4DSG | L24N-4K3 | L24N-4K4 | L24N-4S | L24N-4-DCH |
| 30 760 | L30N-4C | L30N-4BL | L30N-4W | L30N-4DSG | L30N-4K3 | L30N-4K4 | L30N-4S | L30N-4-DCH |
| 36 914 | L36N-4C | L36N-4BL | L36N-4W | L36N-4DSG | L36N-4K3 | L36N-4K4 | L36N-4S | L36N-4-DCH |
| 42 1066 | L42N-4C | L42N-4BL | L42N-4W | L42N-4DSG | L42N-4K3 | L42N-4K4 | L42N-4S | L42N-4-DCH |
| 48 1219 | L48N-4C | L48N-4BL | L48N-4W | L48N-4DSG | L48N-4K3 | L48N-4K4 | L48N-4S | L48N-4-DCH |
| 54 1370 | L54N-4C | L54N-4BL | L54N-4W | L54N-4DSG | L54N-4K3 | L54N-4K4 | L54N-4S | L54N-4-DCH |
| 60 1524 | L60N-4C | L60N-4BL | L60N-4W | L60N-4DSG | L60N-4K3 | L60N-4K4 | L60N-4S | L60N-4-DCH |
| 72 1828 | L72N-4C | L72N-4BL | L72N-4W | L72N-4DSG | L72N-4K3 | L72N-4K4 | L72N-4S | L72N-4-DCH |

Note: Actual ledge length is approximately 1" (25mm) shorter than nominal shelf length/width.

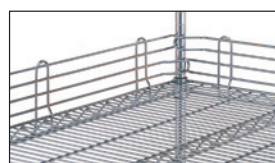

4" (102mm) Ledge

Three-Sided Double Snake Frames — {10.04}

Provide additional support or access to floor with these sturdy three-sided double snake frames. Chrome plated, Metroseal Green and Type 304 Stainless steel options.

| Nominal Width/Length (in.) (mm) | Cat. No. Chrome | Cat. No. Metroseal Green with Microban® | Cat. No. Stainless | Nominal Width/Length (in.) (mm) | Cat. No. Chrome | Cat. No. Metroseal Green with Microban® | Cat. No. Stainless |
|---------------------------------|-----------------|---|--------------------|---------------------------------|-----------------|---|--------------------|
| 18x24 457x610 | SF31N3C | SF31N3K3 | - | 24x24 610x610 | SF51N3C | SF51N3K3 | - |
| 18x30 457x760 | SF32N3C | SF32N3K3 | - | 24x30 610x760 | SF52N3C | SF52N3K3 | - |
| 18x36 457x914 | SF33N3C | SF33N3K3 | SF33N3S | 24x36 610x914 | SF53N3C | SF53N3K3 | SF53N3S |
| 18x42 457x1066 | SF34N3C | SF34N3K3 | - | 24x42 610x1066 | SF54N3C | SF54N3K3 | - |
| 18x48 457x1219 | SF35N3C | SF35N3K3 | SF35N3S | 24x48 610x1219 | SF55N3C | SF55N3K3 | SF55N3S |
| 18x54 457x1372 | SF1854N3C | SF1854N3K3 | - | 24x54 610x1372 | SF2454N3C | SF2454N3K3 | - |
| 18x60 457x1524 | SF36N3C | SF36N3K3 | - | 24x60 610x1524 | SF56N3C | SF56N3K3 | SF56N3S |
| 18x72 457x1829 | SF37N3C | SF37N3K3 | - | 24x72 610x1829 | SF57N3C | SF57N3K3 | SF57N3S |

Note: Consult your Metro representative for other sizes.

Note: Consult your Metro representative for other sizes.



Three-sided Double Snake Frame

Enclosure Panels — {10.04} {10.30}

An efficient way to enclose space for stationary or mobile applications.

- Can be used with Super Erecta and Super Adjustable wire shelving, and Super Erecta solid shelving.
- Appropriate mounting hardware supplied with each panel for stationary applications.

| Width/Height (in.) (mm) | For Nominal Post Height (in.) (mm) | Grid Opening (in.) (mm) | Weight (lbs.) (kg) | Cat. No. Chrome | Cat. No. Metroseal Gray | Cat. No. Stainless |
|-------------------------|------------------------------------|-------------------------|--------------------|-----------------|-------------------------|--------------------|
| 12.37x50.75 313x1289 | 54 1370 | 2.87x3.62 73x92 | 3 1.4 | EP35C | EP35K4 | EP35S |
| 12.37x59.75 313x1518 | 63 1600 | 2.87x3.62 73x92 | 4 1.8 | EP36C | EP36K4 | EP36S |
| 12.37x70.5 313x1791 | 74 1880 | 2.87x3.62 73x92 | 6 2.7 | EP37C | EP37K4 | EP37S |
| 18.37x50.75 464x1289 | 54 1370 | 3.37x3.62 86x92 | 5 2.3 | EP55C | EP55K4 | EP55S |
| 18.37x59.75 464x1518 | 63 1600 | 3.37x3.62 86x92 | 6 2.7 | EP56C | EP56K4 | EP56S |
| 18.37x70.5 464x1791 | 74 1800 | 3.37x3.62 86x92 | 7 3.2 | EP57C | EP57K4 | EP57S |

Note: All panels are .87" (22mm) deep. Units with a solid shelf in the top position require the use of a three-sided double snake frame directly below it (see page 66).



Enclosure Panel

Ordering Guide for Super Erecta Enclosure Panels

Ends — Panels required for each end according to shelf width, as follows:

| Nominal Post Height (in.) (mm) | 18" (457mm) Nominal Shelf Width | 21" (530mm) Nominal Shelf Width | 24" (610mm) Nominal Shelf Width | 30" (760mm) Nominal Shelf Width | 36" (914mm) Nominal Shelf Width |
|--------------------------------|---------------------------------|---------------------------------|---------------------------------|---------------------------------|---------------------------------|
| 54 1370 | (1) EP35 | (1) EP35 | (1) EP55 | (2) EP35 | (1) EP35 |
| 63 1600 | (1) EP36 | (1) EP36 | (1) EP56 | (2) EP36 | (1) EP36 |
| 74 1880 | (1) EP37 | (1) EP37 | (1) EP57 | (2) EP37 | (1) EP37 |

Backs for wire shelves— Requires multiple panels in quantities shown for specific length shelf:

| Nominal Post Height (in.) (mm) | 30" (760mm) Nominal Shelf Length | 36" (914mm) Nominal Shelf Length | 42" (1066mm) Nominal Shelf Length | 48" (1219mm) Nominal Shelf Length | 54" (1370mm) Nominal Shelf Length | 60" (1524mm) Nominal Shelf Length | 72" (1825mm) Nominal Shelf Length |
|--------------------------------|----------------------------------|----------------------------------|-----------------------------------|-----------------------------------|-----------------------------------|-----------------------------------|-----------------------------------|
| 54 1370 | (2) EP35 | (1) EP35 | (2) EP55 | (2) EP35 | (1) EP35 | (3) EP55 | (1) EP35 |
| 63 1600 | (2) EP36 | (1) EP36 | (2) EP56 | (2) EP36 | (1) EP36 | (3) EP56 | (1) EP36 |
| 74 1880 | (2) EP37 | (1) EP37 | (2) EP57 | (2) EP37 | (1) EP37 | (3) EP57 | (1) EP37 |

Backs for solid* shelves— Requires multiple panels in quantities shown for specific length shelf:

| Nominal Post Height (in.) (mm) | 30" (760mm) Nominal Shelf Length | 36" (914mm) Nominal Shelf Length | 42" (1066mm) Nominal Shelf Length | 48" (1219mm) Nominal Shelf Length | 54" (1370mm) Nominal Shelf Length | 60" (1524mm) Nominal Shelf Length | 72" (1825mm) Nominal Shelf Length |
|--------------------------------|----------------------------------|----------------------------------|-----------------------------------|-----------------------------------|-----------------------------------|-----------------------------------|-----------------------------------|
| 54 1370 | (1) EP55 | (2) EP35 | (1) EP35 | (2) EP55 | N/A | (1) EP35 | N/A |
| 63 1600 | (1) EP56 | (2) EP36 | (1) EP36 | (2) EP56 | N/A | (1) EP36 | N/A |
| 74 1880 | (1) EP57 | (2) EP37 | (2) EP37 | (2) EP57 | N/A | (1) EP37 | N/A |

*Note: Units with a solid shelf in the top position require the use of a three-sided double snake frame directly below it (see page 66).



Super Adjustable Super Erecta Cart with Enclosure Panels

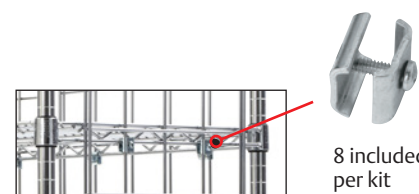

8 included per kit

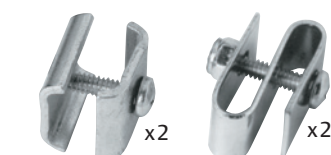

Mounting Kit for Enclosure Panel

Hardware Kit for Mobile Applications

Additional clamp assemblies are recommended to secure the enclosure panels to the intermediate shelves on a mobile unit or transport cart. For demanding mobile applications, use two clamp assemblies at each intermediate shelf level for each enclosure panel.

Plated steel. **Cat. No. 9970Z** (Kit of 8 clamp assemblies)
Stainless steel. **Cat. No. 9970S** (Kit of 8 clamp assemblies)

Replacement Mounting Kit for Enclosure Panel

Kit includes two security S-hooks and two clamp assemblies.

Plated steel. **Cat. No. 9970EPZ**
Stainless steel. **Cat. No. 9970EPS**



Shelf Markers & Label Holders

Color Shelf Marker — {10.05}

Color code for effective organization. Snaps securely to the front edge of Super Erecta and Super Adjustable Super Erecta Wire Shelving.

| Shelf Marker Size (mm) | | | Color | Cat. No. | Shelf Marker Size (mm) | | | Color | Cat. No. |
|------------------------|--------|-------|---------------|----------|------------------------|--------|----------------|-------|----------|
| 6x1.25 | 152x32 | Blue | CSM6-B | 6x1.25 | 152x32 | White | CSM6-W | | |
| 6x1.25 | 152x32 | Green | CSM6-G | 6x1.25 | 152x32 | Yellow | CSM6-Y | | |
| 6x1.25 | 152x32 | Red | CSM6-R | 6x1.25 | 152x32 | Gray | CSM6-GR | | |
| 6x1.25 | 152x32 | Tan | CSM6-T | | | | | | |

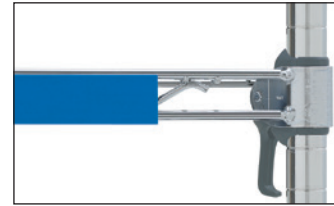

Color Shelf Markers



Gray Label Holders — {10.05}

Holds most commercial 1.25" (32mm) labels. Available in a variety of lengths.

| Length (mm) | | Fits Shelf Length (mm) | | Cat. No. |
|-------------|------|------------------------|------|----------------|
| 3 | 75 | All | | 9990P |
| 13 | 330 | 18 | 457 | 9990P1 |
| 19 | 480 | 24 | 610 | 9990P2 |
| 25 | 635 | 30 | 760 | 9990P30 |
| 31 | 725 | 36 | 914 | 9990P3 |
| 43 | 1090 | 48 | 1219 | 9990P4 |
| 55 | 1395 | 60 | 1520 | 9990P5 |

For Cantilever Shelves, use 3" (75mm) label holder only.



Gray Label Holder

Clear Label Holders — {10.05}

Allow decorator colors to show through. Holds most commercial 1.25" (32mm) labels.

| Length (mm) | | Fits Shelf Length (mm) | | Cat. No. |
|-------------|------|------------------------|------|-----------------|
| 3 | 75 | All | | 9990CL |
| 13 | 330 | 18 | 457 | 9990CL1 |
| 19 | 480 | 24 | 610 | 9990CL2 |
| 25 | 635 | 30 | 760 | 9990CL30 |
| 31 | 725 | 36 | 914 | 9990CL3 |
| 43 | 1090 | 48 | 1219 | 9990CL4 |
| 55 | 1395 | 60 | 1520 | 9990CL5 |

For Cantilever Shelves, use 3" (75mm) label holder only.



Clear Label Holder

Slanted Label Holders — {10.05}

Gray solid plastic holder puts 1.25" (32mm) labels on slant for easier viewing.

| Length (mm) | | Fits Shelf Length (mm) | | Cat. No. |
|-------------|------|------------------------|------|-----------------|
| 3 | 75 | All | | 9990SL |
| 13 | 330 | 18 | 457 | 9990SL1 |
| 19 | 480 | 24 | 610 | 9990SL2 |
| 25 | 635 | 30 | 760 | 9990SL30 |
| 31 | 725 | 36 | 914 | 9990SL3 |
| 43 | 1090 | 48 | 1219 | 9990SL4 |
| 55 | 1395 | 60 | 1520 | 9990SL5 |

For Cantilever Shelves, use 3" (75mm) label holder only.



Slanted Label Holder



Shelf Slides

Tray Slides — {10.04}

- Compatible with Metro tote boxes, Bun/Sheet pans, Hotel Pans (Steam Table Pans)
- Columns can be positioned along the shelf to fit different size vessels.

| Width (in.) | Width (mm) | Overall Depth (in.) | Overall Depth (mm) | Slide Profile (in.) | Slide Profile (mm) | On Center Slide Spacing (in.) | On Center Slide Spacing (mm) | Fits Shelf Width (in.) | Fits Shelf Width (mm) | Overall Height (in.) | Overall Height (mm) | Cat. No. Chrome | Cat. No. Metroseal Green with Microban® |
|-------------|------------|---------------------|--------------------|---------------------|--------------------|-------------------------------|------------------------------|------------------------|-----------------------|----------------------|---------------------|-----------------|---|
| 14.62 | 371 | 2.25 | 56 | 1.50 | 37 | 1.50 | 37 | 18 | 457 | 22.75 | 578 | 15SNC | 15SNK3 |
| 20 | 508 | 2.25 | 56 | 1.50 | 37 | 1.50 | 37 | 24 | 610 | 22.75 | 578 | 20SNC | 20SNK3 |



Tray Slides

Super Erecta Slide System — {10.04}

A super space-saving solution. Using Super Erecta wire units 21" or 24" (530 and 610mm) wide, tote boxes and this innovative slide system, you have the flexibility to create a custom configuration that can be positioned quickly on new or existing units without the use of tools. Finish is nickel-chrome wire with clear protective coating.

| Outside Slide Dimensions Height/Width/Length (in.) | | Height/Width/Length (mm) | | Fits Shelf Width (in.) | Fits Shelf Width (mm) | Adaptable Boxes | Approx. Pkd. Wt. (lbs.) | Approx. Pkd. Wt. (kg) | Cat. No. |
|--|-------------|--------------------------|-----|--|-----------------------|-----------------|-------------------------|-----------------------|----------|
| 10.25x20.38x21.62 | 256x510x537 | 24 | 610 | TB/MTB93030 TB/MTB93060 TB/MTB93080 | 4.75 | 2.1 | SS2NC | | |
| 10.25x14x17.13 | 256x355x430 | 21 | 530 | TB/MTB92035 TB/MTB92060 TB/MTB92080 | 3.5 | 1.5 | SS3NC | | |
| 10.25x25.13x17.13 | 256x630x430 | 21 | 530 | TB/MTB93030* TB/MTB93060* TB/MTB93080* | 4 | 1.8 | SS4NC | | |

*Fits SS4NC with box turned sideways.*Not adaptable to 24" (610mm) long shelf.

See pages 92-93 for tote boxes.

Super Erecta Slide System in place on shelf (Tote box sold separately)

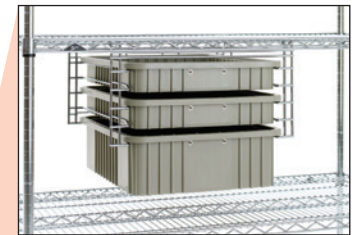



Super Erecta Slide Shelf Spacing Guide

Tote box combinations per slide

| 13" Shelf Spacing (330mm) | 16" Shelf Spacing (406mm) | 18" Shelf Spacing (457mm) |
|---------------------------|---------------------------|---------------------------|
| 3" (75mm) | 3" (75mm) | 3" (75mm) |
| 6" (152mm) | 3" (75mm) | 3" (75mm) |
| 3" (75mm) | 6" (152mm) | 8" (203mm) |
| 6" (152mm) | 6" (152mm) | 6" (152mm) |
| | 8" (203mm) | 8" (203mm) |

Adjustable Undershelf Slides — {10.04}

These slides can be spaced to fit any width container or tote box.

| Item | Approx. Pkd. Wt. (lbs.) | Approx. Pkd. Wt. (kg) | Cat. No. (pair) |
|----------------------------|-------------------------|-----------------------|-----------------|
| For 18" (457mm) wide shelf | 1 | 0.4 | US18NA |
| For 21" (530mm) wide shelf | 1 | 0.4 | US21NA |
| For 24" (610mm) wide shelf | 1 | 0.4 | US24NA |



Adjustable Undershelf Slide

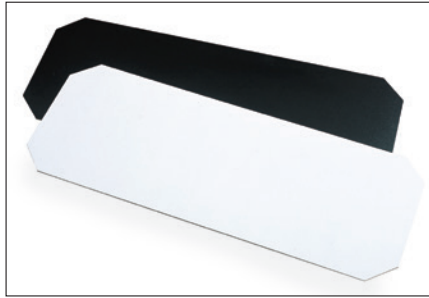

Decorator Shelf Inlays

Decorator Shelf Inlays — {10.06}

Hardboard mats prevent small items from falling through wire shelves. Fit between posts and level with top of shelf edge. Reversible, black and white. Packed individually.

| Width/Length (in.) (mm) | | Cat. No. |
|----------------------------|----------|----------|
| 14x36 | 355x914 | 1436BWI |
| 14x48 | 355x1219 | 1448BWI |
| 18x24 | 457x610 | 1824BWI |
| 18x36 | 457x914 | 1836BWI |
| 18x48 | 457x1219 | 1848BWI |
| 24x24 | 610x610 | 2424BWI |
| 24x36 | 610x914 | 2436BWI |
| 24x48 | 610x1219 | 2448BWI |



Clear Shelf Inlays

Clear Shelf Inlays — {10.06}

Nearly invisible plastic mat retains open-wire look of shelves and allows light penetration. Sold in packages of 4.

| Width/Length (in.) (mm) | | | Cat. No. | Width/Length (in.) (mm) | | | Cat. No. |
|----------------------------|----------|----------|----------|----------------------------|----------|----------|----------|
| 14x36 | 355x914 | 1436CI-4 | | 21x36 | 530x914 | 2136CI-4 | |
| 14x48 | 355x1219 | 1448CI-4 | | 21x48 | 530x1219 | 2148CI-4 | |
| 14x60 | 355x1524 | 1460CI-4 | | 21x60 | 530x1524 | 2160CI-4 | |
| 18x36 | 457x914 | 1836CI-4 | | 24x36 | 610x914 | 2436CI-4 | |
| 18x48 | 457x1219 | 1848CI-4 | | 24x48 | 610x1219 | 2448CI-4 | |
| 18x60 | 457x1524 | 1860CI-4 | | 24x60 | 610x1524 | 2460CI-4 | |

Garment Hanger Tube with Brackets — {10.05}

Hanger tubes attach easily under Super Erecta shelves for hanging garments. Available in 18," 21" and 24" (457, 530 and 610mm) widths and in same length as shelves.

| Tube Length (in.) (mm) | | Approx. Pkd. Wt. (lbs.) (kg) | | Shelf Width 18" (457mm) | Shelf Width 21" (530mm) | Shelf Width 24" (610mm) |
|---------------------------|------|---------------------------------|-----|----------------------------|----------------------------|----------------------------|
| 24 | 610 | 2.50 | 1.1 | AT2418NC | AT2421NC | AT2424NC |
| 30 | 760 | 2.50 | 1.1 | AT3018NC | AT3021NC | AT3024NC |
| 36 | 914 | 3 | 1.4 | AT3618NC | AT3621NC | AT3624NC |
| 42 | 1066 | 3.50 | 1.6 | AT4218NC | AT4221NC | AT4224NC |
| 48 | 1219 | 3.50 | 1.6 | AT4818NC | AT4821NC | AT4824NC |
| 60 | 1524 | 4 | 1.8 | AT6018NC | AT6021NC | AT6024NC |
| 72 | 1828 | 4.50 | 2.0 | AT7218NC | AT7221NC | AT7224NC |

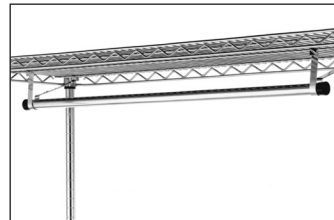

Garment Hanger Tube with Brackets



Large Display/Storage Basket

Storage Baskets — {10.05}

Generous-sized baskets attach in seconds to hanger rail or shelves.

| Width/Length/Depth (in.) (mm) | | Approx. Pkd. Wt. (lbs.) (kg) | | Cat. No. Plated | Cat. No. Black | Cat. No. White | Cat. No. Smoked Glass |
|----------------------------------|-------------|---------------------------------|---|-----------------|----------------|----------------|-----------------------|
| 13.37x5x7 | 345x127x180 | 8.5 | 4 | H209C | H209B | H209W | H209-DSG |
| 17.37x7.5x5 | 440x190x127 | 7 | 3 | H210C | H210B | H210W | H210-DSG |
| 17.37x7.5x10 | 440x190x255 | 11 | 5 | H212C | H212B | H212W | H212-DSG |



File Basket

File Basket — {10.05}

The convenient place to keep files and papers.

- Measures 2.62"W x 12.75" L x 8.75" H (67mm W x 324mm L x 222mm H).
- Large enough to hold standard-size file folders.
- Attaches easily.

| Width/Length (in.) (mm) | | Height (in.) (mm) | | Approx. Pkd. Wt. (lbs.) (kg) | | Cat. No. |
|----------------------------|--------|----------------------|-----|---------------------------------|-----|----------|
| 2.62x12.75 | 63x330 | 8.75 | 228 | 2.1 | 1.0 | PH1239C |



Hanger Rail

Hanger Rails — {10.05}

Convenient rail fits on posts along the width or length of the unit. Optional hooks can hang from rail at any point.

| Length† (in.) (mm) | Approx. Pkd. Wt. (lbs.) (kg) | Cat. No. Chrome | Cat. No. Black | Cat. No. White | Cat. No. Smoked Glass | Cat. No. Copper Hammertone | | |
|-----------------------|---------------------------------|-----------------|----------------|----------------|-----------------------|----------------------------|----------|----------|
| | | | | | | | 14 | 355 |
| 18 | 457 | 1.25 | .57 | H118C | H118B | H118W | H118-DSG | H118-DCH |
| 24 | 610 | 1.5 | .68 | H124C | H124B | H124W | H124-DSG | H124-DCH |
| 30 | 760 | 1.5 | .68 | H130C | H130B | H130W | H130-DSG | H130-DCH |
| 36 | 914 | 2 | .90 | H136C | H136B | H136W | H136-DSG | H136-DCH |
| 48 | 1219 | 2.5 | 1.13 | H148C | H148B | H148W | H148-DSG | H148-DCH |

†14", 18" and 24" (355, 457 and 610mm) sizes fit shelf width (depth). 30", 36" and 48" (760, 914 and 1219mm) sizes fit shelf length.



Extension Display Hanger

Extension Display Hanger — {10.06}

Snaps on Super Erecta Shelf hanger rails and shelf frames. Accepts standard carded merchandise.

| Length (in.) (mm) | Approx. Pkd. Wt. (lbs.) (kg) | Finish/Color* | | Cat. No. | |
|----------------------|---------------------------------|---------------|-----|----------|-------|
| | | 6 | 152 | | .25 |
| 6 | 152 | .25 | .1 | Black | HHK6B |
| 8 | 203 | .25 | .1 | Chrome | HHK8C |
| 8 | 203 | .25 | .1 | Black | HHK8B |

*White, smoked glass and copper hammertone also available. 4-6 week lead time. Contact your Metro representative.

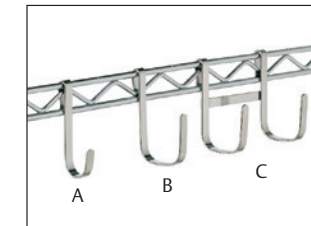

Snap-on Hooks

Snap-On Hooks — {10.05}

Multi-purpose hooks in three styles attach to hanger rails, mounting rails or shelves for instant access.

| Description | Height (in.) (mm) | | Cat. No. Chrome | Cat. No. Black |
|------------------|----------------------|----|-----------------|----------------|
| Style A — Small | 3.44 | 90 | HK23C | HK23B |
| Style B — Large | 3.44 | 90 | HK25C | HK25B |
| Style C — Double | 3.44 | 90 | HK26C | |



Swing Hanger

Swing Hanger — {10.05}

Attaches to post to provide convenient storage for hanging items. Epoxy finish.

| Arm Length (in.) (mm) | Weight Capacity (lbs.) (kg) | Cat. No. |
|--------------------------|--------------------------------|----------|
| 6.25 160 | 20 9 | H110BL |

SHELVING AND CART COVERS



21X48X54UCMB
(shown in Mariner Blue)

Shelving and Cart Covers — {11.80}

- Help protect contents from dust and other airborne contaminants.
- This allows units to be loaded and stored for longer periods of time before being transported. Covers also deter pilferage.
- Reinforced corners help prevent tears and add greatly to durability of covers.
- Choice of closure: Available in hook/loop or heavy-duty nylon zipper

Uncoated — machine washable:

- White: Knitted polyester, 4 oz. per square yard
- Mariner Blue: Woven polyester, 3.2 oz. per square yard.

Coated — waterproof, perfect for indoor/outdoor use:

- White or Mariner Blue — vinyl-coated nylon, 10 oz. per square yard
- Specially treated to resist bacteria, odor, mildew and flames

Catalog Numbers shown are for white cover. Add "MB" suffix to order Mariner Blue (i.e. 21X48X54UCMB)

| Length/Height (in.) | Length/Height (mm) | White Nylon Uncoated | | White Vinyl Coated | |
|--|-----------------------|------------------------------|----------------------------|------------------------------|----------------------------|
| | | Zippered Closure Cat. No. | Velcro Closure Cat. No. | Zippered Closure Cat. No. | Velcro Closure Cat. No. |
| FOR SHELF TRUCKS & CARTS 18" (457mm) DEEP | | | | | |
| 36x54 | 914x1370 | 18X36X54UC | 18X36X54VUC | 18X36X54C | 18X36X54VC |
| 36x62 | 914x1550 | 18X36X62UC | 18X36X62VUC | 18X36X62C | 18X36X62VC |
| 48x54 | 1219x1370 | 18X48X54UC | 18X48X54VUC | 18X48X54C | 18X48X54VC |
| 48x62 | 1219x1550 | 18X48X62UC | 18X48X62VUC | 18X48X62C | 18X48X62VC |
| 60x54 | 1524x1370 | 18X60X54UC | 18X60X54VUC | 18X60X54C | 18X60X54VC |
| 60x62 | 1524x1550 | 18X60X62UC | 18X60X62VUC | 18X60X62C | 18X60X62VC |
| FOR SHELF TRUCKS & CARTS 21" (530mm) DEEP | | | | | |
| 48x54 | 1219x1370 | 21X48X54UC | 21X48X54VUC | 21X48X54C | 21X48X54VC |
| 48x62 | 1219x1550 | 21X48X62UC | 21X48X62VUC | 21X48X62C | 21X48X62VC |
| 48x74 | 1219x1850 | 21X48X74UC | 21X48X74VUC | 21X48X74C | 21X48X74VC |
| 60x54 | 1524x1370 | 21X60X54UC | 21X60X54VUC | 21X60X54C | 21X60X54VC |
| 60x62 | 1524x1550 | 21X60X62UC | 21X60X62VUC | 21X60X62C | 21X60X62VC |
| 60x74 | 1524x1850 | 21X60X74UC | 21X60X74VUC | 21X60X74C | 21X60X74VC |
| FOR SHELF TRUCKS & CARTS 24" (610mm) DEEP | | | | | |
| 36x54 | 914x1370 | 24X36X54UC | 24X36X54VUC | 24X36X54C | 24X36X54VC |
| 36x62 | 914x1550 | 24X36X62UC | 24X36X62VUC | 24X36X62C | 24X36X62VC |
| 36x74 | 914x1850 | 24X36X74UC | 24X36X74VUC | 24X36X74C | 24X36X74VC |
| 48x54 | 1219x1370 | 24X48X54UC | 24X48X54VUC | 24X48X54C | 24X48X54VC |
| 48x62 | 1219x1550 | 24X48X62UC | 24X48X62VUC | 24X48X62C | 24X48X62VC |
| 48x74 | 1219x1850 | 24X48X74UC | 24X48X74VUC | 24X48X74C | 24X48X74VC |
| 60x54 | 1524x1370 | 24X60X54UC | 24X60X54VUC | 24X60X54C | 24X60X54VC |
| 60x62 | 1524x1550 | 24X60X62UC | 24X60X62VUC | 24X60X62C | 24X60X62VC |
| 60x74 | 1524x1850 | 24X60X74UC | 24X60X74VUC | 24X60X74C | 24X60X74VC |
| 72x54 | 1825x1370 | 24X72X54UC | 24X72X54VUC | 24X72X54C | 24X72X54VC |
| 72x62 | 1825x1550 | 24X72X62UC | 24X72X62VUC | 24X72X62C | 24X72X62VC |
| 72x74 | 1825x1850 | 24X72X74UC | 24X72X74VUC | 24X72X74C | 24X72X74VC |

*Cart covers are non-returnable.
Note: 86" (2185mm) high covers, in 24" (610mm) depth, available by special order.



Clear Vinyl
Cart Cover

Clear Vinyl Cart Covers

- Allows visual access while protecting shelf contents from dust and other airborne contaminants.
- Vinyl construction with Velcro closures.
- Available for 18" x 36" (457 x 914mm) shelving.

| Length/Height (in.) | Length/Height (mm) | Cat. No. |
|------------------------|-----------------------|----------|
| 36x32 | 914x889 | GWCVC41 |
| 36x52 | 914x1320 | GWCVC62 |

Indicates antimicrobial product.



Keyboard Tray — {10.06}

Attaches to all Metro wire shelves, 36" (914mm) length or longer. Mouse Tray adapts to left or right of Keyboard Tray. Flip-top compartment provides convenient storage. Constructed of durable high-impact polystyrene. Assembles easily.

- Hardware included for attachment to Metro wire shelves; template provided for attachment to solid desk surfaces.
 - Keyboard Tray Dimensions: 22" L (559mm) x 15.5" W (394mm).
 - Dimension with Mouse Tray fully extended: 29.5" L (749mm) x 15.5" W (394mm).
- Cat. No. CKS1522BL



Keyboard Tray

Wire Management Clip — {10.06}

Keeps wires and cables neatly organized both horizontally and vertically. Easily snaps over the edge of any Super Erecta wire or qwikSLOT shelf. Black epoxy finish.

| Width (in.) | Width (mm) | Length (in.) | Length (mm) | Approx. Pkd. Wt. (lbs.) | Approx. Pkd. Wt. (kg) | Cat. No. |
|----------------|---------------|-----------------|----------------|-------------------------------|-----------------------------|----------|
| 2 | 51 | 2 | 51 | .5 | .25 | CWM |



Wire Management Clip

Power Strip — {10.06}

- Mounts quickly and easily to either a Super Erecta or qwikSLOT post.
- Includes a 15 foot (4572mm) long cord.
- Mounting brackets and hardware included.
- UL/CSA approved.
- 15 Amp Circuit Breaker.
- Illuminated Power Switch. 15A/125VAC.60Hz/1875 W.
- Gray/blue finish.
- 14/3 SJT Molded Power Supply Cord.

| Width (in.) | Width (mm) | Length (in.) | Length (mm) | Approx. Pkd. Wt. (lbs.) | Approx. Pkd. Wt. (kg) | Cat. No. |
|----------------|---------------|-----------------|----------------|-------------------------------|-----------------------------|----------|
| 1.5 | 38 | 48 | 1219 | 6 | 2.72 | CPS48 |

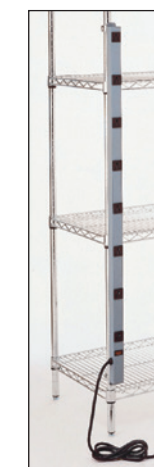

Power Strip

Surface Mount Swing Arm for Flat Monitor — {10.06}

- Range: Vertical, 15.9" (404mm); Horizontal 24.25" (613mm)
- Vertical Rotation: 360 degrees at three joints
- Monitor tilt: 200 degrees
- Monitor pivot: landscape to portrait
- Compatibility: VESA® 75mm and 100mm
- Cable management: Cables are concealed in arm
- Maximum weight load: 27.5 lbs. (12.5kg)

Cat. No. LTFMA

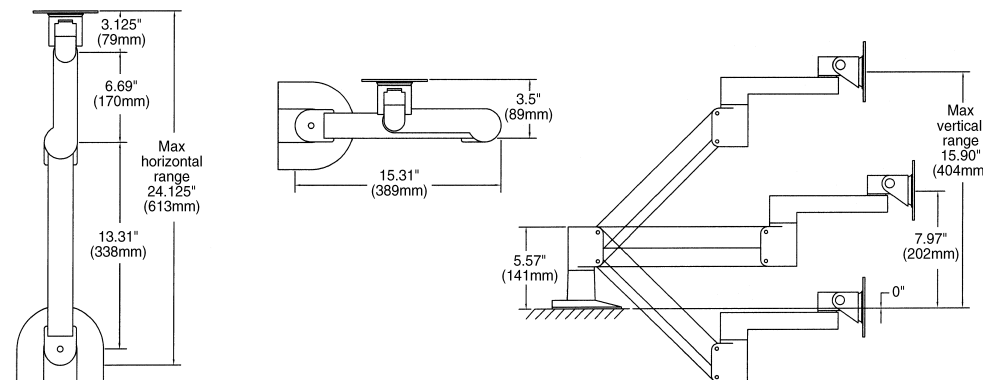



Perfect for applications involving spillage. Provides barrier between floor and bottom shelf contents to deter contamination.



Flat Solid Stainless Shelves with black epoxy-coated corners

Super Erecta® Solid Shelving — {10.20}

Features a 0.12" (3.2mm) raised "ship's edge" on all four sides to contain spills. Louvered/embossed shelf allows air circulation. Available in several styles and materials for a variety of applications. Shelves are constructed with 18-gauge stainless steel (Type 304) or galvanized materials.

Galvanized shelves with uncoated cast corners

Ideal for applications requiring a solid shelving or work surface and minimum resistance to corrosion. Available in flat solid and louvered/embossed styles.

Standard Stainless Steel solid shelves

(Type 304) with epoxy-coated cast corners address the majority of applications for solid, corrosion resistant shelves or work surfaces. Available in flat solid and louvered/embossed styles.

Premium Autoclave/Cart Washable Stainless Steel Solid Shelves (Type 304) feature an all-stainless construction to withstand high temperature, corrosive applications. Available in flat solid style.

| Width/Length (in) (mm) | GALVANIZED | | STAINLESS STEEL | |
|---------------------------|---------------|----------------------------|-----------------|----------------------------|
| | Cat. No. Flat | Cat. No. Louvered/Embossed | Cat. No. Flat | Cat. No. Louvered/Embossed |
| 14x24 355x610 | 1424FG | 1424LG | 1424FS | 1424LS |
| 14x30 355x760 | 1430FG | 1430LG | 1430FS | 1430LS |
| 14x36 355x914 | 1436FG | 1436LG | 1436FS | 1436LS |
| 14x42 355x1066 | 1442FG | 1442LG | 1442FS | 1442LS |
| 14x48 355x1219 | 1448FG | 1448LG | 1448FS | 1448LS |
| 14x60 355x1524 | 1460FG | 1460LG | 1460FS | 1460LS |
| 18x24 457x610 | 1824FG | 1824LG | 1824FS | 1824LS |
| 18x30 457x760 | 1830FG | 1830LG | 1830FS | 1830LS |
| 18x36 457x914 | 1836FG | 1836LG | 1836FS | 1836LS |
| 18x42 457x1066 | 1842FG | 1842LG | 1842FS | 1842LS |
| 18x48 457x1219 | 1848FG | 1848LG | 1848FS | 1848LS |
| 18x54 457x1370 | 1854FG | - | 1854FS | - |
| 18x60 457x1524 | 1860FG | 1860LG | 1860FS | 1860LS |
| 18x72 457x1829 | 1872FG | - | 1872FS | - |
| 21x24 530x610 | 2124FG | 2124LG | 2124FS | 2124LS |
| 21x30 530x760 | 2130FG | 2130LG | 2130FS | 2130LS |
| 21x36 530x914 | 2136FG | 2136LG | 2136FS | 2136LS |
| 21x42 530x1066 | 2142FG | 2142LG | 2142FS | 2142LS |
| 21x48 530x1219 | 2148FG | 2148LG | 2148FS | 2148LS |
| 21x60 530x1524 | 2160FG | 2160LG | 2160FS | 2160LS |
| 24x24 610x610 | 2424FG | 2424LG | 2424FS | 2424LS |
| 24x30 610x760 | 2430FG | 2430LG | 2430FS | 2430LS |
| 24x36 610x914 | 2436FG | 2436LG | 2436FS | 2436LS |
| 24x42 610x1066 | 2442FG | 2442LG | 2442FS | 2442LS |
| 24x48 610x1219 | 2448FG | 2448LG | 2448FS | 2448LS |
| 24x54 610x1370 | 2454FG | - | 2454FS | - |
| 24x60 610x1524 | 2460FG | 2460LG | 2460FS | 2460LS |
| 24x72 610x1829 | 2472FG | - | 2472FS | - |

Note: Weight Capacity (evenly distributed load): Shelves 48" (1219mm) or less in length can hold up to 800 lbs. (363kg). 60" (1524mm) long shelves can hold up to 600 lbs. (272kg). 72" (1829mm) long shelves can hold up to 300 lbs. (136kg). For standard packaging, the number of shelves per box varies by size. 14"/18" (355/457mm) wide solid shelving: less than 60" (1524mm) long (no more than 4 per carton); 60" (1524mm) long (no more than 2 per carton); 21" (530mm) wide solid shelving: less than 42" (1066mm) long (no more than 4 per carton); 42" (1066mm) or longer (no more than 2 per carton); 24" (610mm) wide solid shelving: 24", 30" (610, 760mm) long (no more than 4 per carton); 36" (914mm) or longer (no more than 2 per carton).



Autoclavable/Cart-Washable Solid Stainless Shelving

All-stainless construction to address autoclave and cart washing applications.

| Width/Length (in.) (mm) | | Approx. Pkd. Wt. per Shelf (lbs.) (kg) | | Cat. No. Autoclavable Stainless |
|----------------------------|---------|--|--|---------------------------------------|
| 14x24 355x610 | 10 4.5 | 1424NFS | | |
| 14x30 355x760 | 12 5.4 | 1430NFS | | |
| 14x36 355x914 | 14 6.4 | 1436NFS | | |
| 14x42 355x1066 | 15 6.8 | 1442NFS | | |
| 14x48 355x1219 | 17 7.7 | 1448NFS | | |
| 14x60 355x1524 | 22 9.9 | 1460NFS | | |
| 18x24 457x610 | 11 5.0 | 1824NFS | | |
| 18x30 457x760 | 14 6.4 | 1830NFS | | |
| 18x36 457x914 | 16 7.3 | 1836NFS | | |
| 18x42 457x1066 | 18 8.2 | 1842NFS | | |
| 18x48 457x1219 | 20 9.1 | 1848NFS | | |
| 18x60 457x1524 | 24 10.9 | 1860NFS | | |

| Width/Length (in.) (mm) | | Approx. Pkd. Wt. per Shelf (lbs.) (kg) | | Cat. No. Autoclavable Stainless |
|----------------------------|---------|--|--|---------------------------------------|
| 21x24 530x610 | 13 5.9 | 2124NFS | | |
| 21x30 530x760 | 15 6.8 | 2130NFS | | |
| 21x36 530x914 | 18 8.2 | 2136NFS | | |
| 21x42 530x1066 | 21 9.5 | 2142NFS | | |
| 21x48 530x1219 | 23 10.4 | 2148NFS | | |
| 21x60 530x1524 | 26 11.8 | 2160NFS | | |
| 24x24 610x610 | 15 6.8 | 2424NFS | | |
| 24x30 610x760 | 17 7.7 | 2430NFS | | |
| 24x36 610x914 | 19 8.6 | 2436NFS | | |
| 24x42 610x1066 | 21 9.5 | 2442NFS | | |
| 24x48 610x1219 | 24 10.9 | 2448NFS | | |
| 24x60 610x1524 | 31 14.0 | 2460NFS | | |

Metro Tip:
Order aluminum split sleeves with stainless C-rings for corrosive, high-temperature autoclave or cart washing applications. (Cat. No. 9986S, one bag required per shelf).



SiteSelect™ Posts are grooved at 1" (25mm) increments and numbered at 2" (50mm) increments. Posts are double-grooved every 8" (203mm) for easy identification.

SiteSelect® Posts for Super Erecta® Solid Shelving — {10.20}

Stationary posts are fitted with adjustable leveling bolts to compensate for uneven surfaces. Mobile posts come without leveling bolt to accommodate stem casters. Special length posts are available.†

| Height* (in.) (mm) | Approx. Pkd. Wt. (lbs.) (kg) | Cat. No. Chrome Stationary | Cat. No. Chrome Mobile | Cat. No. Cart Wash/Autoclave | Cat. No. Stainless Stationary** | Cat. No. Stainless Mobile |
|-----------------------|---------------------------------|----------------------------|------------------------|------------------------------|---------------------------------|---------------------------|
| 7.5 191 | .5 0.3 | 7P | 7UP | - | - | - |
| 14.5 370 | 1 0.5 | 13P | 13UP | - | 13PS | 13UPS |
| 27.5 699 | 1.75 0.75 | 27P | 27UP | - | 27PS | 27UPS |
| 34.5 875 | 2 0.9 | 33P | 33UP | 33UPS-SW | 33PS | 33UPS |
| 54.56 1385 | 3 1.4 | 54P | 54UP | 54UPS-SW | 54PS | 54UPS |
| 62.56 1590 | 3.5 1.6 | 63P | 63UP | 63UPS-SW | 63PS | 63UPS |
| 74.62 1895 | 4 1.8 | 74P | 74UP | - | 74PS | 74UPS |
| 86.62 2200 | 5 2.3 | 86P | 86UP | - | 86PS | 86UPS |
| 96.62 2454 | 5.5 2.5 | ***96P | - | - | - | - |

†Note: Special length posts are available, priced at next higher length plus a cutting charge. Post lengths to be specified as cut to a round number, ie: 74P cut to 69" (1753mm). This will result in an overall post height with adjustment of 69.37" (1762mm) to 69.87" (1775mm).
*Height includes leveling bolt and cap.
**Stainless stationary post includes stainless leveling bolt.
***96P should not be used on units less than 24" (610mm) deep. Consult Metro Engineering for alternate recommendations.

Super Erecta® Counter Units — {10.35}

To create a counter unit, select the following components:

- 2 each — 14" (355mm) deep upper shelves, (see page 74)
- 2 each — 24" (610mm) deep lower shelves, (see page 74)
- 2 each — upper front posts, listed below
- 2 each — lower front posts, listed below
- 2 each — 63" (1600mm) or 74" (1880mm) high back posts (listed above).

Special Posts For Counter Units — {10.35}

| Unit | Unit Height (in.) (mm) | Post Height* (in.) (mm) | Approx. Pkd. Wt. (lbs.) (kg) | Cat. No. Plated | Cat. No. Stainless |
|-------------------|---------------------------|----------------------------|---------------------------------|-----------------|--------------------|
| Upper Front Posts | 63 1600 | 28.62 727 | 1 1/2 0.7 | 27PF | 27PFS |
| | 74 1880 | 40.62 1032 | 2 0.9 | 39PF | 39PFS |
| Lower Front Posts | All Heights | 34.5 877 | 2 0.9 | 33PM | 33PMS |

*Height includes leveling bolt and cap.



Counter Unit with galvanized shelves.



Chrome ledges with plated steel clips



Stainless ledge with polymer clip



Rods with Tab in place



Shelf Dividers



Joining Clamp



Adjustable Undershelf Slides

Shelf Ledges for Solid Shelves — {10.25}

Sturdy 4" (101mm) ledges contain items on shelves. Spring-clip tabs included for attachment.

Note: ledges are not stackable.

| Fits Shelf Length (in.) (mm) | Cat. No. Plated | Cat. No. Stainless |
|------------------------------|-----------------|--------------------|
| 14 355 | L14WC | L14WS |
| 18 457 | L18WC | L18WS |
| 21 530 | L21WC | L21WS |
| 24 610 | L24WC | L24WS |
| 30 760 | L30WC | L30WS |
| 36 914 | L36WC | L36WS |
| 42 1066 | L42WC | L42WS |
| 48 1219 | L48WC | L48WS |
| 60 1524 | L60WC | L60WS |

*Actual ledge length is approximately 1" (25mm) shorter than nominal shelf length/width. Standard spring-clip tabs are plated steel.



Chrome Plated Ledge Clip
6 Per Bag
Cat. No. 9184Z



Polymer Ledge Clip for use with stainless steel ledges
6 Per Bag
Cat. No. 9184P



Additional Tabs
Bag of 6
Cat. No. 9184Z
Note: Standard tabs are plated steel

For applications requiring a corrosion proof solution, consult your Metro representative.

Rods and Tabs for Solid Shelves — {10.25}

Create a more versatile system by enclosing sides and back of an entire unit. Tabs required to attach rods to a 4-shelf unit are supplied. Additional tabs also available in bags of 6.

| Min. Post Height (in.) | Rod Length (in.) (mm) | Approx. Pkd. Wt. (lbs.) (kg) | Cat. No. Plated |
|------------------------|-----------------------|------------------------------|-----------------|
| 54 | 52 1320 | 1 0.5 | R52FC |
| 63 | 60 1524 | 1 0.5 | R60FC |
| 74 | 72 1830 | 1.25 0.6 | R72FC |
| 86 | 84 2135 | 1.5 0.7 | R84FC |

Note: Standard spring-clip tabs are plated steel.

Shelf Dividers — {10.25}

The easy way to keep shelves orderly. 8" (203mm) high dividers attach with provided spring clips.

| Length (in.) (mm) | Approx. Pkd. Wt. Per 6 Pieces (lbs.) (kg) | Cat. No. Plated | Cat. No. Stainless |
|-------------------|---|-----------------|--------------------|
| 14 355 | 12 5.4 | DD14FC | |
| 18 457 | 13.5 6.0 | DD18FC | DD18FS |
| 21 530 | 15 6.8 | DD21FC | |
| 24 610 | 16.5 7.4 | DD24FC | DD24FS |

Solid Shelf Joining Clamp — {10.25}

Save time and money by eliminating adjacent posts and replacing with solid shelf joining clamps. Join units end-to-end, back-to-back or at right angles. Two clamps required per shelf to attach to adjacent units. Zinc. **Cat. No. 9998Z**

Note: Shelves with joining clamps can only be attached to shelves supported by two or more posts.

Adjustable Undershelf Slides — {10.25}

Create a convenient drawer system by combining a tote box with these slides. Two slides are required, and can be spaced to fit any width container.

| Item | Approx. Pkd. Wt. (lbs.) (kg) | Cat. No. Solid |
|----------------------------|------------------------------|----------------|
| For 18" (457mm) wide shelf | 1 0.4 | US18FA |
| For 21" (530mm) wide shelf | 1 0.4 | US21FA |
| For 24" (610mm) wide shelf | 1 0.4 | US24FA |

For application-specific totes, refer to index.



Erecta Shelf® Shelving

This easy-to-assemble system puts space to work practically anywhere.

- Units go together without tools — shelf grooves simply lock into uprights at 5" (127mm) increments.
- Accessories create a truly versatile system.



Erecta Shelf® Uprights — {10.50}

| Width/Length (in.) (mm) | Approx. Pkd. Wt. (lbs.) (kg) | Cat. No. Chrome |
|-------------------------|------------------------------|-----------------|
| 12x53.5 305x1359 | 7 3.2 | 1252C |
| 12x63.5 305x1613 | 8 3.3 | 1262C |
| 12x73.5 305x1867 | 9 4.1 | 1272C |
| 12x88.5 305x2248 | 11 5.0 | 1287C |
| 18x53.5 457x1359 | 8 3.3 | 1852C |
| 18x63.5 457x1613 | 9 4.1 | 1862C |
| 18x73.5 457x1867 | 11 5.0 | 1872C |
| 18x88.5 457x2248 | 13.5 6.2 | 1887C |

Packaging: 6 uprights to a carton.

Erecta Shelf® Wire Shelves — {10.50}

| Width/Length (in.) (mm) | Approx. Pkd. Wt. (lbs.) (kg) | Cat. No. Chrome |
|-------------------------|------------------------------|-----------------|
| 12x24 305x610 | 5 2.2 | 1224C |
| 12x30 305x760 | 6 2.7 | 1230C |
| 12x36 305x914 | 7 3.1 | 1236C |
| 12x42 305x1066 | 8.25 3.7 | 1242C |
| 12x48 305x1219 | 9.5 4.2 | 1248C |
| 12x60 305x1524 | 12 5.4 | 1260C |
| 18x24 457x610 | 6.5 2.9 | 1824C |
| 18x30 457x760 | 8 3.6 | 1830C |
| 18x36 457x914 | 10 4.5 | 1836C |
| 18x42 457x1066 | 11 4.9 | 1842C |
| 18x48 457x1219 | 12.5 5.6 | 1848C |
| 18x60 457x1524 | 16 7.2 | 1860C |

Load Rating: Shelves up to 48" Long – 800 lbs. (363 kg) equally distributed.
Shelves 60" Long – 600 lbs. (277 kg) equally distributed.
Maximum – 2000 lbs. (907 kg) per 4 shelf unit

Shelf Dividers

Keep shelves orderly with these snap-in-place, 8" (203mm) high dividers.

| Shelf Width (in.) (mm) | Approx. Pkd. Wt. Per 6 Pieces (lbs.) (kg) | Cat. No. Plated |
|------------------------|---|-----------------|
| 12 305 | 12 5.4 | DD12C |
| 18 457 | 13.5 6.1 | DD18C |
| 24 610 | 16.5 7.4 | DD24C |

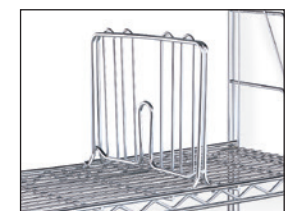

Shelf Divider



HD Super Solid Stainless Shelving with black epoxy-coated corners

HD Super™ Solid Stainless Shelving

Heavy-duty system features 16-gauge solid shelves.

- Large 1.62" (41mm) diameter posts and 2" (51mm) shelf adjustability.

HD Super Flat Shelves — {10.65}

| Width/Length (in.) | Width/Length (mm) | Approx. Pkd. Wt. (lbs.) (kg) | | Cat. No. Stainless |
|--------------------|-------------------|------------------------------|------|--------------------|
| 18x36 | 457x914 | 21 | 9.5 | 1836HFS |
| 18x42 | 457x1066 | 23 | 10.4 | 1842HFS |
| 18x48 | 457x1219 | 26 | 11.7 | 1848HFS |
| 18x54 | 457x1370 | 28 | 12.7 | 1854HFS |
| 18x60 | 457x1524 | 31 | 14.0 | 1860HFS |
| 24x36 | 610x914 | 25 | 11.3 | 2436HFS |
| 24x42 | 610x1066 | 29 | 13.1 | 2442HFS |
| 24x48 | 610x1219 | 32 | 14.4 | 2448HFS |
| 24x54 | 610x1370 | 35 | 15.8 | 2454HFS |
| 24x60 | 610x1524 | 38 | 17.1 | 2460HFS |

Load Ratings: Shelf: 1,000 lbs. (454kg) evenly distributed per shelf, not to exceed unit load rating. Stationary Unit: 3,000 lbs. (1363 kg.) evenly distributed. Mobile Unit: 1,000 lbs. (454 kg) with casters.

HD Super Stationary Posts — {10.65}

| Height* (in.) (mm) | Approx. Pkd. Wt. (lbs.) (kg) | Cat. No. Stainless |
|--------------------|------------------------------|--------------------|
| 56 1421 | 5.8 2.6 | 54HPS |
| 64 1624 | 6.3 2.9 | 63HPS |
| 76 1929 | 7.5 3.4 | 74HPS |

*Height includes leveling foot and cap. Special length posts are available. For more information, contact your Metro representative.
Packaging: 4 posts to a carton.

HD Super Stem Caster Posts — {10.65}

| Height (in.) (mm) | Approx. Pkd. Wt. (lbs.) (kg) | Cat. No. Stainless |
|-------------------|------------------------------|--------------------|
| 54.56 1386 | 5.7 2.5 | 54UHPS |
| 62.56 1590 | 6.3 2.8 | 63UHPS |
| 74.62 1894 | 7.5 3.3 | 74UHPS |

HD Super Stem Casters

Includes donut bumpers with each caster.

| Wheel Diameter (in.) (mm) | Face Diameter (in.) (mm) | Type | Wheel Tread | Cat. No. |
|---------------------------|--------------------------|--------|--------------|----------|
| 5 127 | 1.5 38.1 | Swivel | Polyurethane | 5HHP |
| 5 127 | 1.5 38.1 | Brake | Polyurethane | 5HHPB |

Load rating per caster: 400 lbs. (182kg).

HD Super shelves, posts, and casters are not compatible with Super Erecta or Super Adjustable Super Erecta components.

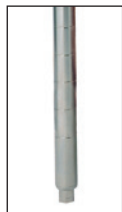

HD Super Post

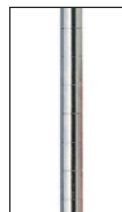

HD Super Stem Caster Post



HD Super Stem Caster

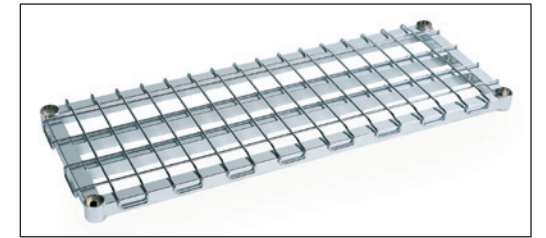

HD Super Dunnage Shelf

HD Super Dunnage Shelves — {10.67}

Static load capacity (uniformly distributed)

- 48" (1219mm) shelf: 3,000 lbs. (1361kg).
- 60" (1524mm) shelf: 2,400 lbs. (1089kg).
- For use on HD Super 1.62" (41mm) diameter posts only.
- Removable wire deck.

| Width/Length (in.) | Width/Length (mm) | Approx. Pkd. Wt. (lbs.) (kg) | | Cat. No. Chrome |
|--------------------|-------------------|------------------------------|------|-----------------|
| 18x48 | 457x1219 | 35 | 15.7 | 1848HDRC |
| 18x60 | 457x1524 | 43 | 19.3 | 1860HDRC |
| 24x48 | 610x1219 | 38 | 17.1 | 2448HDRC |
| 24x60 | 610x1524 | 47 | 21.1 | 2460HDRC |

Important: In stationary shelving, stability decreases as the ratio of height to width increases and when heavier loads are placed on upper shelves. Keep units as wide and low as possible, using the dunnage shelf as the bottom shelf. If two dunnage shelves are being used, both should be placed within the lower half of the unit.
Note: Not compatible with Super Erecta or Super Adjustable Super Erecta components.

HD Super Cantilever Shelf — {10.67}

| Width/Length (in.) | Width/Length (mm) | Approx. Pkd. Wt. (lbs.) (kg) | | Cat. No. Stainless |
|--------------------|-------------------|------------------------------|-----|--------------------|
| 12x54 | 304x1372 | 11.8 | 5.3 | 1254CHS |
| 12x60 | 304x1524 | 12.7 | 5.7 | 1260CHS |

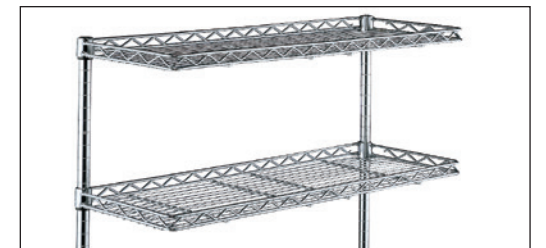

HD Super™ Cantilever Shelf

HD Super Replacement Parts — {10.65}

Replacement HD Super Aluminum Split Sleeves with Zinc Ring
4 pair per bag
Cat. No. 9986HZ



Replacement HD Super™ Aluminum Split Sleeve

Replacement HD Super Plastic Split Sleeves

4 pair per bag
Cat. No. 9985H



Replacement HD Super™ Plastic Split Sleeve

Post Clamps

Cat. No. 9994HZ



Post Clamp

Replacement 5.5" (140mm) Donut Bumpers

Fit 1.62" (41mm) posts only.
Cat. No. 9992H



Replacement 5.5" (140mm) Donut Bumper

3.5" (89mm) Foot Plates

Cat. No. 9993HS



3.5" (89mm) Foot Plate

Wall Mounting Brackets

(not shown)
Cat. No. 9984HZ

Indicates antimicrobial product.



Why qwikSLOT?



Add or remove a shelf with ease.



Perfect for retail & grocery.

Why Drop Mat?



Keeps items contained.

Shelves only 1/4" thick.

Save space with built in Ledge.



Super Erecta qwikSLOT shelving unit in black epoxy



qwikSLOT post with shelf clip



qwikSLOT Locking Clip
Recommended for mobile applications. Must be used with 9985QS shelf clips. (Package of 4)
Cat. No. 9985QSL



Replacement qwikSLOT Shelf Clips
(Package of 4)
Cat. No. 9985QS

qwikSLOT® Display Shelving System Set, reset in a flash.

Metro qwikSLOT shelves offer the quality of Super Erecta with the convenience of easily adjustable and removable shelves.

- Unique support system snaps into the posts, allowing instant shelf adjustment.
- Each unit requires a standard Super Erecta shelf at the top and bottom. (see page 48)

qwikSLOT® Shelves — {10.11}

| Width / Length (in.) | Width / Length (mm) | Chrome Cat. No. | Black Cat. No. | Smoked Glass Cat. No. | Copper Hammettone Cat. No. |
|----------------------|---------------------|-----------------|----------------|-----------------------|----------------------------|
| 14 x 36 | 355 910 | 1436QC | 1436QBL | 1436Q-DSG | 1436Q-DCH |
| 14 x 48 | 355 1220 | 1448QC | 1448QBL | 1448Q-DSG | 1448Q-DCH |
| 18 x 36 | 455 910 | 1836QC | 1836QBL | 1836Q-DSG | 1836Q-DCH |
| 18 x 48 | 455 1220 | 1848QC | 1848QBL | 1848Q-DSG | 1848Q-DCH |
| 18 x 60 | 455 1525 | 1860QC | - | - | - |
| 21 x 36 | 530 910 | 2136QC | 2136QBL | 2136Q-DSG | 2136Q-DCH |
| 21 x 48 | 530 1220 | 2148QC | 2148QBL | 2148Q-DSG | 2148Q-DCH |
| 21 x 60 | 530 1525 | 2160QC | - | - | - |
| 24 x 36 | 610 910 | 2436QC | 2436QBL | 2436Q-DSG | 2436Q-DCH |
| 24 x 48 | 610 1220 | 2448QC | 2448QBL | 2448Q-DSG | 2448Q-DCH |
| 24 x 60 | 610 1525 | 2460QC | - | - | - |

Note: A typical unit will incorporate 4 qwikSLOT posts, at least 2 Super Erecta shelves (one at the top and bottom of unit) and as many qwikSLOT shelves as desired between the top and bottom shelf. A three sided frame is recommended for increased rigidity.

Note: A qwikSLOT shelf is rated at 300 lbs. (135kg) per shelf. A typical qwikSLOT unit is rated at 800 lbs. (375kg) capacity per unit. For higher unit capacities, an intermediate standard Super Erecta shelf must be installed approximately at mid-height on the unit.

Note: Mobile Applications: All mobile applications require an intermediate standard Super Erecta shelf, installed approximately at mid-height on the unit. Mobile posts come without leveling bolt assembly to accommodate stem casters. The qwikSLOT lock clip (9985QSL) is recommended for mobile applications.

qwikSLOT® Posts — {10.11}

Clips snap into slots along the height of the post for shelf adjustment at 1" (25mm) intervals. Use for qwikSLOT shelving only.

Stationary

| Dimensions Height (in.) | Dimensions Height (mm) | Plated Cat. No. | Black Cat. No. | Smoked Glass Cat. No. | Copper Hammettone Cat. No. |
|-------------------------|------------------------|-----------------|----------------|-----------------------|----------------------------|
| 34.5 | 875 | 33PQ | 33PQBL | 33PQ-DSG | 33PQ-DCH |
| 54.56 | 1385 | 54PQ | 54PQBL | 54PQ-DSG | 54PQ-DCH |
| 63.56 | 1590 | 63PQ | 63PQBL | 63PQ-DSG | 63PQ-DCH |
| 74.62 | 1895 | 74PQ | 74PQBL | 74PQ-DSG | 74PQ-DCH |
| 86.62 | 2200 | 86PQ | 86PQBL | 86PQ-DSG | 86PQ-DCH |

Note: Height includes leveling bolt and cap.

Mobile

| Dimensions Height (in.) | Dimensions Height (mm) | Plated Cat. No. | Black Cat. No. | Smoked Glass Cat. No. | Copper Hammettone Cat. No. |
|-------------------------|------------------------|-----------------|----------------|-----------------------|----------------------------|
| 34.87 | 875 | 33UPQ | 33UPQBL | 33UPQ-DSG | 33UPQ-DCH |
| 54 | 1385 | 54UPQ | 54UPQBL | 54UPQ-DSG | 54UPQ-DCH |
| 62 | 1590 | 63UPQ | 63UPQBL | 63UPQ-DSG | 63UPQ-DCH |
| 74 | 1895 | 74UPQ | 74UPQBL | 74UPQ-DSG | 74UPQ-DCH |
| 86 | 2200 | 86UPQ | 86UPQBL | 86UPQ-DSG | 86UPQ-DCH |

Note: Posts come without leveling bolt assembly to accommodate casters.

SET UP WITHIN GONDOLA STYLE SHELVING

1. Assemble your new Metro Display Shelving System (no tools required).
2. Remove upper shelves of your existing gondola unit. Do not remove the base shelf or kick panel.
3. Place your new Metro display shelving unit onto the gondola base shelf and slide into place.
Metro Tip: Order optional triangular foot plates to replace leveling bolts. Foot plates distribute heavy weight evenly.





Perfect for:

- Retail Display
- Lean “Two-Bin”

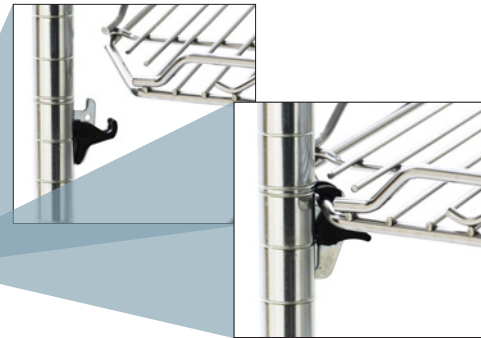

Metro® qwikSLOT Drop Mat Shelving



Metro® Super Erecta Drop Mat Shelving



Metro® qwikSLOT Drop Mat Shelving

Super Erecta Drop Mat & qwikSLOT Drop Mat — {10.12}

Built-in shelf ledge, approximately 1" (25mm) high, prevents contents from falling off shelf. Each shelf holds up to 250lbs (113kg), 800lbs. (375kg) per unit. Available in Super Erecta and qwikSLOT styles. Available in stationary or mobile.

- qwikSLOT® Drop Mat offers a built-in shelf ledge and the convenience of easily removing or adjusting without disturbing the shelves below or above.
- Shelves can be installed flat or at an angle. All shelves adjust in 1" increments.

Super Erecta Drop Mat Shelving — To be used with Super Erecta posts (see page 49)

| Width/Length (in.) | Width/Length (mm) | Approx. Pkd. Wt. (lbs.) | Approx. Pkd. Wt. (kg) | Cat. No. Chrome | Cat. No. Copper Hammeritone | Cat. No. Black | Cat. No. White | Cat. No. Smoked Glass |
|--------------------|-------------------|-------------------------|-----------------------|-----------------|-----------------------------|----------------|----------------|-----------------------|
| 14x36 | 355x914 | 7.25 | 3.2 | HDM1436QC | HDM1436-DCH | HDM1436BL | HDM1436W | HDM1436-DSG |
| 14x48 | 355x1219 | 9.75 | 4.3 | HDM1448QC | HDM1448-DCH | HDM1448BL | HDM1448W | HDM1448-DSG |
| 18x36 | 457x914 | 8.5 | 3.8 | HDM1836QC | HDM1836-DCH | HDM1836BL | HDM1836W | HDM1836-DSG |
| 18x48 | 457x1219 | 11.25 | 5.0 | HDM1848QC | HDM1848-DCH | HDM1848BL | HDM1848W | HDM1848-DSG |
| 21x36 | 530x914 | 10.75 | 4.8 | HDM2136QC | HDM2136-DCH | HDM2136BL | HDM2136W | HDM2136-DSG |
| 21x48 | 530x1219 | 13.25 | 5.9 | HDM2148QC | HDM2148-DCH | HDM2148BL | HDM2148W | HDM2148-DSG |
| 24x24 | 610x614 | 8.5 | 3.8 | HDM2424QC | HDM2424-DCH | HDM2424BL | HDM2424W | HDM2424-DSG |
| 24x36 | 610x914 | 12.25 | 5.5 | HDM2436QC | HDM2436-DCH | HDM2436BL | HDM2436W | HDM2436-DSG |
| 24x48 | 610x1219 | 15.25 | 6.8 | HDM2448QC | HDM2448-DCH | HDM2448BL | HDM2448W | HDM2448-DSG |



Mobile units require:

1. Standard Super Erecta, Drop Mat Super Erecta or 3-Sided Frame top, middle and bottom shelves for rigidity.



2. Locking Clips on all qwikSlot levels.



Stationary units require:

1. Standard Super Erecta top and bottom shelves for rigidity.



qwikSLOT Locking Clip
For mobile applications. To be used with qwikSLOT shelf clips. (Package of 4)
Cat. No. 9985QSL



Casters types available for all mobile applications.

| Wheel Diameter (in.) | Wheel Diameter (mm) | Type | Resilient Tread Cat. No. | Polyurethane Tread Cat. No. |
|----------------------|---------------------|--------------|--------------------------|-----------------------------|
| 5 | 32 | Swivel | 5M | 5MP |
| 5 | 132 | Swivel/Brake | 5MB | 5MPB |

qwikSLOT® Drop Mat Shelves — {10.12}

Increase storage capacity by as much as 30%. Each shelf holds up to 250 lbs (113kg). Shelves are easy to adjust and remove. Super Erecta or Super Erecta Drop Mat shelves are required at top and bottom. Use with qwikSLOT posts (See Page 81).

| Width/Length (in.) | Approx. Pkd. Wt. (lbs.) | Cat. No. Chrome | Cat. No. Black | Cat. No. Smoked Glass | Cat. No. Copper Hammeritone |
|--------------------|-------------------------|-----------------|----------------|-----------------------|-----------------------------|
| 14x36 | 7.25 | HDM1436QC | HDM1436QBL | HDM1436Q-DSG | HDM1436Q-DCH |
| 14x48 | 9.75 | HDM1448QC | HDM1448QBL | HDM1448Q-DSG | HDM1448Q-DCH |
| 18x36 | 8.5 | HDM1836QC | HDM1836QBL | HDM1836Q-DSG | HDM1836Q-DCH |
| 18x48 | 11.25 | HDM1848QC | HDM1848QBL | HDM1848Q-DSG | HDM1848Q-DCH |
| 21x36 | 10.75 | HDM2136QC | HDM2136QBL | HDM2136Q-DSG | HDM2136Q-DCH |
| 21x48 | 13.25 | HDM2148QC | HDM2148QBL | HDM2148Q-DSG | HDM2148Q-DCH |
| 24x36 | 12.25 | HDM2436QC | HDM2436QBL | HDM2436Q-DSG | HDM2436Q-DCH |
| 24x48 | 15.25 | HDM2448QC | HDM2448QBL | HDM2448Q-DSG | HDM2448Q-DCH |

qwikSLOT® Posts — {10.11}

Clips snap into slots along the post for shelf adjustment at 1" (25mm) intervals. Use for qwikSLOT shelving only.

| Dimensions (in.) | Height (mm) | Approx. Pkd. Wt. (lbs.) | Approx. Pkd. Wt. (kg) | Stationary | | | | Mobile | | | |
|------------------|-------------|-------------------------|-----------------------|-----------------|----------------|-----------------------|-----------------------------|-----------------|----------------|-----------------------|-----------------------------|
| | | | | Plated Cat. No. | Black Cat. No. | Smoked Glass Cat. No. | Copper Hammeritone Cat. No. | Plated Cat. No. | Black Cat. No. | Smoked Glass Cat. No. | Copper Hammeritone Cat. No. |
| 34.5 | 875 | 2 | 0.9 | 33PQ | 33PQBL | 33PQ-DSG | 33PQ-DCH | 33UPQ | 33UPQBL | 33UPQ-DSG | 33UPQ-DCH |
| 54.56 | 1385 | 3 | 1.4 | 54PQ | 54PQBL | 54PQ-DSG | 54PQ-DCH | 54UPQ | 54UPQBL | 54UPQ-DSG | 54UPQ-DCH |
| 63.56 | 1590 | 3.5 | 1.6 | 63PQ | 63PQBL | 63PQ-DSG | 63PQ-DCH | 63UPQ | 63UPQBL | 63UPQ-DSG | 63UPQ-DCH |
| 74.62 | 895 | 4 | 1.8 | 74PQ | 74PQBL | 74PQ-DSG | 74PQ-DCH | 74UPQ | 74UPQBL | 74UPQ-DSG | 74UPQ-DCH |
| 86.62 | 2200 | 5 | 2.3 | 86PQ | 86PQBL | 86PQ-DSG | 86PQ-DCH | 86UPQ | 86UPQBL | 86UPQ-DSG | 86UPQ-DCH |

Snap-On Dividers for Drop Mat Shelves — {10.04}

Organize your shelves with these 8" (203mm) high, easy to snap-in-place dividers.

| Fits Shelf Width (in.) | Fits Shelf Width (mm) | Approx. Pkd. Wt. (lbs.) | Approx. Pkd. Wt. (kg) | Cat. No. Plated | Cat. No. Black | Cat. No. White | Cat. No. Smoked Glass | Cat. No. Copper Hammeritone |
|------------------------|-----------------------|-------------------------|-----------------------|-----------------|----------------|----------------|-----------------------|-----------------------------|
| 18 | 457 | 2.5 | 1.1 | HD18C | HD18B | HD18W | HD18-DSG | HD18-CH |
| 24 | 614 | 3.5 | 1.6 | HD24C | HD24B | HD24W | HD24-DSG | HD24-CH |

*Refer to page 131 for information about Designer Colors.



Snap-On Divider



Quicker access with more versatility.

Metro® Super Erecta® basket shelves provide more options to our vast line of storage solutions.

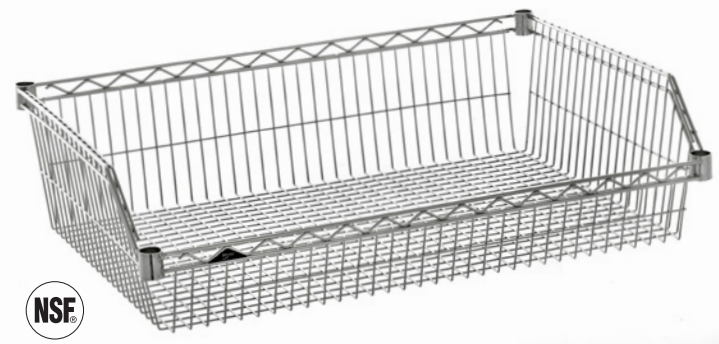

Super Erecta “Hopper-Style” Basket Shelving — {10.85}

This hopper-style basket shelving provides easier ability to load supplies and access them when needed without fear of losing product from falling behind the shelf. Add casters to maximize efficiency by making the whole unit mobile. Integrates seamlessly with Metro's line of Super Erecta shelving.

- Easier access to supplies.
- Front edge design protects supplies from rips and tears.
- Stays rigid and strong for mobile use.
- Compatible with Super Erecta shelving, carts and track shelving.
- Baskets nest for more compact shipping (packed 2 per box).
- 1" wire mesh spacing.

Baskets:

| Model No. | Length | | Width | | Basket Front Height | | Basket Back Height | |
|-----------|--------|------|-------|------|---------------------|------|--------------------|------|
| | (in.) | (mm) | (in.) | (mm) | (in.) | (mm) | (in.) | (mm) |
| BSK1824NC | 24 | 610 | 18 | 457 | 5 | 127 | 9 | 229 |
| BSK1836NC | 36 | 914 | 18 | 457 | 5 | 127 | 9 | 229 |
| BSK1848NC | 48 | 1219 | 18 | 457 | 5 | 127 | 9 | 229 |
| BSK1860NC | 60 | 1524 | 18 | 457 | 5 | 127 | 9 | 229 |
| BSK2424NC | 24 | 610 | 24 | 610 | 5 | 127 | 9 | 229 |
| BSK2436NC | 36 | 914 | 24 | 610 | 5 | 127 | 9 | 229 |
| BSK2448NC | 48 | 1219 | 24 | 610 | 5 | 127 | 9 | 229 |
| BSK2460NC | 60 | 1524 | 24 | 610 | 5 | 127 | 9 | 229 |



Baskets on Stationary Unit

Super Erecta “Hopper-Style” Basket Shelving Accessories — {10.85}



Casters
(See Page 58-59)



Posts
(See Page 49)

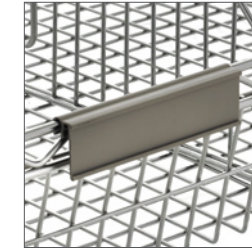

MetroMax Q Label Holders
MQ04LH (4") MQ48LH (48")
MQ24LH (24") MQ60LH (60")

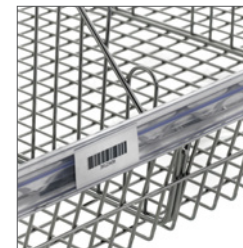

Full-Width Label Holders
QB18LHC (18")
QB36LHC (36")
QB48LHC (48")



Dividers
BSKDIV-18H (18")
BSKDIV-24H (24")

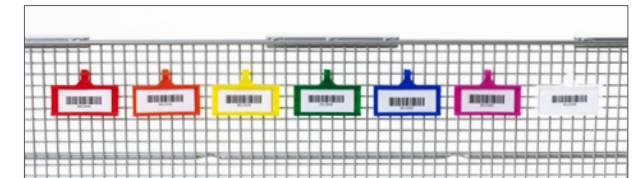

Colored Label Holder (shown with labels):
QB03LHRD - Red QB03LHOR - Orange QB03LHYL - Yellow
QB03LHGR - Green QB03LHBL - Blue QB03LHPK - Pink
QB03LHCL - Clear



Wire ends are covered on all sides to protect against cut hands, damaged product, and punctured gloves.

Regular Basket Shelf — {10.04}

3.5" (89mm) deep basket with 400 lb. (182kg) weight capacity. Ideal for containing and displaying smaller items.

| (in.) | Size (mm) | Cat. No. Chrome | Cat. No. Black |
|-------|-----------|-----------------|----------------|
| 14x36 | 355x914 | — | DD3448A |
| 14x48 | 355x1219 | — | DD3448B |
| 18x36 | 457x914 | CC9744A | CC9744C |
| 18x48 | 457x1219 | CC9744 | CC9744B |



Basket Shelf
(Posts sold separately, see page 42)



LEARN MORE

Quick to find, quick to retrieve,
quick to restock the supplies you need.

qwikSIGHT

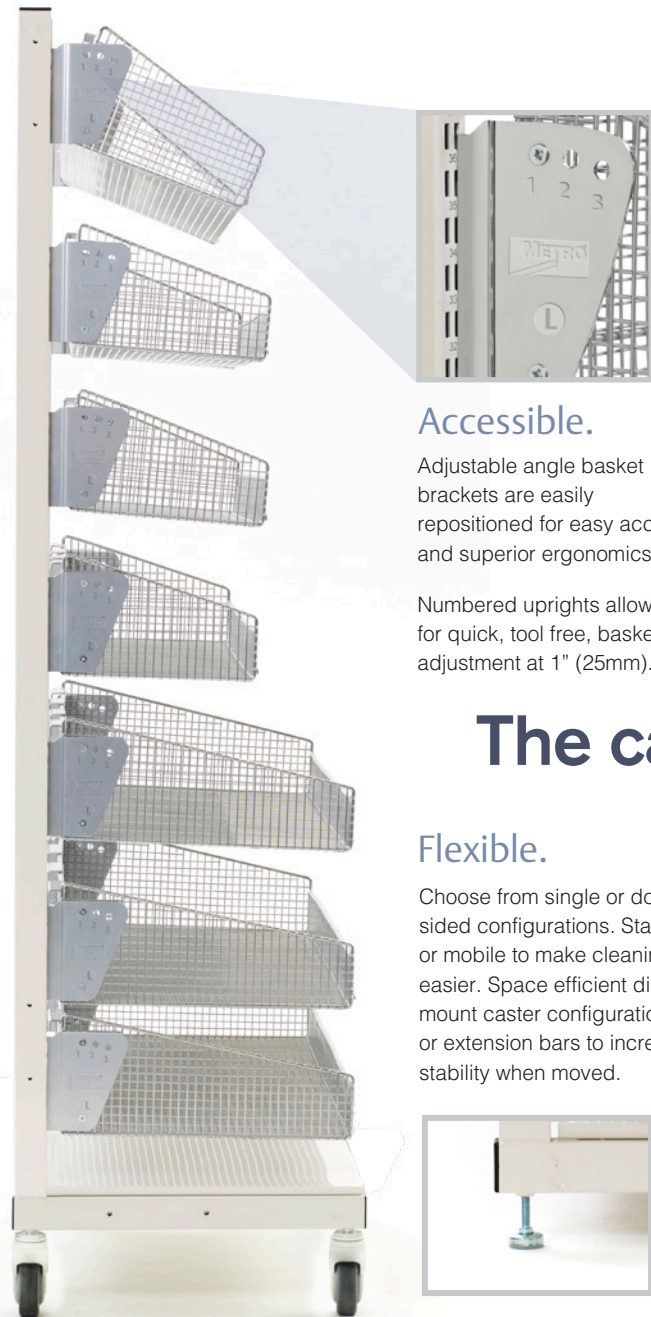

Accessible.

Adjustable angle basket brackets are easily repositioned for easy access and superior ergonomics.

Numbered uprights allow for quick, tool free, basket adjustment at 1" (25mm).



Touchable.



Superior design and high quality production shields personnel and supplies from incidental rips and tears.

The capacity to hold more.

Flexible.

Choose from single or double sided configurations. Stationary or mobile to make cleaning easier. Space efficient direct mount caster configuration or extension bars to increase stability when moved.



Casters are recommended for added clearance to clean under units.



Right sized.

Available in 12" (305mm) or 18" (457mm) widths and 18" (457mm), 36" (914mm) or 48" (1219mm) lengths. Baskets accept optional dividers and label holders.

Hold up to 500 lbs.

100 lbs. (45kg) per basket, 375 lbs. (170kg) per mobile unit, 500 lbs. (227kg) per stationary unit

qwikSIGHT Basket Supply System — {18.01}

Preconfigured Units

Single-Sided Units — 21.5" (546mm) Wide

| Description | Length (mm) | | Height (mm) | | Starter Cat. No. | Add-on Cat. No. |
|---|-------------|------|-------------|------|------------------|-----------------|
| Stationary* 6 Level — Three 12" (305mm) D, Three 18" (457mm) D Baskets | | | | | | |
| 18"L, 6 Basket 3-18, Stationary | 19.5 | 495 | 74 | 1880 | QB118-S6 | QB118-S6A |
| 36"L, 6 Basket 3-18, Stationary | 37.5 | 953 | 74 | 1880 | QB136-S6 | QB136-S6A |
| 48"L, 6 Basket 3-18, Stationary | 49.5 | 1257 | 74 | 1880 | QB148-S6 | QB148-S6A |
| Stationary* 7 Level — Three 12" (305mm) D, Four 18" (457mm) D Baskets | | | | | | |
| 18"L, 7 Basket 4-18, Stationary | 19.5 | 495 | 74 | 1880 | QB118-S7 | QB118-S7A |
| 36"L, 7 Basket 4-18, Stationary | 37.5 | 953 | 74 | 1880 | QB136-S7 | QB136-S7A |
| Mobile** 6 Level — Three 12" (305mm) D, Three 18" (457mm) D Baskets | | | | | | |
| 18"L, 6 Basket 3-18, Mobile | 19.5 | 495 | 79.5 | 2019 | QB118-M6 | QB118-M6A |
| 36"L, 6 Basket 3-18, Mobile | 37.5 | 953 | 79.5 | 2019 | QB136-M6 | QB136-M6A |
| 48"L, 6 Basket 3-18, Mobile | 49.5 | 1257 | 79.5 | 2019 | QB148-M6 | QB148-M6A |
| Mobile** 7 Level — Three 12" (305mm) D, Four 18" (457mm) D Baskets | | | | | | |
| 18"L, 7 Basket 4-18, Mobile | 19.5 | 495 | 79.5 | 2019 | QB118-M7 | QB118-M7A |
| 36"L, 7 Basket 4-18, Mobile | 37.5 | 953 | 79.5 | 2019 | QB136-M7 | QB136-M7A |

*Levelers add .37"-1.12" (16-35mm) to overall height for stationary.

**Mobile units are intended to be moved for cleaning or relocating. Not designed for transport.

†Caster with optional extender adds .5" (13mm) to overall unit height and 4.62" (117mm) to overall width of unit.

‡Add-on — Deduct 1" (25mm) from length shown for Add-on units.

Weight Capacities: Basket — 100 lbs. (45kg), Mobile Unit — 375 lbs. (170kg), Stationary Unit — 500 lbs. (227kg)



QB136-M6



QB148-S7

Double-Sided Units — 40.5" (1029mm) Wide

| Description | Length (mm) | | Height (mm) | | Starter Cat. No. | Add-on Cat. No. |
|---|-------------|------|-------------|------|------------------|-----------------|
| Stationary* 6 Level — Six 12" (305mm) D, Six 18" (457mm) D Baskets | | | | | | |
| 18"L, 12 Basket 6-18, Stationary | 19.5 | 495 | 74 | 1880 | QB218-S12 | QB218-S12A |
| 36"L, 12 Basket 6-18, Stationary | 37.5 | 953 | 74 | 1880 | QB236-S12 | QB236-S12A |
| 48"L, 12 Basket 6-18, Stationary | 49.5 | 1257 | 74 | 1880 | QB248-S12 | QB248-S12A |
| Stationary* 7 Level — Six 12" (305mm) D, Eight 18" (457mm) D Baskets | | | | | | |
| 18"L, 14 Basket 8-18, Stationary | 19.5 | 495 | 74 | 1880 | QB218-S14 | QB218-S14A |
| 36"L, 14 Basket 8-18, Stationary | 37.5 | 953 | 74 | 1880 | QB236-S14 | QB236-S14A |
| 48"L, 14 Basket 8-18, Stationary | 49.5 | 1257 | 74 | 1880 | QB248-S14 | QB248-S14A |
| Mobile** 6 Level — Six 12" (305mm) D, Six 18" (457mm) D Baskets | | | | | | |
| 18"L, 12 Basket 6-18, Mobile | 19.5 | 495 | 79.5 | 2019 | QB218-M12 | QB218-M12A |
| 36"L, 12 Basket 6-18, Mobile | 37.5 | 953 | 79.5 | 2019 | QB236-M12 | QB236-M12A |
| 48"L, 12 Basket 6-18, Mobile | 49.5 | 1257 | 79.5 | 2019 | QB248-M12 | QB248-M12A |
| Mobile** 7 Level — Six 12" (305mm) D, Eight 18" (457mm) D Baskets | | | | | | |
| 18"L, 14 Basket 8-18, Mobile | 19.5 | 495 | 79.5 | 2019 | QB218-M14 | QB218-M14A |
| 36"L, 14 Basket 8-18, Mobile | 37.5 | 953 | 79.5 | 2019 | QB236-M14 | QB236-M14A |
| 48"L, 14 Basket 8-18, Stationary | 49.5 | 1257 | 79.5 | 2019 | QB248-M14 | QB248-M14A |

*Levelers add .37"-1.12" (16-35mm) to overall height for stationary.

**Mobile units are intended to be moved for cleaning or relocating. Not designed for transport.

†Caster with optional extender adds .5" (13mm) to overall unit height and 4.62" (117mm) to overall width of unit.

‡Add-on — Deduct 1" (25mm) from length shown for Add-on units.

Weight Capacities: Basket — 100 lbs. (45kg), Mobile Unit — 375 lbs. (170kg), Stationary Unit — 500 lbs. (227kg)



QB236-M12



Single-Sided Frame (shown with Casters)



Double-Sided Frame (shown with Casters)

qwikSIGHT® Basket Supply System — {18.01}

Build-a-Unit — Components

| Description | Width x Length (in. (mm)) | | Height (in. (mm)) | | Pkd. Weight (lbs.) (kg) | | Cat. No. |
|--|---------------------------|------|-------------------|------|-------------------------|----|------------------|
| Single Sided — Frames with Dust Cover* 21.5" (546mm)W | | | | | | | |
| 18"L Starter | 19.5 | 495 | 74 | 1880 | 36 | 16 | QB1874-1 |
| 36"L Starter | 37.5 | 953 | 74 | 1880 | 46 | 21 | QB3674-1 |
| 48"L Starter | 49.5 | 1257 | 74 | 1880 | 56 | 25 | QB4874-1 |
| 18"L Adder | 18.5 | 470 | 74 | 1880 | 25 | 11 | QB1874-1A |
| 36"L Adder | 36.5 | 927 | 74 | 1880 | 35 | 16 | QB3674-1A |
| 48"L Adder | 48.5 | 1232 | 74 | 1880 | 45 | 20 | QB4874-1A |

Double Sided — Frames with Dust Cover* 40.5" (1029mm)W

| | | | | | | | |
|--------------|------|------|----|------|----|----|------------------|
| 18"L Starter | 19.5 | 495 | 74 | 1880 | 43 | 20 | QB1874-2 |
| 36"L Starter | 37.5 | 953 | 74 | 1880 | 55 | 25 | QB3674-2 |
| 48"L Starter | 49.5 | 1257 | 74 | 1880 | 67 | 30 | QB4874-2 |
| 18"L Adder | 18.5 | 470 | 74 | 1880 | 30 | 14 | QB1874-2A |
| 36"L Adder | 36.5 | 927 | 74 | 1880 | 42 | 19 | QB3674-2A |
| 48"L Adder | 48.5 | 1232 | 74 | 1880 | 54 | 24 | QB4874-2A |

Casters and Caster Extension Bars**

| | | | | | | | |
|-----------------------------------|--------------|-----------|----|----|----|---|---------------|
| 4" Diameter Brake Caster (Qty. 1) | 1.25 x 4 | 32 x 102 | | | 7 | 3 | QB4B |
| Single-Sided Caster Extension Bar | 26.12 x 1.12 | 664 x 29 | .5 | 13 | 10 | 5 | QB18EB |
| Double-Sided Caster Extension Bar | 44.25 x 1.12 | 1124 x 29 | .5 | 13 | 13 | 6 | QB36EB |

Baskets with Brackets

| | | | | | | | |
|----------------------------------|---------|------------|---|-----|----|---|----------------|
| 12"D x 18"L Basket with Brackets | 12 x 18 | 305 x 457 | 7 | 178 | 7 | 3 | QB1218B |
| 12"D x 36"L Basket with Brackets | 12 x 36 | 305 x 914 | 7 | 178 | 10 | 5 | QB1236B |
| 12"D x 48"L Basket with Brackets | 12 x 48 | 305 x 1219 | 7 | 178 | 13 | 6 | QB1248B |
| 18"D x 18"L Basket with Brackets | 18 x 18 | 457 x 457 | 7 | 178 | 8 | 4 | QB1818B |
| 18"D x 36"L Basket with Brackets | 18 x 36 | 457 x 914 | 7 | 178 | 13 | 6 | QB1836B |
| 18"D x 48"L Basket with Brackets | 18 x 48 | 457 x 1219 | 7 | 178 | 16 | 7 | QB1848B |

Shelves with Brackets

| | | | | | | | |
|--------------------------|---------|-----------|----|-----|---|---|-----------------|
| 18" x 18", Slanted Shelf | 18 x 18 | 457 x 457 | 10 | 252 | 4 | 2 | QB1818SS |
| 18" x 36", Slanted Shelf | 18 x 36 | 457 x 914 | 10 | 252 | 7 | 3 | QB1836SS |

Brackets — to convert panel mount baskets to frame mount baskets

| | | | | | | | |
|---|--|--|--|--|-----|-----|----------------|
| Basket/Shelf Brackets, paid (L/R) with Hardware | | | | | 1.7 | 0.8 | QB2BRKT |
|---|--|--|--|--|-----|-----|----------------|

*Levelers add .62"-1.12" (16-35mm) to overall height for stationary.
 **Mobile units are intended to be removed for cleaning or relocating. Not designed for transport.
 **Caster with extender adds .5" (13mm) to overall unit height and 4.62" (117mm) to overall width of unit.

qwikSIGHT® Basket Supply System — {18.01}

Accessories

| Description | Width x Length (in. (mm)) | | Height (in. (mm)) | | Pkd. Weight (lbs.) (kg) | | Cat. No. |
|-----------------------------|---------------------------|-----|-------------------|-----|-------------------------|----|--------------|
| Dividers | | | | | | | |
| 3"H Divider | 6 | 152 | 3 | 76 | .2 | .1 | QB03D |
| 6"H Divider | 6 | 152 | 6 | 152 | .4 | .2 | QB06D |
| 12"L Divider, Front to Back | 12 | 305 | 6 | 152 | .5 | .2 | QB12D |
| 18"L Divider, Front to Back | 18 | 457 | 6 | 152 | .8 | .4 | QB18D |

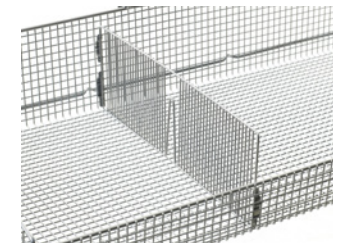

12" or 18" Basket Divider

Label Holders

| | | | | | | | |
|-----------------------------------|----|------|------|----|----|-----|-----------------|
| 18"L Label Holder, Clear (Qty. 1) | 17 | 432 | 1.25 | 32 | .2 | .1 | QB18LHC |
| 36"L Label Holder, Clear (Qty. 1) | 35 | 889 | 1.25 | 32 | .3 | .1 | QB36LHC |
| 48"L Label Holder, Clear (Qty. 1) | 47 | 1194 | 1.25 | 32 | .4 | .2 | QB48LHC |
| 3" Label Holder, Blue (50/pkg.) | 3 | 76 | 1.25 | 32 | .6 | 0.3 | QB03LHBL |
| 3" Label Holder, Clear (50/pkg.) | 3 | 76 | 1.25 | 32 | .6 | 0.3 | QB03LHCL |
| 3" Label Holder, Green (50/pkg.) | 3 | 76 | 1.25 | 32 | .6 | 0.3 | QB03LHGR |
| 3" Label Holder, Orange (50/pkg.) | 3 | 76 | 1.25 | 32 | .6 | 0.3 | QB03LHOR |
| 3" Label Holder, Pink (50/pkg.) | 3 | 76 | 1.25 | 32 | .6 | 0.3 | QB03LHPK |
| 3" Label Holder, Red (50/pkg.) | 3 | 76 | 1.25 | 32 | .6 | 0.3 | QB03LHRD |
| 3" Label Holder, Yellow (50/pkg.) | 3 | 76 | 1.25 | 32 | .6 | 0.3 | QB03LHYL |



QB03D QB06D
Basket Dividers

Louvered Panel and Accessories

| | | | | | | | |
|-----------------------------------|---------|------------|----|------|-----|-----|--------------------|
| 18" x 19" Louvered Panel | 18 | 457 | 19 | 483 | 3 | 1 | QB1819WP |
| 18" x 61" Louvered Panel | 18 | 457 | 61 | 1549 | 9 | 4 | QB1861WP |
| 36" x 19" Louvered Panel | 36 | 914 | 19 | 483 | 5 | 2 | QB3619WP |
| 36" x 61" Louvered Panel | 36 | 914 | 61 | 1549 | 17 | 8 | QB3661WP |
| 18" Frame Mounting Panel Bracket | 5 | 127 | 18 | 457 | 3 | 1 | QB18WPBRKT* |
| 36" Frame Mounting Panel Bracket | 5 | 127 | 36 | 914 | 5 | 2 | QB36WPBRKT* |
| 9" Light-Duty Spike — Single Rod | 9 | 229 | | | 0.1 | 0.1 | QB09WPS |
| 10" Light-Duty Spike — Single Rod | 10 | 254 | | | 0.1 | 0.1 | QB10WPS |
| 12" Equipment Spike — Heavy Duty | 12 | 305 | | | 1 | 1 | QB12WPS |
| 12" x 18" Basket | 12 x 18 | 305 x 457 | 7 | 178 | 6 | 3 | QB1218 |
| 12" x 36" Basket | 12 x 36 | 305 x 914 | 7 | 178 | 10 | 4 | QB1236 |
| 12" x 48" Basket | 12 x 48 | 305 x 1219 | 7 | 178 | 12 | 5 | QB1248 |
| 18" x 18" Basket | 18 x 18 | 457 x 457 | 7 | 178 | 7 | 3 | QB1818 |
| 18" x 36" Basket | 18 x 36 | 457 x 914 | 7 | 178 | 12 | 5 | QB1836 |
| 18" x 48" Basket | 18 x 48 | 457 x 1219 | 7 | 178 | 15 | 7 | QB1848 |

*Brackets are required to mount louvered panel to qwikSIGHT frame. Two for 19"H panel, four for 61"H panel.

Clear Label Holder (shown with labels)



QB36LHC

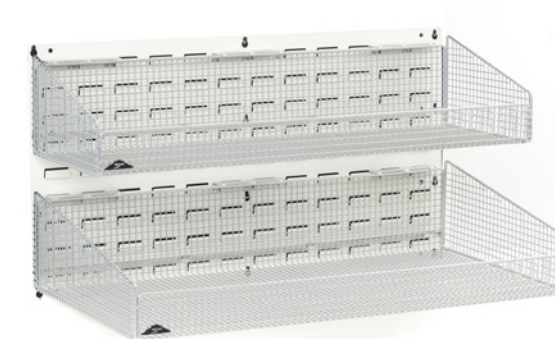

Louvered Panel (Shown with Baskets)

Colored Label Holder (shown with labels)



QB03LHRD - Red QB03LHOR - Orange QB03LHYL - Yellow
 QB03LHGR - Green QB03LHBL - Blue QB03LHPK - Pink
 QB03LHCL - Clear

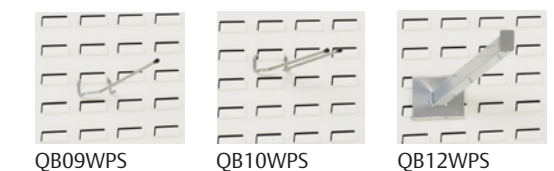

QB09WPS QB10WPS QB12WPS



Metro Bins — {10.08}

Convenient way to organize and identify small items.

Bins of all sizes, for all items.



Must Order Bins & Dividers in Case Quantities.
Part numbers are for individual bins.

Shelf Bins — Nesting

These bins are sized to work on the two most popular shelf widths 18" (457mm) and 24" (610mm) for efficient handling and exchange.



| Part No. | Outside Dimension (in.) | | Outside Dimension (mm) | | Bin Carton Quantity | Bin Color | Width Dividers** | Divider Carton Quantity |
|------------|-------------------------|-------------------------|-------------------------|-------------------------|---------------------|-----------|------------------|-------------------------|
| | Length / Width / Height | Length / Width / Height | Length / Width / Height | Length / Width / Height | | | | |
| MB30110CLN | 11.6 x 2.75 x 4 | 295 x 70 x 102 | 24 | Clear | N/A | N/A | | |
| MB30120CLN | 11.6 x 4.12 x 4 | 295 x 105 x 102 | 24 | Clear | MB40120 (3) | 24 | | |
| MB30130CLN | 11.6 x 6.6 x 4 | 295 x 168 x 102 | 12 | Clear | MB40130 (3) | 24 | | |
| MB30150CLN | 11.6 x 8.37 x 4 | 295 x 213 x 102 | 12 | Clear | - | - | | |
| MB30170CLN | 11.6 x 11.12 x 4 | 295 x 282 x 102 | 12 | Clear | MB40170 (3) | 24 | | |
| MB30128CLN | 17.8 x 4.12 x 4 | 454 x 105 x 102 | 12 | Clear | MB40120 (3) | 24 | | |
| MB30138CLN | 17.8 x 6.6 x 4 | 454 x 168 x 102 | 12 | Clear | MB40130 (3) | 24 | | |
| MB30124CLN | 23.6 x 4.12 x 4 | 600 x 105 x 102 | 12 | Clear | MB40120 (3) | 24 | | |
| MB30164CLN | 23.6 x 6.6 x 4 | 600 x 168 x 102 | 6 | Clear | MB40130 (3) | 24 | | |
| MB30174CLN | 23.6 x 10.6 x 4 | 600 x 270 x 102 | 2 | Clear | MB40170 (3) | 24 | | |

Supply Bins — Stacking or Hanging

Stackable design maximizes vertical storage efficiency. Reinforced design adds strength and prevents spreading. Lip on rear of bin allows bin to hang on the wall panel.



| Part No. | Outside Dimension (in.) | | Outside Dimension (mm) | | Bin Carton Quantity | Color | Length Dividers** | Divider Carton Quantity |
|-------------|-------------------------|-------------------------|-------------------------|-------------------------|---------------------|-------|-------------------|-------------------------|
| | Length / Width / Height | Length / Width / Height | Length / Width / Height | Length / Width / Height | | | | |
| MB30220CLSH | 7.3 x 4.12 x 3 | 187 x 105 x 76 | 24 | Clear | - | - | | |
| MB30237CLSH | 9.25 x 6 x 5 | 235 x 152 x 127 | 12 | Clear | N/A | N/A | | |
| MB30224CLSH | 10.8 x 4.12 x 4 | 276 x 105 x 102 | 12 | Clear | - | - | | |
| MB30230CLSH | 10.8 x 5.5 x 5 | 276 x 140 x 127 | 12 | Clear | MB40230 (1) | 6 | | |
| MB30235CLSH | 10.8 x 11 x 5 | 276 x 279 x 127 | 6 | Clear | MB40230 (2) | 6 | | |
| MB30239CLSH | 10.8 x 8.25 x 7 | 276 x 210 x 178 | 6 | Clear | - | - | | |
| MB30255CLSH | 10.8 x 16.5 x 5 | 276 x 419 x 127 | 6 | Clear | MB40230 (2) | 6 | | |
| MB30234CLSH | 14.75 x 5.5 x 5 | 375 x 140 x 127 | 12 | Clear | - | - | | |
| MB30240CLSH | 14.75 x 8.25 x 7 | 375 x 210 x 178 | 12 | Clear | MB40245 (1) | 6 | | |
| MB30250CLSH | 14.75 x 16.5 x 7 | 375 x 419 x 178 | 12 | Clear | MB40245 (1) | 6 | | |
| MB30265CLSH | 18 x 8.25 x 9 | 457 x 210 x 229 | 6 | Clear | MB40265 (1) | 6 | | |

Note: Bins feature a full-width hanger lip that is designed for use with hanging systems. Bins are available in carton quantities only.

Large Supply Bins — Stacking

Stacking maximizes vertical storage efficiency. Reinforced design prevents spreading.



| Part No. | Outside Dimension (in.) | | Outside Dimension (mm) | | Bin Carton Quantity | Color | Dividers | Divider Carton Quantity |
|------------|-------------------------|-------------------------|-------------------------|-------------------------|---------------------|-------|----------|-------------------------|
| | Length / Width / Height | Length / Width / Height | Length / Width / Height | Length / Width / Height | | | | |
| MB30281CLS | 20 x 12.37 x 8 | 508 x 314 x 203 | 3 | Clear | - | - | | |
| MB30283CLS | 20 x 18.37 x 12 | 508 x 467 x 305 | 1 | Clear | - | - | | |
| MB30284CLS | 23.8 x 8.25 x 7 | 606 x 210 x 178 | 4 | Clear | - | - | | |
| MB30286CLS | 23.8 x 11 x 7 | 606 x 279 x 178 | 4 | Clear | - | - | | |
| MB30289CLS | 23.8 x 18.25 x 12 | 606 x 464 x 305 | 1 | Clear | - | - | | |
| MB30348T | 20.5 x 8.25 x 7 | 521 x 210 x 178 | 6 | Beige | width divider incl. | 1 | | |

**() Recommended max # of dividers per bin = # of divider slots may be higher to provide placement flexibility
Note: Bins are available in carton quantities only. Bins above are priced per each but must be ordered in multiples of carton quantity. (For example: MB30138CLN is available in quantities of 12, 24, 36. List price refers to the price of 1 bin.) Dividers are available in carton quantities only. Dividers are sold by the carton and priced by the carton. (For example: 1 MB40120 = 24 dividers, the list price is for 24 dividers). N/A indicates no divider available. "-" indicates divider available by special request.



Optimize for lean process.

Metro Two-Bin



TWO - DEEP

| Shelf Depth | Part No. | Type |
|-------------|-------------|----------------|
| 18" | MB30220CLSH | Stack/Hang Bin |
| 18" | MB30237CLSH | Stack/Hang Bin |
| 24" | MB30224CLSH | Stack/Hang Bin |
| 24" | MB30230CLSH | Stack/Hang Bin |
| 24" | MB30239CLSH | Stack/Hang Bin |
| 24" | MB30235CLSH | Stack/Hang Bin |
| 24" | MB30255CLSH | Stack/Hang Bin |
| 24" | MB30110CLN | Nesting Bins |
| 24" | MB30120CLN | Nesting Bins |
| 24" | MB30130CLN | Nesting Bins |
| 24" | MB30150CLN | Nesting Bins |
| 24" | MB30170CLN | Nesting Bins |

Part No. is per bin. Must order in case quantity.

TWO - WIDE

| Shelf Depth | Part No. | Type |
|-------------|-------------|----------------|
| 18" | MB30128CLN | Nesting Bins |
| 18" | MB30138CLN | Nesting Bins |
| 18" | MB30265CLSH | Stack/Hang Bin |
| 24" | MB30124CLN | Nesting Bins |
| 24" | MB30164CLN | Nesting Bins |
| 24" | MB30174CLN | Nesting Bins |

Part No. is per bin. Must order in case quantity.

TWO - HIGH

| Shelf Depth | Part No. | Type |
|-------------|------------|--------------|
| 24" | MB30284CLS | Stacking Bin |
| 24" | MB30286CLS | Stacking Bin |
| 24" | MB30289CLS | Stacking Bin |

Part No. is per bin. Must order in case quantity.

Louvered Wall Panel

For use with hanging supply bins. This universal hanging surface provides easy placement and configuration of multiple sizes of bins or qwikSIGHT Baskets. Wall-mounted panels keep items out of the way, off the floor and off the work table.

| Part No. | Outside Dimension (in.) Length / Width / Height | Outside Dimension (mm) Length / Width / Height | Carton Quantity | Color | Weight Capacity (lb.) | Weight Capacity (kg) |
|-----------|--|---|-----------------|-------|-----------------------|----------------------|
| MB1819LWP | 18 x 0.31 x 19 | 457 x 8 x 483 | 4 | White | 160 | 73 |
| MB3619LWP | 36 x 0.31 x 19 | 914 x 8 x 483 | 4 | White | 160 | 73 |
| MB1861LWP | 18 x 0.31 x 61 | 457 x 8 x 1549 | 1 | White | 500 | 227 |

Note: Panel should be mounted on standard stud centers or a solid substrate (block, plywood, etc.) with fasteners in each mounting hole for maximum rigidity. Weight capacity listed is for the panel properly mounted to studs or a solid substrate. Fasteners are not included.

1" (25mm) Bin Rail Dividers

Create slots for bins and other packages as part of lean Kanban systems. Mounting clips attach to wire shelves and MetroMax open grid shelves. Kit consists of (8) chrome plated divider rails and (16) polymer mounting clips.

| Part No. | Fits Shelf Depth (in.) | Fits Shelf Depth (mm) | Approx. Pkd. Wt. (lbs.) | Approx. Pkd. Wt. (kg) |
|----------|------------------------|-----------------------|-------------------------|-----------------------|
| BINRL18 | 18, 21 | 457, 533 | 6.3 | 2.9 |
| BINRL24 | 24 | 610 | 7.8 | 3.5 |

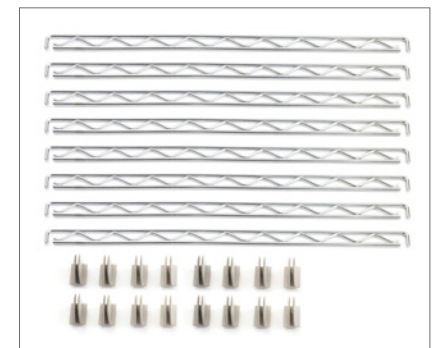



Take
advantage
of every
square inch.



qwikTRAK™
Top-Track™

SECURITY, TRACK & SEISMIC SHELVING

- Security, Track & Seismic Shelving.....94-117
- Security Shelving.....96-99
- High-Density Track Shelving 100-110
- Vertical Extra-High Shelving..... 111
- Seismic Shelving 112-117



Units DO NOT include intermediate shelves.
Intermediate shelves must be ordered separately.



Units DO NOT include intermediate shelves.
Intermediate shelves must be ordered separately.

Intermediate Shelves for Super Erecta Security Units

| Shelf Size W x L | Cat No. Chrome | Cat No. Stainless Steel |
|------------------|----------------|-------------------------|
| 18x36 | A1836NC | A1836NS |
| 18x48 | A1848NC | A1848NS |
| 24x36 | A2436NC | A2436NS |
| 24x48 | A2448NC | A2448NS |
| 24x60 | A2460NC | A2460NS |
| 30x36 | A3036NC | A3036NS |
| 30x48 | A3048NC | A3048NS |
| 30x60 | A3060NC | A3060NS |

| Shelf Size W x L | Cat No. Metroseal Green | Cat No. Super Erecta Pro |
|------------------|-------------------------|--------------------------|
| 18"x36 | A1836NK3 | PR1836NK3 |
| 18"x48 | A1848NK3 | PR1848NK3 |
| 24"x36 | A2436NK3 | PR2436NK3 |
| 24"x48 | A2448NK3 | PR2448NK3 |
| 24"x60 | A2460NK3 | PR2460NK3 |
| 30"x36 | A3036NK3 | PR3036NK3 |
| 30"x48 | A3048NK3 | PR3048NK3 |
| 30"x60 | A3060NK3 | PR3060NK3 |

Note: Standard Super Erecta shelves can also be used as intermediate shelves. Refer to page 48 for more information.

Standard-Duty Stem Caster Models — Stainless Steel — {14.01} 62" (1575mm) high

Casters must be ordered separately. See pages 58-59, or consult your Metro representative for the proper caster for your application. Intermediate shelves are not included with base models and must be ordered separately.

| Description | Width (in.) (mm) | Length (in.) (mm) | Fits Shelf (in.) (mm) | Cat. No. Stainless Steel |
|---------------|------------------|-------------------|-----------------------|--------------------------|
| Standard Duty | 21.5 546 | 40.75 1035 | 18x36 457x914 | SEC33S-SD |
| Standard Duty | 21.5 546 | 52.75 1340 | 18x48 457x1219 | SEC35S-SD |
| Standard Duty | 27.25 692 | 40.75 1035 | 24x36 610x914 | SEC53S-SD |
| Standard Duty | 27.25 692 | 52.75 1340 | 24x48 610x1219 | SEC55S-SD |
| Standard Duty | 27.25 692 | 65 1651 | 24x60 610x1524 | SEC56S-SD |
| Standard Duty | 33.5 851 | 40.75 1035 | 30x36 760x914 | SEC63S-SD |
| Standard Duty | 33.5 851 | 52.75 1340 | 30x48 760x1219 | SEC65S-SD |
| Standard Duty | 33.5 851 | 65 1651 | 30x60 760x1524 | SEC66S-SD |

Note: Given height is for unit without casters. For approximate overall unit height add chosen caster diameter plus 1" (25mm). Large casters can create a tipping hazard. On security units using 18" (457mm) deep shelving, do not use casters larger than 5" (127mm) in diameter.

Heavy-Duty Models — Stainless Steel — {14.01} 62" (1575mm) high

Heavy-duty stainless steel models include staked posts for use with standard Metro dollies. Dolly bases and plate casters must be ordered separately. See pages 60-61, or consult your Metro representative for the proper caster for your application. Intermediate shelves are not included with base models and must be ordered separately.

| Description | Width (in.) (mm) | Length (in.) (mm) | Fits Shelf (in.) (mm) | Cat. No. Stainless Steel |
|-------------|------------------|-------------------|-----------------------|--------------------------|
| Heavy Duty | 28.06 713 | 38.5 980 | 24x36 610x914 | SEC53S-HD |
| Heavy Duty | 28.06 713 | 50.5 1285 | 24x48 610x1219 | SEC55S-HD |
| Heavy Duty | 28.06 713 | 63.13 1600 | 24x60 610x1524 | SEC56S-HD |

Note: Given height is for unit without a Metro dolly or casters. **Note:** To calculate the actual height of the unit using plate casters: 62" [1575mm] + .25" [6mm] for dolly + load height of the caster (found on page 61). Dolly bases are recommended for applications where security units will be transported over the road. Please consult your Metro representative for the appropriate casters and accessories for these applications.

Super Erecta Security Modules — {14.01}

Convert a standard 24" (610mm) wide unit into a security module with this convenient kit.

- Used to enclose one or more areas of a unit.
- Fits between shelves spaced 20" (510mm) apart on any Super Erecta Shelving unit.
- Adapts to 24" (610mm) wide shelves in 30," 48" and 60" (760, 1219 and 1524mm) lengths.

| Width/Length (in.) (mm) | Height (in.) (mm) | Cat. No. Chrome | Cat. No. Stainless Steel |
|-------------------------|-------------------|-----------------|--------------------------|
| 24x30 610x760 | 20 510 | SECM2430NC | SECM2430NS |
| 24x48 610x1219 | 20 510 | SECM2448NC | * |
| 24x60 610x1524 | 20 510 | SECM2460NC | * |

Note: Security Module consists of side panels, back panels and door. Posts and shelves sold separately, see page 48. When multiple security modules are stacked on one shelving unit, separate top and bottom shelves are still necessary for each module. Security modules must be used with Super Erecta Shelf wire shelves. *Consult your Metro representative for availability.

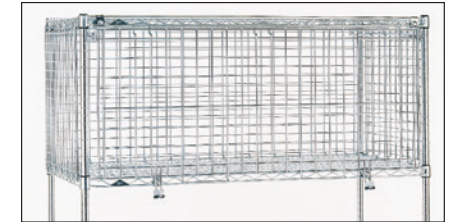

SECM2430NC Assembled on Shelving Unit

Most popular Chrome Security Units with (2) intermediate shelves included.

Easy Order with one Part #

| (in.) Depth x Height | (mm) Depth x Width x Height | Description | Cat. No. |
|----------------------|-----------------------------|-------------|-----------|
| 24 x 36 x 74 | 609 x 914 x 1879 | Mobile | SEC53C-4 |
| 24 x 48 x 74 | 609 x 1219 x 1879 | Mobile | SEC55C-4 |
| 24 x 60 x 74 | 609 x 1524 x 1879 | Mobile | SEC56C-4 |
| 24 x 36 x 74 | 609 x 914 x 1879 | Stationary | SEC53EC-4 |
| 24 x 48 x 74 | 609 x 1219 x 1879 | Stationary | SEC55EC-4 |
| 24 x 60 x 74 | 609 x 1524 x 1879 | Stationary | SEC56EC-4 |



SEC55C shown with optional Super Adjustable intermediate shelves.

Super Erecta® Shelf Stationary Security — {14.01} 66.81" (1695mm) high

- Double Door: Doors open 270 degrees and can be secured along sides.
- Shipped Knocked-Down: Saves on freight costs. Easily assembled.

| Width (in.) (mm) | Length (in.) (mm) | Fits Shelf (in.) (mm) | Cat. No. Chrome | Cat. No. Metroseal Green with Microban® | Cat. No. Stainless Steel |
|------------------|-------------------|-----------------------|-----------------|---|--------------------------|
| 21.5 546 | 38.5 980 | 18x36 457x914 | SEC33C | SEC33K3 | SEC33S |
| 21.5 546 | 50.5 1295 | 18x48 457x1219 | SEC35C | SEC35K3 | SEC35S |
| 27.25 692 | 38.5 980 | 24x36 610x914 | SEC53C | SEC53K3 | SEC53S |
| 27.25 692 | 50.5 1295 | 24x48 610x1219 | SEC55C | SEC55K3 | SEC55S |
| 27.25 692 | 62.5 1587 | 24x60 610x1524 | SEC56C | SEC56K3 | SEC56S |
| 33.5 851 | 38.5 980 | 30x36 760x914 | SEC63C | | SEC63S |
| 33.5 851 | 50.5 1295 | 30x48 760x1219 | SEC65C | | SEC65S |
| 33.5 851 | 62.5 1587 | 30x60 760x1524 | SEC66C | | SEC66S |



SEC55DC shown with optional Super Adjustable intermediate shelves (sold separately). Doors open 270° and can be secured to the sides of the cart.

Super Erecta® Mobile Security — {14.01}

Standard-Duty Stem Caster Models — Chrome & Metroseal Green Include 5" (127mm) casters.

| Caster Type | Width (in.) (mm) | Length (in.) (mm) | Fits Shelf (in.) (mm) | Cat. No. Chrome | Cat. No. Metroseal Green with Microban® |
|------------------|------------------|-------------------|-----------------------|-----------------|---|
| (2) 5MP/(2) 5MPB | 21.5 546 | 40.75 1035 | 18x36 457x914 | SEC33EC | SEC33EK3 |
| (2) 5MP/(2) 5MPB | 21.5 546 | 52.75 1340 | 18x48 457x1219 | SEC35EC | SEC35EK3 |
| (4) 5MP | 27.25 692 | 40.75 1035 | 24x36 610x914 | SEC53DC | SEC53DK3 |
| (4) 5MP | 27.25 692 | 52.75 1340 | 24x48 610x1219 | SEC55DC | SEC55DK3 |
| (4) 5MP | 27.25 692 | 65 1651 | 24x60 610x1524 | SEC56DC | SEC56DK3 |
| (2) 5MP/5MPB | 27.25 692 | 40.75 1035 | 24x36 610x914 | SEC53EC | SEC53EK3 |
| (2) 5MP/5MPB | 27.25 692 | 52.75 1340 | 24x48 610x1219 | SEC55EC | SEC55EK3 |
| (2) 5MP/5MPB | 27.25 692 | 65 1651 | 24x60 610x1524 | SEC56EC | SEC56EK3 |
| (2) 5PC/5PCB | 27.25 692 | 40.75 1035 | 24x36 610x914 | SEC53VK3 | |
| (2) 5PC/5PCB | 27.25 692 | 52.75 1340 | 24x48 610x1219 | SEC55VK3 | |
| (2) 5PC/5PCB | 27.25 692 | 65 1651 | 24x60 610x1524 | SEC56VK3 | |
| (2) 5MP/(2) 5MPB | 33.5 851 | 40.75 1035 | 30x36 760x914 | SEC63EC | |
| (2) 5MP/(2) 5MPB | 33.5 851 | 52.75 1340 | 30x48 760x1219 | SEC65EC | |
| (2) 5MP/(2) 5MPB | 33.5 851 | 65 1651 | 30x60 760x1524 | SEC66EC | |

Casters: 5MP and 5MPB (with locking brake) feature a polyurethane tread. 5PC and 5PCB (with locking brake) casters feature a polymer horn and resist rusting. They are recommended for high moisture environments. Large casters can create a tipping hazard. On security units using 18" (457mm) deep shelving, do not use casters larger than 5" (127mm) in diameter. **Overall height:** Models with 5MP casters – 67.94" (1726mm) high Models with 5PC casters – 68.44" (1739mm) high

Heavy-Duty Models — Chrome & Metroseal Green — {14.01} 68.44" (1739mm) high

Chrome and Metroseal Green models feature aluminum dollies with wraparound bumpers and 5" (127mm) diameter casters.

| Caster Type | Width (in.) (mm) | Length (in.) (mm) | Fits Shelf (in.) (mm) | Cat. No. Chrome | Cat. No. Metroseal Green with Microban® |
|--------------|------------------|-------------------|-----------------------|-----------------|---|
| (2) B5P/B5PB | 28.06 713 | 38.5 980 | 24x36 610x914 | SEC53LC | SEC53LK3 |
| (2) B5P/B5PB | 28.06 713 | 50.5 1285 | 24x48 610x1219 | SEC55LC | SEC55LK3 |
| (2) B5P/B5PB | 28.06 713 | 63.13 1600 | 24x60 610x1524 | SEC56LC | SEC56LK3 |



SEC55LC shown with optional Super Adjustable intermediate shelves.



Clips snap easily into slots along post length to support shelves.

Units DO NOT include intermediate shelves.
Intermediate shelves must be ordered separately.

qwikSLOT® Security Units — {14.01}

Add/Remove-A-Shelf Feature: Allows the unit to quickly adapt to your changing storage needs.

Security with easier to adjust shelves.

Shown with optional intermediate shelves (not included)

qwikSLOT Stationary Security

| Width | | Actual Length | | Height | | Fits Shelf | | Approx. Pkd. Wt. | | Cat. No. Chrome |
|-------|------|---------------|------|--------|------|------------|----------|------------------|------|-----------------|
| (in.) | (mm) | (in.) | (mm) | (in.) | (mm) | (in.) | (mm) | (lbs.) | (kg) | |
| 21.5 | 546 | 38.5 | 980 | 66.81 | 1695 | 18x36 | 457x914 | 138 | 63 | SEC33CQ |
| 21.5 | 546 | 50.5 | 1283 | 66.81 | 1695 | 18x48 | 457x1219 | 157 | 71 | SEC35CQ |
| 27.25 | 705 | 38.5 | 980 | 66.81 | 1695 | 24x36 | 610x914 | 154 | 70 | SEC53CQ |
| 27.25 | 705 | 50.5 | 1283 | 66.81 | 1695 | 24x48 | 610x1219 | 174 | 79 | SEC55CQ |
| 27.25 | 705 | 62.5 | 1587 | 66.81 | 1695 | 24x60 | 610x1524 | 195 | 89 | SEC56CQ |

Intermediate Shelves for qwikSLOT Security Units

| Width | | Length | | Cat. No. Chrome |
|-------|------|--------|------|-----------------|
| (in.) | (mm) | (in.) | (mm) | |
| 18 | 457 | 36 | 914 | 1836QBR |
| 18 | 457 | 48 | 1219 | 1848QBR* |
| 24 | 610 | 36 | 914 | 2436QBR* |
| 24 | 610 | 48 | 1219 | 2448QBR* |
| 24 | 610 | 60 | 1524 | 2460QBR |

*Chrome qwikSLOT shelves sizes: 18x36, 18x48, 24x36, and 24x48 (457x914, 457x1219, 610x914, 610x1219, and 610x1524).
**Drop Mat qwikSLOT shelves with 1" (25mm) ledge available sizes: 24x36, 24x48 (610x914, 610x1219).

qwikSLOT Mobile Security

Standard-Duty Stem Caster Models: feature 5" (127mm) swivel casters. Please note model numbers for specific caster types.

| Caster Type | Width | | Actual Length | | Height | | Fits Shelf | | Approx. Pkd. Wt. | | Cat. No. Chrome |
|--------------|-------|------|---------------|------|--------|------|------------|----------|------------------|------|-----------------|
| | (in.) | (mm) | (in.) | (mm) | (in.) | (mm) | (in.) | (mm) | (lbs.) | (kg) | |
| (2) 5MP/5MPB | 21.5 | 546 | 40.75 | 1035 | 67.94 | 1726 | 18x36 | 457x914 | 146 | 66 | SEC33ECQ |
| (2) 5MP/5MPB | 21.5 | 546 | 52.75 | 1340 | 67.94 | 1726 | 18x48 | 457x1219 | 165 | 75 | SEC35ECQ |
| (4) 5MP | 27.25 | 692 | 40.75 | 1035 | 67.94 | 1726 | 24x36 | 610x914 | 162 | 74 | SEC53DCQ |
| (4) 5MP | 27.25 | 692 | 52.75 | 1340 | 67.94 | 1726 | 24x48 | 610x1219 | 182 | 83 | SEC55DCQ |
| (4) 5MP | 27.25 | 692 | 65 | 1651 | 67.94 | 1726 | 24x60 | 610x1524 | 203 | 92 | SEC56DCQ |
| (2) 5MP/5MPB | 27.25 | 692 | 40.75 | 1035 | 67.94 | 1726 | 24x36 | 610x914 | 162 | 74 | SEC53ECQ |
| (2) 5MP/5MPB | 27.25 | 692 | 52.75 | 1340 | 67.94 | 1726 | 24x48 | 610x1219 | 182 | 83 | SEC55ECQ |
| (2) 5MP/5MPB | 27.25 | 692 | 65 | 1651 | 67.94 | 1726 | 24x60 | 610x1524 | 203 | 92 | SEC56ECQ |

Casters: 5MP and 5MPB (with locking brake) feature a polyurethane tread. 5PC and 5PCB (with locking brake) casters feature a polymer horn and resist rusting. They are recommended for high moisture environments.
NOTE: Large casters can create a tipping hazard. On 18" (457mm) security units, do not use casters larger than 5" (127mm) in diameter.

Heavy-Duty qwikSlot Mobile Security

Feature aluminum dollies with wraparound bumpers and 5" (127mm) diameter casters.

| Caster Type | Width | | Actual Length | | Height | | Fits Shelf | | Cat. No. Chrome |
|--------------|-------|------|---------------|------|--------|------|------------|----------|-----------------|
| | (in.) | (mm) | (in.) | (mm) | (in.) | (mm) | (in.) | (mm) | |
| (2) 5BP/5BPB | 28.06 | 713 | 38.5 | 980 | 68.44 | 1739 | 24x36 | 610x914 | SEC53LCQ |
| (2) 5BP/5BPB | 28.06 | 713 | 50.5 | 1283 | 68.44 | 1739 | 24x48 | 610x1219 | SEC55LCQ |
| (2) 5BP/5BPB | 28.06 | 713 | 63.13 | 1600 | 68.44 | 1739 | 24x60 | 610x1524 | SEC56LCQ |



qwikSLOT Locking Clip

Recommended for mobile applications. Must be used with 9985QS shelf clips. (Package of 4)
Cat. No. **9985QSL**



Corrosion resistance, removable shelf mats & antimicrobial protection at all touch-points.

MetroMax Q Security Units — {14.01}

- Heavy gauge open wire construction.
- Microban antimicrobial product protection is built into the enclosures, doors, handles, and shelves.
- Optional intermediate shelves: MetroMax Q quick adjust shelves or corrosion proof MetroMax i.
- Ergonomic 1/4-turn door handle: Doors open 270 degrees and can be secured along sides.

MetroMax Q Stationary Units — 66.19" (1681mm) High

| Actual Outside Dimensions | | | | Fits Shelf | | Cat. No. |
|---------------------------|------|--------|------|------------|----------|-----------------|
| Width | | Length | | (in.) | (mm) | |
| (in.) | (mm) | (in.) | (mm) | (in.) | (mm) | |
| 26.94 | 685 | 38.88 | 987 | 24x36 | 610x914 | MQSEC53E |
| 26.94 | 685 | 50.88 | 1292 | 24x48 | 610x1219 | MQSEC55E |
| 26.94 | 685 | 62.88 | 1597 | 24x60 | 610x1524 | MQSEC56E |

Note: Leveling foot on post can be adjusted up to 1" (25mm) to compensate for uneven floors.

MetroMax Q Stem Caster Mobile Units — 67.81" (1723mm) High

Models include four 5" (127mm) diameter casters with polyurethane tread; two swivel and two swivel with brakes.

| Actual Outside Dimensions (including Bumpers and Handle) | | | | Fits Shelf | | Cat. No. Includes Casters with Plated Finish | Cat. No. Includes Corrosion Resistant Polymer Casters |
|--|------|--------|------|------------|----------|--|---|
| Width | | Length | | (in.) | (mm) | | |
| (in.) | (mm) | (in.) | (mm) | (in.) | (mm) | | |
| 27.81 | 707 | 40.75 | 1035 | 24x36 | 610x914 | MQSEC53DE | MQSEC53VE |
| 27.81 | 707 | 52.75 | 1340 | 24x48 | 610x1219 | MQSEC55DE | MQSEC55VE |
| 27.81 | 707 | 64.75 | 1645 | 24x60 | 610x1524 | MQSEC56DE | MQSEC56VE |

**"DE" models use two 5MPX and two 5MPBX casters.

***"VE" models use two 5PCX and two 5PCBX casters. Recommended for wet or damp environments.

MetroMax Q Heavy-Duty Mobile Units — 68.5" (1740mm) High

Mounted on aluminum dolly with 5" (127mm) plate casters and wraparound bumpers.

| Actual Outside Dimensions (including Handle) | | | | Fits Shelf | | Approx. Pkd. Wt. | | Cat. No. |
|--|------|--------|------|------------|----------|------------------|------|------------------|
| Width | | Length | | (in.) | (mm) | (lbs.) | (kg) | |
| (in.) | (mm) | (in.) | (mm) | (in.) | (mm) | (lbs.) | (kg) | |
| 28.06 | 713 | 39.13 | 994 | 24x36 | 610x914 | 166 | 75 | MQSEC53LE |
| 28.06 | 713 | 51.13 | 1299 | 24x48 | 610x1219 | 176 | 80 | MQSEC55LE |
| 28.06 | 713 | 63.13 | 1603 | 24x60 | 610x1524 | 179 | 81 | MQSEC56LE |

Note: The aluminum dollies used on the LE models have two B5P and two B5PB plate casters.



MQSEC53VE with optional intermediate shelves



Ergonomic 1/4-turn door handle



Units DO NOT include intermediate shelves.
Intermediate shelves must be ordered separately.

Standard Units consist of top and bottom wire shelves, tri-lobal adapters, steel posts, wire enclosures, and doors. Casters are included with mobile units.

Intermediate Shelves for MetroMax Q Security

| Width | | Length | | Cat. No. Shelf with Grid Mat | Cat. No. Shelf with Solid Mat | Cat. No. Shelf with Grid Mat |
|-------|------|--------|------|------------------------------|-------------------------------|------------------------------|
| (in.) | (mm) | (in.) | (mm) | | | |
| 24 | 610 | 36 | 914 | MX2436G | MX2436F | MQ2436G |
| 24 | 610 | 48 | 1220 | MX2448G | MX2448F | MQ2448G |
| 24 | 610 | 60 | 1524 | MX2460G | MX2460F | MQ2460G |



GET ON TRACK. THE ULTIMATE STORAGE METHOD.



THE SECRET TO MAXIMIZING STORAGE IS THE **ACTIVE AISLE** CONCEPT.

qwikTRAK Floor Track Systems

- ✓ Perfect for heavy loads.
- ✓ Smooth Gliding – Tracks protect floors from wear.
- ✓ Floor tracks compensate for rough floors.
- ✓ Aluminum & stainless track construction.



Double-Deep Configurations can be created where two systems are joined together to increase the overall depth of the storage system for even greater storage capacity.

qwikTRAK (Both single- and double-deep systems) can be used with Metro wire shelving (Super Erecta or Super Adjustable Super Erecta) and polymer shelving systems (MetroMax i and MetroMax Q). MetroMax 4 can be used on single-deep systems.



The easiest way to build track shelving.

BOOST STORAGE SPACE BY UP TO **50%** WITH NO ADDED CONSTRUCTION COSTS.

Top-Track Overhead Track Systems



- ✓ Floors are easy to clean.
- ✓ Easy Access – Roll carts in & out of the aisles.
- ✓ Ideal for uneven floor surfaces.
- ✓ All-polymer options available.



ADA Compliant

Top-Track (single deep) can be used with Metro wire shelving (Super Erecta or Super Adjustable Super Erecta) and polymer shelving systems (MetroMax i, MetroMax 4 and MetroMax Q).

Double-Deep configurations can be created when two systems are joined together to increase the overall depth of the storage system for even greater storage capacity. Double-Deep Top-Track is only available for Super Erecta and Super Adjustable Super Erecta style shelving.

HIGH-DENSITY STORAGE — QWIKTRAK™



qwikTRAK Storage System — {11.15}

Super Erecta, Super Erecta Pro, Super Adjustable, MetroMax Q, MetroMax i, MetroMax 4



Getting started:

Document the available floor space

- Actual length: Nominal track length + the nominal width of each end unit + 3" (76mm)
- Actual width: Nominal Shelf length + 3.5" (89mm)
- Actual height of a mobile qwikTRAK unit is: Nominal post height + 4.5" (115mm)

It is recommended that the tracks are installed at least 2" (52mm) from the wall.

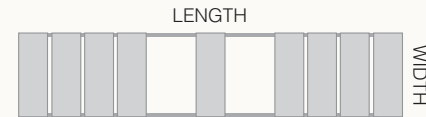

Shelves Sold Separately: All end, intermediate, and mobile units must be 18" (457mm) or wider. Each stationary end and intermediate unit must have a minimum of four shelves. Super Adjustable shelves may be used for all tiers.

Stationary End Unit Kit (Choose one kit for each system)

Includes 74" high posts (1880mm) high stationary posts, and hardware necessary for connecting stationary end units to tracks. Shelves are sold separately.

| Super Erecta, Super Erecta Pro, Super Adjustable Super Erecta | | | | MetroMax Q Steel Posts | MetroMax Polymer Posts |
|---|--------------------------|-------------------------|--------------------------|------------------------|------------------------|
| Cat. No. Chrome Plated | Cat. No. Metroseal Green | Cat. No. Metroseal Gray | Cat. No. Stainless Steel | Cat. No. | Cat. No. |
| BTEC | BTEK3 | BTEK4 | BTES | BTEQ3 | BTEX3 |



Stationary Intermediate Units

Required when overall desired track length exceeds 21' (6405mm). Optional when track length is under 21' (6405mm). Includes 74" high posts (1880mm) high stationary posts, and hardware necessary for connecting one stationary intermediate unit to tracks. Shelves are sold separately.

| Super Erecta, Super Erecta Pro, Super Adjustable Super Erecta | | | | MetroMax Q Steel Posts | MetroMax Polymer Posts |
|---|--------------------------|-------------------------|--------------------------|------------------------|------------------------|
| Cat. No. Chrome Plated | Cat. No. Metroseal Green | Cat. No. Metroseal Gray | Cat. No. Stainless Steel | Cat. No. | Cat. No. |
| BTAC | BTAK3 | BTAK4 | BTAS | BTAQ3 | BTAX3 |



Mobile Units (One kit required per mobile unit)

Includes four 74" (1880mm) high mobile posts, four casters, donut bumpers, and other hardware to assemble a mobile unit. Shelves are sold separately.

| Super Erecta, Super Erecta Pro, Super Adjustable Super Erecta | | | | MetroMax Q Steel Posts | MetroMax Polymer Posts |
|---|--------------------------|-------------------------|--------------------------|------------------------|------------------------|
| Cat. No. Chrome Plated | Cat. No. Metroseal Green | Cat. No. Metroseal Gray | Cat. No. Stainless Steel | Cat. No. | Cat. No. |
| BTAC | BTAK3 | BTAK4 | BTAS | BTAQ3 | BTAX3 |

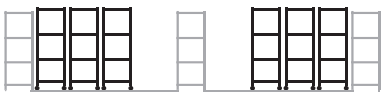

Under normal conditions, aisle width of 30"-36" (760-914mm) is recommended. The storage of very large objects within the system, however, may require an aisle width larger than 36" (914mm).

Note: Casters feature an acetyl grooved wheel. Chrome plated (BTMC) includes casters with plated steel components. BTMK3/BTMS/BTMQ3/BTMX3 include casters with stainless.

Track Sets Includes tracks and hardware needed to assemble track runs up to 21' (6400mm).

| Length (ft.) (mm) | Cat. No. | Length (ft.) (mm) | Cat. No. |
|-------------------|----------|-------------------|----------|
| 2.5 762 | BTS2.5NA | 14 4267 | BTS14NA |
| 6 1828 | BTS6NA | 15 4572 | BTS15NA |
| 7 2135 | BTS7NA | 16 4877 | BTS16NA |
| 8 2440 | BTS8NA | 17 5182 | BTS17NA |
| 9 2743 | BTS9NA | 18 5486 | BTS18NA |
| 10 3048 | BTS10NA | 19 5791 | BTS19NA |
| 11 3352 | BTS11NA | 20 6096 | BTS20NA |
| 12 3657 | BTS12NA | 21 6400 | BTS21NA |
| 13 3962 | BTS13NA | | |

Note: BTS2.5NA includes a joining kit to connect the tracks to other track sets.



The easiest way to build qwikTRAK.

Notes:

1. qwikTRAK is available with 74" posts (1880mm) as standard. Requests for TALLER posts must be reviewed by Metro Engineering. For applications requiring posts SHORTER than 74" (1880mm), contact your Metro representative.
2. Existing Metro Super Erecta, Super Adjustable, MetroMax Q, and MetroMax i shelving units can be retrofitted as part of a qwikTRAK installation.
3. Weight capacities for standard qwikTRAK: Super Erecta, Super Adjustable, MetroMax Q systems are designed to hold up to 2,000 lbs. (907kg) per shelving unit. MetroMax i stationary units can hold up to 2,000 lbs. (907kg); MetroMax i mobile units can hold up to 1,200 lbs. (544kg) per unit. MetroMax 4 stationary units can hold up to 2,000 lbs. (907kg); MetroMax 4 mobile units can hold up to 800 lbs. (363kg) per unit.
4. Added rigidity for heavily loaded systems. Super Erecta standard adjustment shelves provide the most rigid wire shelving mobile units; Recommended when configuring systems using 60" and 72" long shelves subject to the heaviest loads and frequent movement (multiple times daily). MetroMax Q epoxy coated steel posts may be used with MetroMax i shelves for added rigidity when managing sensitive packaged items and heavier unit loads; steel posts are corrosion resistant.



HIGH-DENSITY STORAGE — QWIKTRAK™ DOUBLE DEEP

Double-Deep qwikTRAK Storage System — {11.15a}

Super Erecta, Super Erecta Pro, Super Adjustable, MetroMax Q, MetroMax i, MetroMax 4

Getting started:

Document the available floor space

- Actual length: Nominal track length + the nominal width of each end unit + 3" (76mm)
- Actual width: Nominal Shelf length + 3.5" (89mm)
- Actual height of a mobile qwikTRAK unit is: Nominal post height + 4.5" (115mm)

It is recommended that the tracks are installed at least 2" (52mm) from the wall.

Shelves Sold Separately: All end, intermediate, and mobile units must be 18" (457mm) or wider. Each stationary end and intermediate unit must have a minimum of four shelves. Super Adjustable shelves may be used for all tiers.

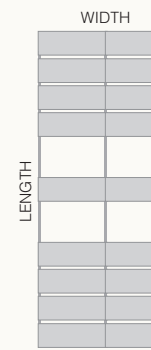

Stationary End Unit Kit (Choose One per double-deep System)

Includes 74" high posts (1880mm) high stationary posts, and hardware necessary for connecting stationary end units to tracks. Shelves are sold separately.

| Super Erecta, Super erecta Pro, Super Adjustable Super Erecta | | | | MetroMax Q Steel Posts | MetroMax Polymer Posts |
|---|--------------------------|-------------------------|--------------------------|------------------------|------------------------|
| Cat. No. Chrome Plated | Cat. No. Metroseal Green | Cat. No. Metroseal Gray | Cat. No. Stainless Steel | Cat. No. | Cat. No. |
| LBTEC | LBTEK3 | LBTEK4 | LBTES | LBTEQ3 | LBTEX3 |

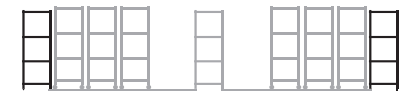

Stationary Intermediate Units

Includes 74" high posts (1880mm) high stationary posts and hardware necessary for connecting one double-deep stationary intermediate unit to tracks and anchoring tracks to the floor. Shelves are sold separately.

| Super Erecta, Super erecta Pro, Super Adjustable Super Erecta | | | | MetroMax Q Steel Posts | MetroMax Polymer Posts |
|---|--------------------------|-------------------------|--------------------------|------------------------|------------------------|
| Cat. No. Chrome Plated | Cat. No. Metroseal Green | Cat. No. Metroseal Gray | Cat. No. Stainless Steel | Cat. No. | Cat. No. |
| LBTAC | LBTAK3 | LBTAK4 | LBTAS | LBTQ3 | LBTAX3 |

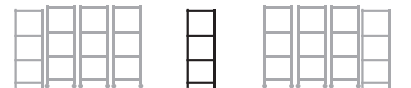

Mobile Units (One kit required per Double-Deep Mobile Unit)

Includes (8) 74" (1880mm) high –UP posts, (4) V-groove casters, (1) stainless steel center channel caster assembly, donut bumpers, Tie Bar Brackets, and other hardware. Shelves are sold separately.

| Super Erecta, Super erecta Pro, Super Adjustable Super Erecta | | | | MetroMax Q Steel Posts | MetroMax Polymer Posts | |
|---|------------------------|--------------------------|-------------------------|--------------------------|------------------------|----------|
| Shelf Width (in) (mm) | Cat. No. Chrome Plated | Cat. No. Metroseal Green | Cat. No. Metroseal Gray | Cat. No. Stainless Steel | Cat. No. | Cat. No. |
| 18 457 | LBTM18C | LBTM18K3 | LBTM18K4 | LBTM18S | LBTM18Q3 | LBTM18X3 |
| 21 530 | LBTM21C | LBTM21K3 | LBTM21K4 | LBTM21S | LBTM21Q3 | — |
| 24 610 | LBTM24C | LBTM24K3 | LBTM24K4 | LBTM24S | LBTM24Q3 | LBTM24X3 |

Note: Casters feature acetyl grooved wheel. Chrome kit includes casters with steel components. Metroseal Green / Stainless Steel / MetroMax Q / MetroMax i kits include casters with stainless components.

Under normal conditions, aisle width of 30"-36" (760-914mm) is recommended. The storage of very large objects within the system, however, may require an aisle width larger than 36" (914mm).



Track Sets Includes tracks and hardware needed to assemble Double-Deep qwikTRAK up to 21' (6400mm).

| Length (ft.) (mm) | Cat. No. | Length (ft.) (mm) | Cat. No. |
|-------------------|-----------|-------------------|----------|
| 2.5 762 | LBTS2.5NA | 14 4267 | LBTS14NA |
| 6 1828 | LBTS6NA | 15 4572 | LBTS15NA |
| 7 2135 | LBTS7NA | 16 4877 | LBTS16NA |
| 8 2440 | LBTS8NA | 17 5182 | LBTS17NA |
| 9 2743 | LBTS9NA | 18 5486 | LBTS18NA |
| 10 3048 | LBTS10NA | 19 5791 | LBTS19NA |
| 11 3352 | LBTS11NA | 20 6096 | LBTS20NA |
| 12 3657 | LBTS12NA | 21 6400 | LBTS21NA |
| 13 3962 | LBTS13NA | | |

Note: LBTS2.5NA includes a joining kit to connect the tracks to other track sets.



The easiest way to build qwikTRAK.

Notes:

1. qwikTRAK is available with 74" posts (1880mm) as standard. Requests for TALLER posts must be reviewed by Metro Engineering. For applications requiring posts SHORTER than 74" (1880mm), contact your Metro representative.
2. Maximum allowable shelf length for use with a double-deep system is 60" (1524mm).
3. The maximum width of a double-deep configuration is 10'6" (3200mm). (i.e., two systems, each having 60" (1524mm) long shelves, plus 6" (150mm) for qwikTRAK components.
4. Weight capacities: Double Deep Mobile Units — Super Erecta/Super Adjustable, Super Erecta/MetroMax Q: 3,000 lbs. (1364kg) evenly distributed. MetroMax i: 1,800 lbs. (818kg) evenly distributed. Stationary End and Intermediate Units — Each end and intermediate double deep unit consists of two independent stationary shelving units positioned side by side. Each shelving unit has a maximum weight capacity of 2,000 lbs. (907kg).



THE ONLY ALL-POLYMER SHELVING

strong enough for overhead track systems.



The easiest way to build Top-Track.



MetroMax.



Top-Track Storage System — {9.29}

Polymer Shelving — MetroMax i, MetroMax 4, MetroMax Q



Getting started:

- Document the available floor space**
- Actual length: Nominal track length + the nominal width of each end unit + 2" (51mm)
 - Actual width: Nominal Shelf length + 3.5" (89mm)
 - Actual height of system is approx. 87" (2210mm)

It is recommended that the tracks are installed at least 5" (127mm) from the wall.

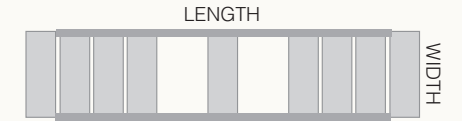

The system compensates for uneven floor surfaces. Floor should be smooth and free from large cracks or raised obstacles. Maximum load capacity for mobile units is 900 lbs. (400kg).

Stationary End Unit Kit (Order one per Top-Track system)

Includes hardware and components to connect track sets to two stationary end units. 86" (2185mm) posts included. Shelves are ordered separately.

| Fits Shelf Width (in.) | (mm) | Polymer Posts | Epoxy Coated Steel Posts |
|------------------------|------|-----------------------|--------------------------|
| | | Cat. No. End Unit Kit | Cat. No. End Unit Kit |
| 18 | 457 | MXTTE18 | MQTTE18 |
| 21 | 530 | MXTTE21 | MQTTE21 |
| 24 | 610 | MXTTE24 | MQTTE24 |



Stationary Intermediate Unit Kit

Required when overall desired track length exceeds 21' (6405mm). Optional when track length is under 21' (6405mm). Includes 86" high posts (2184mm) high stationary posts, and hardware necessary for connecting one stationary intermediate unit to tracks. Shelves are sold separately.

| Fits Shelf Width (in.) | (mm) | Polymer Posts | Epoxy Coated Steel Posts |
|------------------------|------|--------------------------------|--------------------------------|
| | | Cat. No. Intermediate Unit Kit | Cat. No. Intermediate Unit Kit |
| 18 | 457 | MXTTA18 | MQTTA18 |
| 21 | 530 | MXTTA21 | MQTTA21 |
| 24 | 610 | MXTTA24 | MQTTA24 |



Mobile Unit Kit (Order one per mobile unit)

Kit includes 74" (1880mm) posts, rigid casters, caster channels, bumpers, and roller assemblies. Shelves are sold separately.

| Fits Shelf Width (in.) | (mm) | Polymer Posts | Polymer Posts | Epoxy Coated Steel Posts | Epoxy Coated Steel Posts |
|------------------------|------|------------------------------|---------------------------------|------------------------------|---------------------------------|
| | | Cat. No. with Plated Casters | Cat. No. with Stainless Casters | Cat. No. with Plated Casters | Cat. No. with Stainless Casters |
| 18 | 457 | MXTTM18C | MXTTM18S | MQTTM18C | MQTTM18S |
| 21 | 530 | MXTTM21C | MXTTM21S | MQTTM21C | MQTTM21S |
| 24 | 610 | MXTTM24C | MXTTM24S | MQTTM24C | MQTTM24S |

Under normal conditions, aisle width of 30"-36" (760-914mm) is recommended. The storage of very large objects within the system, however, may require an aisle width larger than 36" (914mm).



Track Sets (One track set is required between stationary units)

Includes necessary sections of track for assembling track runs of 6' to 21' (1830-6405mm).

| Length (feet) | (mm) | Approx. Pkd. Wt. (lbs.) | (kg) | Cat. No. | Length (feet) | (mm) | Approx. Pkd. Wt. (lbs.) | (kg) | Cat. No. |
|---------------|------|-------------------------|------|----------------|---------------|------|-------------------------|------|----------------|
| | | | | | | | | | |
| 6 | 1828 | 40.5 | 18.2 | TTS6NA | 15 | 4572 | 106.5 | 47.9 | TTS15NA |
| 7 | 2135 | 47.5 | 21.3 | TTS7NA | 16 | 4877 | 113.5 | 51 | TTS16NA |
| 8 | 2440 | 56 | 25.2 | TTS8NA | 17 | 5182 | 121 | 54.4 | TTS17NA |
| 9 | 2743 | 62.5 | 28.1 | TTS9NA | 18 | 5486 | 128 | 51.6 | TTS18NA |
| 10 | 3048 | 69.5 | 31.2 | TTS10NA | 19 | 5791 | 135 | 60.7 | TTS19NA |
| 11 | 3353 | 76.5 | 34.4 | TTS11NA | 20 | 6096 | 142 | 63.9 | TTS20NA |
| 12 | 3657 | 83.5 | 37.5 | TTS12NA | 21 | 6400 | 149 | 67 | TTS21NA |
| 13 | 3962 | 92 | 41.4 | TTS13NA | | | | | |

Note: TTS2.5NA includes a joining kit to connect the tracks to longer track sections.

- Notes:**
1. Mobile, stationary end, and intermediate units must have a minimum of 4 shelves.
 2. Mobile Units: If 18" (457mm) wide mobile units are planned, the maximum allowable size shelf is 60" (1524mm) long. If 18" (457mm) wide by 60" (1524mm) long mobile units are planned, a maximum of five 18" (457mm) mobile units are allowable between two stationary units. 18" (457mm), 21" (530mm) and 24" (610mm) wide mobile units can be intermixed in a given system. The standard system requires 74" (1880mm) posts on the mobile units. Recommended maximum load rating for a mobile unit is 900 lbs. (410kg).
 3. To accommodate bumpers, the actual size of a mobile unit is 2.5" (63.5mm) wider than the shelf width shown. For example, an 18" (457mm) wide unit is actually 20.5" (521mm).
 4. MetroMax Q epoxy coated steel posts may be used with MetroMax i shelves for added rigidity; steel posts are corrosion resistant.





Top-Track Storage System — {11.12}

Wire Shelving — Super Erecta, Super Erecta Pro, Super Adjustable



Super Erecta® Top-Track®



Getting started:

- Document the available floor space
 - Actual length: Nominal track length + the nominal width of each end unit + 2" (51mm)
 - Actual width: Nominal Shelf length + 3.5" (89mm)
 - Actual height of system is approx. 87" (2210mm)

It is recommended that the tracks are installed at least 5" (127mm) from the wall.

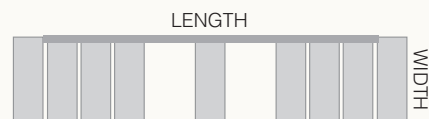

Shelves Sold Separately: All end, intermediate, and mobile units must be 18" (457mm) or wider. Each stationary end and intermediate unit must have a minimum of four shelves. Super Adjustable shelves may be used for all tiers.

Stationary End Unit Kits (One kit is required per single system)
Includes hardware necessary for connecting stationary end units to track. 86" (2185mm) posts are included. Shelves sold separately.

| Shelf Width (in) (mm) | Cat. No. Chrome Plated | Cat. No. Metroseal Green | Cat. No. Metroseal Gray | Cat. No. Stainless Steel |
|-----------------------|------------------------|--------------------------|-------------------------|--------------------------|
| 18 457 | TTE18C | TTE18K3 | TTE18K4 | TTE18S |
| 21 530 | TTE21C | TTE21K3 | TTE21K4 | TTE21S |
| 24 610 | TTE24C | TTE24K3 | TTE24K4 | TTE24S |



Stationary Intermediate Units

Required when overall desired track length exceeds 21' (6405mm). Optional when track length is under 21' (6405mm). Includes 86" high posts (2184mm) high stationary posts, and hardware necessary for connecting one stationary intermediate unit to tracks. Shelves are sold separately.

| Shelf Width (in) (mm) | Cat. No. Chrome Plated | Cat. No. Metroseal Green | Cat. No. Metroseal Gray | Cat. No. Stainless Steel |
|-----------------------|------------------------|--------------------------|-------------------------|--------------------------|
| 18 457 | TTA18C | TTA18K3 | TTA18K4 | TTA18S |
| 21 530 | TTA21C | TTA21K3 | TTA21K4 | TTA21S |
| 24 610 | TTA24C | TTA24K3 | TTA24K4 | TTA24S |

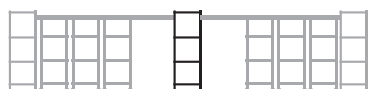

Mobile Unit Kits (One kit required per mobile unit)

Kit includes special 74" (1880mm) posts, casters/caster channels, donut bumpers, and roller bearing assemblies. Shelves are sold separately.

| Shelf Width (in) (mm) | Overall Width (in) (mm) | Cat. No. Chrome Plated | Cat. No. Metroseal Green | Cat. No. Metroseal Gray | Cat. No. Stainless Steel |
|-----------------------|-------------------------|------------------------|--------------------------|-------------------------|--------------------------|
| 18" 457 | 20 1/4 514 | TTM18C | TTM18K3 | TTM18K4 | TTM18S |
| 21 530 | 23 1/4 590 | TTM21C | TTM21K3 | TTM21K4 | TTM21S |
| 24 610 | 26 1/4 667 | TTM24C | TTM24K3 | TTM24K4 | TTM24S |

Note: Casters feature wheels with polyurethane tread. Chrome plated kits include casters with plated steel components. Metroseal and Stainless Steel kits include casters with stainless steel components.

Under normal conditions, aisle width of 30"-36" (760-914mm) is recommended. The storage of very large objects within the system, however, may require an aisle width larger than 36" (914mm).

* If 18" wide mobile units are planned, the maximum allowable length shelf is 60" (1524mm) long. If 18" (457mm) wide by 60" (1524mm) long mobile units are planned, a maximum of five 18" (457mm) mobile units are allowable between two stationary units. 18" (457mm), 21" (530mm), 24" (610mm) wide mobile units can be intermixed in a given system.



Track Sets Includes tracks and hardware needed to assemble runs up to 21' (6400mm).

| Length (ft.) (mm) | Cat. No. | Length (ft.) (mm) | Cat. No. |
|-------------------|----------|-------------------|----------|
| 2.5 762 | TTS2.5NA | 14 4267 | TTS14NA |
| 6 1828 | TTS6NA | 15 4572 | TTS15NA |
| 7 2135 | TTS7NA | 16 4877 | TTS16NA |
| 8 2440 | TTS8NA | 17 5182 | TTS17NA |
| 9 2743 | TTS9NA | 18 5486 | TTS18NA |
| 10 3048 | TTS10NA | 19 5791 | TTS19NA |
| 11 3352 | TTS11NA | 20 6096 | TTS20NA |
| 12 3657 | TTS12NA | 21 6400 | TTS21NA |
| 13 3962 | TTS13NA | | |

Note: TTS2.5NA includes a joining kit to connect the tracks to other track sets.



The easiest way to build Top-Track.

Additional Notes:

- To accommodate bumpers, the actual size of a mobile unit is 2.5" (63.5mm) wider than the shelf width shown. For example, an 18" (457mm) wide unit is actually 20.5" (522mm).
- Recommended maximum load rating for a mobile unit is 900 lbs. (410kg). Floor should be level, smooth, and free from large cracks and raised obstacles.
- Added rigidity for heavily loaded systems. Super Erecta standard adjustment shelves provide the most rigid wire shelving mobile units. Recommended when configuring systems using 60" (1524mm) and 72" (1829mm) long shelves subject to the heaviest loads and frequent movement (multiple times daily).



Easy Order with one Part #.

Get all you need to create efficient high-density storage under one simple part number.

10ft. Fits spaces 10ft. and over

| Complete System Length (ft./in.) (mm) | System Width (in.) (mm) | Chrome Top-Track Easy Order Model | Super Erecta Pro Top-Track Easy Order Model |
|---------------------------------------|-------------------------|-----------------------------------|---|
| 9' 7" 2921 | 48 1219 | TT10-E2148M1848C | TT10-E2148M1848P |
| 9' 7" 2921 | 60 1524 | TT10-E2160M1860C | TT10-E2160M1860P |

Models Contain
(1) 6' Track Set, (8) 86" Posts, (1) 18" Tie Bar End Kit, (8) 74" Top Trk Mobile Posts, (2) 18" Mobile Kits, (16) Shelves
Note: Chrome systems use chrome posts and plated casters. SE Pro uses Metroseal Green Posts and Stainless casters.



21" (530mm) End Width
18" (457mm) Mobile Width
48" (1219mm) or 60" (1524mm) Shelf Length

12ft. Fits spaces 12ft. and over

| Complete System Length (ft./in.) (mm) | System Width (in.) (mm) | Chrome Top-Track Easy Order Model | Super Erecta Pro Top-Track Easy Order Model |
|---------------------------------------|-------------------------|-----------------------------------|---|
| 11' 7" 3531 | 48 1219 | TT12-E2448M1848C | TT12-E2448M1848P |
| 11' 7" 3531 | 60 1524 | TT12-E2460M1860C | TT12-E2460M1860P |

Models Contain
(1) 7.5' Track Set, (8) 86" Posts, (1) 18" Tie Bar End Kit, (12) 74" Top Trk Mobile Posts, (3) 18" Mobile Kits, (20) Shelves
Note: Chrome systems use chrome posts and plated casters. SE Pro uses Metroseal Green Posts and Stainless casters.



24" (610mm) End Width
18" (457mm) Mobile Width
48" (1219mm) or 60" (1524mm) Shelf Length

14ft. Fits spaces 14ft. and over

| Complete System Length (ft./in.) (mm) | System Width (in.) (mm) | Chrome Top-Track Easy Order Model | Super Erecta Pro Top-Track Easy Order Model |
|---------------------------------------|-------------------------|-----------------------------------|---|
| 13' 7" 4140 | 48 1219 | TT14-E2448M1848C | TT14-E2448M1848P |
| 13' 7" 4140 | 60 1524 | TT14-E2460M1860C | TT14-E2460M1860P |

Models Contain
(1) 9.5' Track Set, (8) 86" Posts, (1) 18" Tie Bar End Kit, (16) 74" Top Trk Mobile Posts, (4) 18" Mobile Kits, (24) Shelves
Note: Chrome systems use chrome posts and plated casters. SE Pro uses Metroseal Green Posts and Stainless casters.



24" (610mm) End Width
18" (457mm) Mobile Width
48" (1219mm) or 60" (1524mm) Shelf Length

16ft. Fits spaces 16ft. and over

| Complete System Length (ft./in.) (mm) | System Width (in.) (mm) | Chrome Top-Track Easy Order Model | Super Erecta Pro Top-Track Easy Order Model |
|---------------------------------------|-------------------------|-----------------------------------|---|
| 15' 7" 4750 | 48 1219 | TT16-E2448M2448C | TT16-E2448M2448P |
| 15' 7" 4750 | 60 1524 | TT16-E2460M2460C | TT16-E2460M2460P |

Models Contain
(1) 11.5' Track Set, (8) 86" Posts, (1) 18" Tie Bar End Kit, (16) 74" Top Trk Mobile Posts, (4) 18" Mobile Kits, (24) Shelves
Note: Chrome systems use chrome posts and plated casters. SE Pro uses Metroseal Green Posts and Stainless casters.



24" (610mm) End Width
24" (610mm) Mobile Width
48" (1219mm) or 60" (1524mm) Shelf Length

The numbers don't lie...

30% More Storage.

Conventional 16' of Storage



16' of Top-Track Storage





Double-Deep Top-Track Storage System — {11.12a}

Wire Shelving — Super Erecta, Super Erecta Pro, Super Adjustable

Stationary End Units (One kit required for entire double deep configuration)

Includes hardware necessary for connecting stationary end units in double-deep systems and connecting to an overhead track set. 86" (2185mm) posts included. Shelves sold separately.

| Shelf Width (in.) | (mm) | Approx. Pkd. Wt. (lbs.) | (kg) | Cat. No. Chrome-Plated |
|-------------------|------|-------------------------|------|------------------------|
| 18 | 457 | 33 | 14.8 | LTTE18C |
| 21 | 530 | 37 | 16.6 | LTTE21C |
| 24 | 610 | 41 | 18.4 | LTTE24C |



Stationary Intermediate Units (One kit required for Intermediate units connected end-to-end)

Includes hardware necessary for connecting intermediate units in double-deep systems and connecting to an overhead track set on each side. 86" (2185mm) posts included.

| Shelf Width (in.) | (mm) | Approx. Pkd. Wt. (lbs.) | (kg) | Cat. No. Chrome-Plated |
|-------------------|------|-------------------------|------|------------------------|
| 18 | 457 | 18 | 8 | LTTA18C |
| 21 | 530 | 20 | 9 | LTTA21C |
| 24 | 610 | 22 | 9.9 | LTTA24C |

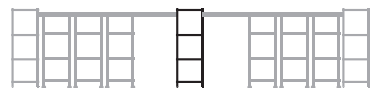

Mobile Unit Kits (One kit required per mobile unit)

Includes posts, casters, caster channels, donut bumpers, roller bearing assemblies, and tie-together hardware to connect two mobile units.

| Shelf Width (in.) | (mm) | Overall Width (in.) | (mm) | Approx. Pkd. Wt. (lbs.) | (kg) | Cat. No. Chrome-Plated |
|-------------------|------|---------------------|------|-------------------------|------|------------------------|
| 18 | 457 | 20 1/4 | 514 | 72 | 32.4 | LTTM18C |
| 21 | 530 | 23 1/4 | 590 | 75 | 33.7 | LTTM21C |
| 24 | 610 | 26 1/4 | 667 | 78 | 35 | LTTM24C |



Track Sets Includes necessary sections of track for assembling track runs up to 21' (6400mm).

For track sizes within the even 1-foot (305mm) increments, contact your Metro representative. Only one track set is required between stationary units.

| Length (feet) | (mm) | Approx. Pkd. Wt. (lbs.) | (kg) | Cat. No. | Length (feet) | (mm) | Approx. Pkd. Wt. (lbs.) | (kg) | Cat. No. |
|---------------|------|-------------------------|------|----------|---------------|------|-------------------------|------|----------|
| 2.5 | 762 | 15 | 6.8 | TTS2.5NA | 14 | 4267 | 98 | 44.1 | TTS14NA |
| 6 | 1828 | 40.5 | 18.2 | TTS6NA | 15 | 4572 | 106.5 | 47.9 | TTS15NA |
| 7 | 2135 | 47.5 | 21.3 | TTS7NA | 16 | 4877 | 113.5 | 51 | TTS16NA |
| 8 | 2440 | 56 | 25.2 | TTS8NA | 17 | 5182 | 121 | 54.4 | TTS17NA |
| 9 | 2743 | 62.5 | 28.1 | TTS9NA | 18 | 5486 | 128 | 51.6 | TTS18NA |
| 10 | 3048 | 69.5 | 31.2 | TTS10NA | 19 | 5791 | 135 | 60.7 | TTS19NA |
| 11 | 3353 | 76.5 | 34.4 | TTS11NA | 20 | 6096 | 142 | 63.9 | TTS20NA |
| 12 | 3657 | 83.5 | 37.5 | TTS12NA | 21 | 6400 | 149 | 67 | TTS21NA |
| 13 | 3962 | 92 | 41.4 | TTS13NA | | | | | |

Note: TTS2.5NA includes a joining kit to connect the tracks to longer track sections.

Notes:

- Each stationary end and intermediate unit must have a minimum of four shelves. For all Super Adjustable applications, the top and bottom shelves must be non "quick adjust" Super Erecta shelves.
- The standard Double Deep Top-Track system requires the use of 86" (2185mm) posts (i.e., 86P) on the stationary end and intermediate units. **Shelves for the stationary end and intermediate units are sold separately.**
- The mobile unit kits include special 74" (1880mm) posts with casters. **Shelves for mobile units are sold separately.**
- Under normal conditions, an aisle width of 30"-36" (760-914mm) is recommended. The storage of very large objects within the system, however, may require an aisle width larger than 36" (914mm).
- Two intermediate shelving units connected end-to-end are required when the track length exceeds 21 feet (6400mm). Stationary intermediate shelving units may be used at the discretion of the user when track lengths are less than 21 feet (6400mm).
- The maximum Double Deep system configuration is 10'6" (3200mm) (i.e., two systems, each having 60" (1524mm) long shelves, plus 6" (150mm) for Top-Track components).
- Ease of rollability for the mobile units is an important consideration in evaluating Top-Track as a possible storage alternative. The floor should be level, smooth, and free from large cracks and raised obstacles. Two mobile shelving units connected end-to-end and loaded with between 800 to 1,200 lbs. (365-550kg) will require a human effort range (in lbs. of human force) of between 18-24 lbs. (8-11kg) to move the unit from a complete stop. Subjectively, an average 110 lb. (50kg) person will perceive this as acceptable effort levels. For loads over 1,200 lbs. (550kg), contact your Metro representative.
- Mobile units should have the top shelf positioned as close as possible to the track.
- To accommodate bumpers, the actual size of a mobile unit is 2.5" (63.5mm) wider than the shelf width shown. For example, an 18" (457mm) wide unit is actually 20.5" (522mm).
- To calculate the overall length of a Super Erecta Top Track System, add the following:
Nominal track length + Nominal widths of each end unit + 1.5" (38mm).

Getting started:

Document the available floor space

- Actual length: Nominal track length + the nominal width of each end unit + 2" (51mm)
- Actual width: Nominal Shelf length + 3.5" (89mm)
- Actual height of system is approx. 87" (2210mm)

It is recommended that the tracks are installed at least 5" (127mm) from the wall.

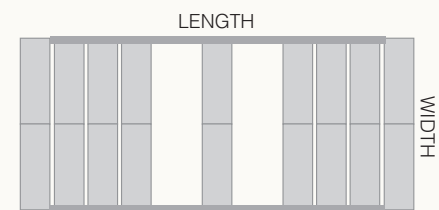

The easiest way to build Top-Track.

Note: for other finishes please contact your Metro representative.

For Top-Track accessories, see page 110.



Seismic Top-Track® Single Length System

End Unit Kit:

Includes four shelves, four staked posts, bracket bars, sway braces (for top, back, and end), anchor plates, foot plates, tubular braces, clamps, and assembly hardware.

| Description | Cat. No. |
|--|----------|
| Kit for 48" (1219mm) Stationary End Unit | SA48TTS |
| Kit for 54" (1370mm) Stationary End Unit | SA54TTS |
| Kit for 60" (1524mm) Stationary End Unit | SA60TTS |

Strut Kit:

| Description | Cat. No. |
|--------------------------------|------------|
| Kit for 48" (1219mm) Wide Unit | TTB48STRUT |
| Kit for 54" (1370mm) Wide Unit | TTB54STRUT |
| Kit for 60" (1524mm) Wide Unit | TTB60STRUT |

Note: Floor anchoring hardware not included.

Example: For a complete "Single-Length Top-Track System," the following would be required: Two Stationary End Units, One Track Set (11-foot [3355mm] maximum), One Center Strut (if track length exceeds 7 feet), Mobile Units.

Note: Posts and shelves are included in the end and intermediate unit kits. Shelves are sold separately for the mobile unit.

Add track sets and mobile unit kits, refer to page 106.

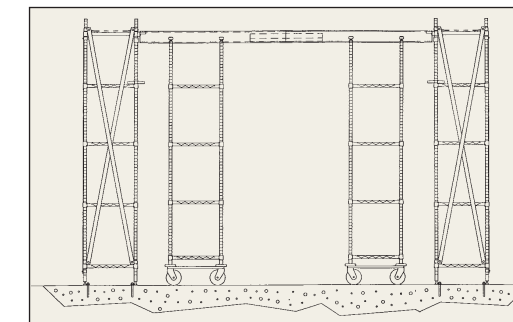

Single-Length System

Seismic Top-Track® Double Length System

End Unit Kits:

Includes four shelves, four staked posts, bracket bars, sway braces (for top, back, and end), anchor plates, foot plates, tubular braces, clamps, and assembly hardware.

| Description | Cat. No. |
|--|----------|
| Kit for 48" (1219mm) Stationary End Unit | SA48TTS |
| Kit for 54" (1370mm) Stationary End Unit | SA54TTS |
| Kit for 60" (1524mm) Stationary End Unit | SA60TTS |

Intermediate Unit Kits:

Includes eight shelves, eight staked posts, bracket bars, sway braces (for top, back, and end), anchor plates, foot plates, tubular braces, clamps, and assembly hardware.

| Description | Cat. No. |
|---|----------|
| Kit for 48" (1219mm) Stationary Intermediate Unit | SA48TTIS |
| Kit for 54" (1370mm) Stationary Intermediate Unit | SA54TTIS |
| Kit for 60" (1524mm) Stationary Intermediate Unit | SA60TTIS |

Strut Kit:

| Description | Cat. No. |
|--------------------------------|------------|
| Kit for 48" (1219mm) Wide Unit | TTB48STRUT |
| Kit for 54" (1370mm) Wide Unit | TTB54STRUT |
| Kit for 60" (1524mm) Wide Unit | TTB60STRUT |

Note: Floor anchoring hardware not included.

Example: For a complete "Double-Length Top-Track System," the following would be required: Two Stationary End Units, Two Track Sets* (11-foot [3355mm] maximum), One Intermediate Unit, Two Center Struts (if track length exceeds 7 feet [2135mm]), Mobile Units.*

Note: Posts and shelves are included in the end and intermediate unit kits. Shelves are sold separately for the mobile unit.

Notes:

- Each installation must have two stationary end units for a single-track length of 7' (2135mm) to 11' (3355mm).
- A center strut is required for each track section over 7' (2135mm).
- For track lengths over 11' (3355mm), an intermediate unit is required, thus creating a double-length system.
- Seismic Top-Track is based upon a weight-loading capacity of 25 lbs. (11kg) per square foot on a four-shelf stationary and mobile units, with maximum of 900 lbs. (408kg) per mobile unit. Additional shelves may be added, but are limited to a maximum load of 25 lbs. (11kg) per cubic foot per unit.
- A maximum of four 21' (6400mm) or 24" (610mm), or five 18" (457mm) mobile units are allowed per an 11' (3355mm) track length, with no more than a 900 lb. (408kg) weight capacity per mobile unit.
- Stationary End Units are available in 24"x48" (610x1219mm), 24"x54" (610x1370mm), and 24"x60" (610x1524mm).
- Seismic Top-Track design is based on the use of HR concrete, at least 5.5" (140mm) thick, with a compressive strength of 3,000 psi (211kg/cm). Anchorage is not included.
- To calculate the overall length of a Super Erecta Top Track System, add the following: Nominal track length + Nominal widths of each end unit + 1.5" (38mm).

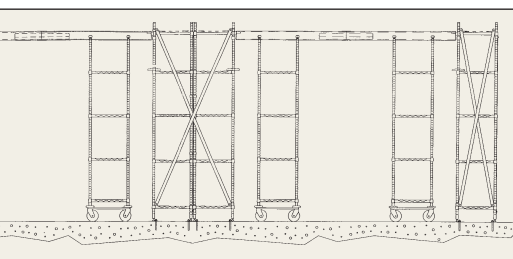

Double-Length System

Add track sets and mobile unit kits, refer to page 106.

See page 112 for Stationary Seismic shelving.

Notes:

- Floor anchors are not included. The structural engineer of record must verify that the anchorage bolt and building structure are adequate for the applied load.
- For Seismic Top-Track, the highest load shelf must be no more than 60" (1524mm) from the floor.
- For Seismic Top-Track, a unit must have no more than four loaded shelves within 60" (1524mm) height.
- If a fifth shelf is used, it must serve only as a cover and not be used for load bearing.
- Each shelving unit, whether single or "back-to-back," cannot connect to other shelving units or walls.

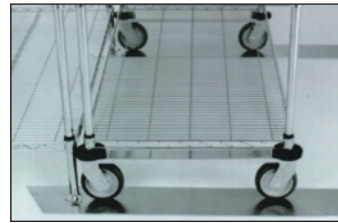

Top-Track® Floor Protectors

Top-Track™ Floor Pad Protectors — {9.29} {11.12}

Use for both MetroMax Top-Track and Super Erecta Top-Track Systems.

| For Track Length (ft.) | For Track Length (mm) | Cat. No. | For Track Length (ft.) | For Track Length (mm) | Cat. No. |
|------------------------|-----------------------|----------|------------------------|-----------------------|----------|
| 6 | 1828 | FPS6N | 14 | 4267 | FPS14N |
| 7 | 2135 | FPS7N | 15 | 4572 | FPS15N |
| 8 | 2440 | FPS8N | 16 | 4877 | FPS16N |
| 9 | 2743 | FPS9N | 17 | 5182 | FPS17N |
| 10 | 3048 | FPS10N | 18 | 5486 | FPS18N |
| 11 | 3353 | FPS11N | 19 | 5791 | FPS19N |
| 12 | 3657 | FPS12N | 20 | 6096 | FPS20N |
| 13 | 3962 | FPS13N | 21 | 6400 | FPS21N |

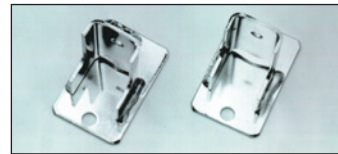

Top-Track® Wall Mount Bracket

Top-Track™ Wall Mount Bracket — {11.12}

Used to attach one set of tracks to the wall. Eliminates the need for a stationary end unit. Includes one pair of wall brackets and hardware to attach tracks to the wall brackets. Hardware to attach the wall brackets to the wall is NOT included.

Cat. No. TTWM



Top-Track® Stop Plate Kit

Top-Track™ Stop Plate Kit — {11.12}

Used in conjunction with the Wall Mount Bracket Kit. The stop plates bolt to the underside of the track next to the wall brackets to prevent the mobile units from bumping into the wall.

Cat. No. TTSTP

Metro Tip:

Floor pad protectors compensate for soft flooring materials by protecting the floor from wear and tear. For new construction projects, it is recommended that flooring of suitable durability is used in areas where Top-Track will be installed.



qwikTRAK Stop Plate Kit

qwikTRAK Stop Plate Kit — {11.15}

Eliminates the need for a stationary end unit. The kit contains two "L-shaped" stop plates that mount to the ends of the floor tracks. The stop plates prevent a mobile unit from rolling off the end of the tracks.

Cat. No. BTSP

Consult your Metro representative for guidance on configuring a qwikTRAK system using this kit.

Stop plates (kit of two) shown mounted to the end plates on the floor tracks.

EFFICIENCY IS ON THE RISE

Short on floor space? Try going vertical.



Super Erecta Hi-Rise Shelving

Super Erecta® Hi-Rise Shelving — {10.17}

- For light-duty storage applications where floor space is at a premium.
- Construct shelving up to 24 feet (7315mm) high — 3 times the height of conventional shelving
- Metro's computerized engineering system assures correct specifications and load rating of Hi-Rise materials for your application.

All Hi-Rise installations must be reviewed and approved by Metro Engineering. Hi-Rise certification plate supplied. Only Super Erecta and Super Adjustable Super Erecta wire shelves can be used in Hi-Rise applications. Contact Metro customer service or your local Metro representative for details.

Metro Tip:

One frequently overlooked opportunity to gain additional storage capacity is the efficient use of vertical space. By connecting Super Erecta posts, storage areas may be created that utilize every available cubic foot of unused vertical air space.

Material part numbers will be provided by Metro Product Development upon review of application.



Strength, it's what we stand for.



Metro® Seismic Shelving HCAI (OSHPD) Preapproval provides certified components for securing Metro shelving in active seismic zones.

Metro's exclusive patented design is intended for a facility to save thousands in engineering fees, by achieving preapproval on seismic project plans. Metro's design takes those savings a step further.

The Metro Seismic Shelving options have earned an HCAI (The Department of Health Care Access and Information) or OSHPD (Office of Statewide Health Planning and Development) preapproval driven by the state of California specific to projects subject to the 2019 California Building Code (CBC).



SEISMIC WIRE ASSEMBLY



Metro Super Erecta® Stand-alone unit



MetroMax® i Stand-alone unit



SEISMIC POLYMER ASSEMBLY



HCAI Preapproval Base Plate Kits — {10.15}

| Description | Approx Pkg. Wt. (lbs.) | (kg) | Cat. No. |
|---------------------------------------|------------------------|------|---------------------|
| 1-post, 2-3 bolt triangular plate kit | 9.8 | 4.4 | SABP13BR-4PK |
| 1-post, 4-bolt square plate kit | 12.5 | 5.7 | SABP14BR-4PK |
| 2-post, 5- bolt rectangular plate kit | 10.8 | 4.9 | SABP25BR-2PK |
| 4-post, 6 bolt plate square bolt kit | 8.4 | 3.8 | SABP46BR-1PK |

Note: These base plate kits must be used with the HCAI (OSHPD) Preapproval posts and cannot be retrofitted to standard posts or staked posts.

SABP13BR-4PK
1-post, 2-3 bolt triangular plate kit includes:

- (4) chromate-plated base plates, each with a single post socket
- (1) bag of four clevis pins and four cotter pins
- (4) hole covers
- (2) seismic labels
- (2) SES label holders.

SABP14BR-4PK
1-post, 4-bolt, square plate kit includes:

- (4) chromate-plated base plates, each with a single post socket
- (1) bag of four clevis pins and four cotter pins
- (2) seismic labels
- (2) SES label holders.

SABP25BR-2PK
2-post, 5 bolt rectangular plate kit includes:

- (2) chromate-plated base plates, each with two post sockets
- (1) bag of four clevis pins and four cotter pins
- (2) seismic labels
- (2) SES label holders.

SABP46BR-1PK
4-post, 6-bolt plate, square bolt kit includes:

- (1) chromate plated base plate with 4 post sockets
- (1) bag of four clevis pins and four cotter pins
- (2) seismic labels
- (2) SES label holders.

HCAI Preapproved Posts & Post Clamps — {10.15}

Required for use with Base Plate Kits.

Super Erecta Post: Chrome plated, 1" (25mm) diameter posts with a welded insert and seismic leveler bolt.

MetroMax Post: Steel post with a welded insert and a seismic leveler bolt. Epoxy-coated finish with Microban antimicrobial product protection over a chromate substrate. Seismic bolt is chromate-plated steel.

Post Clamps: Stainless steel. There are versions for Super Erecta posts and MetroMax posts.

Seismic Leveler Bolt: Chromate-plated steel.

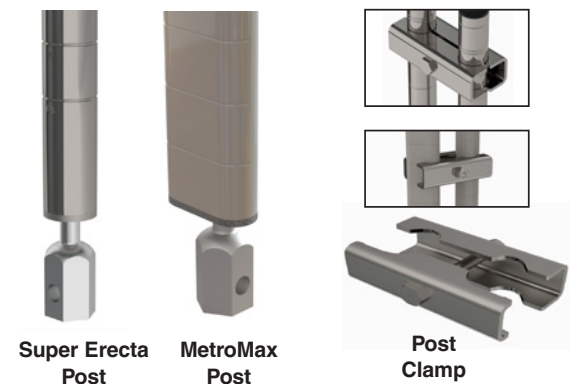

Super Erecta® and Super Adjustable Super Erecta®

| Cat. No. | Description | Nominal Height | | Actual Height | | Actual width | | Approx Pkd. Weight | |
|-----------------|--|----------------|------|---------------|------|--------------|------|--------------------|------|
| | | (in.) | (mm) | (in.) | (mm) | (in.) | (mm) | (lbs.) | (kg) |
| SA63P | Seismic HCAI Preapproval 63" Chrome Plated Post | 63 | 1600 | 63.6250 | 1616 | 1 | 25 | 4.0 | 1.8 |
| SA74P | Seismic HCAI Preapproval 74" Chrome Plated Post | 74 | 1880 | 75.6875 | 1922 | 1 | 25 | 4.8 | 2.2 |
| SA86P | Seismic 86" Chrome Plated Post | 86 | 2185 | 87.6875 | 2227 | 1 | 25 | 5.5 | 2.5 |
| SAPCLAMP | Seismic HCAI Preapproval Stainless Steel Post Clamp for Super Erecta | | | 1.1250 | 29 | | | 0.7 | 0.3 |

NOTE: 86" posts (SA86P) can be used to earn site specific approvals using the OPM# 0426 base plates and post clamps.

MetroMax® i and MetroMax® Q

| Cat. No. | Description | Nominal Height | | Actual Height | | Actual width | | Approx Pkd. Weight | |
|------------------|---|----------------|------|---------------|------|--------------|------|--------------------|------|
| | | (in.) | (mm) | (in.) | (mm) | (in.) | (mm) | (lbs.) | (kg) |
| SAMQ63PE | Seismic HCAI Preapproval MetroMax 63" Post | 63 | 1600 | 62.6250 | 1591 | 1.5 | 38 | 4.4 | 2.0 |
| SAMQ74PE | Seismic HCAI Preapproval MetroMax 74" Post | 74 | 1880 | 74.6250 | 1895 | 1.5 | 38 | 4.9 | 2.2 |
| SAMQ86PE | Seismic HCAI Preapproval MetroMax 86" Post | 86 | 2185 | 86.6250 | 2200 | 1.5 | 38 | 5.7 | 2.6 |
| SAPCLAMPX | Seismic HCAI Pre-approved Stainless Steel Post Clamp for MetroMax | | | 1.1250 | 29 | | | 0.6 | 0.3 |

Reference these spec sheets for shelves: Super Erecta (10.01), Super Adjustable (10.01A), MetroMax i (9.20), MetroMax Q (9.21).



Configurations for Super Erecta® & MetroMax Shelving

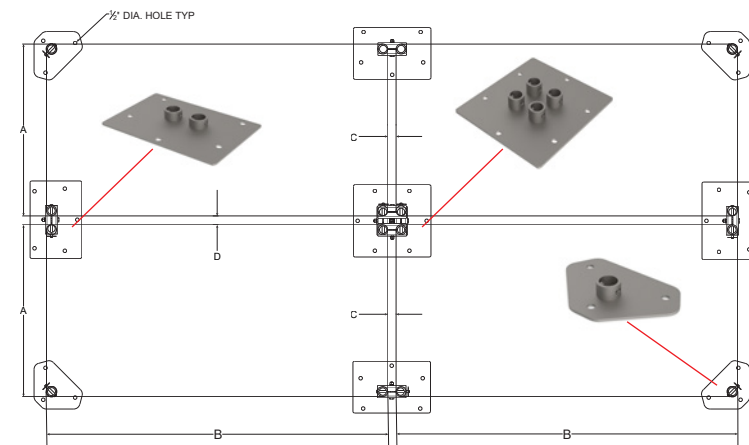
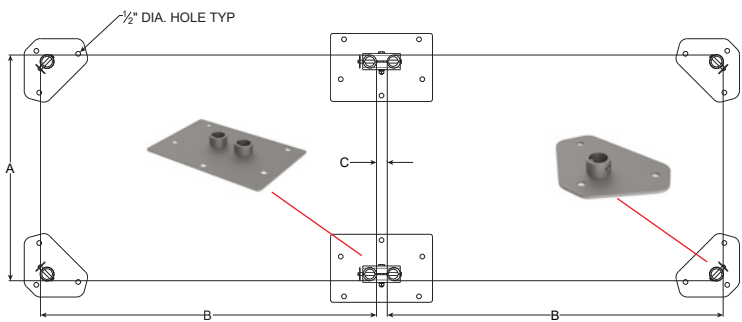
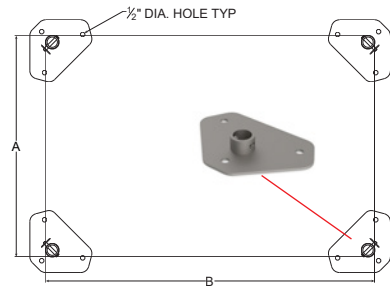

Super Erecta® and Super Adjustable Super Erecta® Installations.

| Dimensions | Super Erecta / Super Adjustable |
|------------|-------------------------------------|
| A | 18", 21", 24" (457, 530, 620mm) |
| B | 23-3/4" thru 71-3/4" (603 - 1822mm) |
| C | 1-5/32" (29mm) |
| D | 1-5/32" (29mm) |

MetroMax® Q Installations.

| Dimensions | MetroMax Q |
|------------|-------------------------------------|
| A | 18", 21", 24" (457, 530, 620mm) |
| B | 23-1/2" thru 71-1/2" (597 - 1816mm) |
| C | 1-7/32" (31mm) |
| D | 1-1/4" (32mm) |

MetroMax® i Installations.

| Dimensions | MetroMax i |
|------------|---------------------------------------|
| A | 18", 24" (457, 620mm) |
| B | 23-9/16" thru 71-9/16" (598 - 1816mm) |
| C | 1-5/32" (29mm) |
| D | 1-1/4" (32mm) |



A secure mounting connection combined with robust Metro shelving.

- Low profile base plates.
- No drilling of posts.
- Flexible hardware placement
- Easy to install.
- Easy to level.



OPM-0426

HCAI (OSHPD) Preapproval **OPM-0426** specifically outlines the configuration requirements for HCAI (OSHPD) governed healthcare facilities in the state of California subject to the 2019 California Building Codes. (Note: These requirements may vary in different jurisdictions.)

The HCAI0 Preapproval outlines the following:

Weight Loads (for installations subject to HCAI Preapproval)

20 PSF/tier for a shelving unit. The maximum load bearing of a shelving unit is defined as a five tier unit with four storage tiers and an open top shelf (no load).

Example 1: 24x48x74, 4-tier unit. Maximum load bearing per shelf is 20 lbs. x 8 sq ft = 160 lbs. The total unit is rated using this formula: 4 tiers x 160 lbs. per tier = 640 lbs.

Example 2: 24x48x74, 6-tier unit. Maximum load bearing per 24x48 unit is 640 lbs. A 6-tier unit is defined to have 5 storage tiers. and an open top shelf. 640 lbs. / 5 tiers = 128 lbs. per tier.

Positioning of bottom shelf: maximum of 10" (254mm) from the floor.

Seismic Zones are called out within OPM-0426.

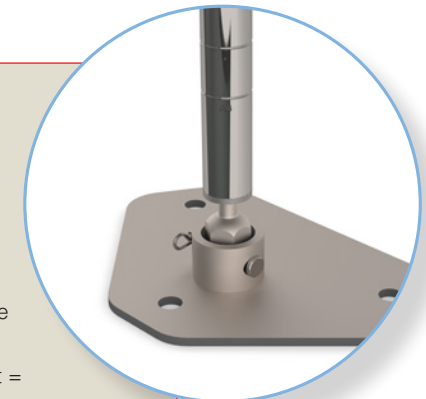

Anchorage Bolts: Metro does not provide the concrete floor anchorage bolts. The engineer of record for a site specific job must verify that the building structure is adequate for the applied load.

Supporting Information can be found on Metro.com

- HCAI (OSHPD) Preapproval Document OPM-0426. OPM stands for HCAI Preapproval of Manufacturer's Certification.

- Calculations: Please contact your Metro representative.



Metro® Seismic Shelving for site approvals.

- This offering utilizes staked posts and foot plates with a single anchor hole.
- Sway braces are REQUIRED for qwikSLOT shelving units and are OPTIONAL for Super Erecta.
- Prior to purchasing these accessories please note: Metro recommends reviewing these options with the local structural engineer on your construction project to earn site approval



Super Erecta with SAFP foot plates

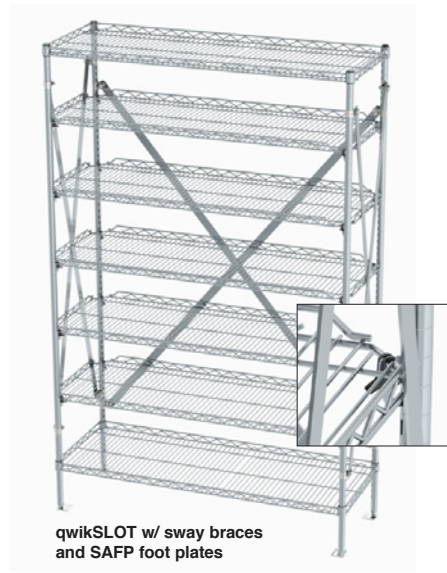

qwikSLOT w/ sway braces and SAFP foot plates

Staked Seismic Posts

- Staked post insert at the base for use with SAFP threaded seismic foot plates.
- Ordered as EACH.
- Seismic foot plates are ordered separately.

| Nominal Post Height (in.) (mm) | Actual Post Height with Seismic Foot Installed (in.) (mm) | Approx. Pkdl. Wt. (lbs.) (kg) | SES Chrome Cat. No. | SES Metroseal Green Cat. No. | SES Metroseal Gray Cat. No. | SES Stainless Cat. No. | qwikSLOT Chrome Cat. No. |
|--------------------------------|---|-------------------------------|---------------------|------------------------------|-----------------------------|------------------------|--------------------------|
| 63 1600 | 62.625 1591 | 3.5 1.6 | 63P-STKD | 63PK3-STKD | 63PK4-STKD | 63PS-STKD | 63SAPQ |
| 74 1880 | 74.6875 1897 | 4.0 1.8 | 74P-STKD | 74PK3-STKD | 74PK4-STKD | 74PS-STKD | 74SAPQ |
| 86 2184 | 86.6875 2202 | 5.0 2.3 | 86P-STKD | * | * | * | * |

NOTE: Staked posts replace older seismic post models with staked inserts (63SAP, 74SAP).
*NOTE: Contact your Metro representative for availability of 86" staked posts.



Staked Post



x4

Threaded Seismic Foot Plate Kit

ONE kit needed per shelving unit

- Kit includes four chromate plated threaded foot plates.
- Each foot plate includes a 0.687" (17mm) diameter anchor hole.
- Dimensions: 2.25" x 2.25" (57 x 57mm)

Threaded Seismic Foot Plate Kit
Cat No. SAFP
Use one kit per unit



Wall Brackets

- Optional chrome plated brackets for connecting wire shelving or Super Erecta Pro shelving to the wall for added stability.

Wall Brackets
Cat No. 9984C
Use one kit per unit



Super Erecta Single Unit

- (4) Super Erecta Shelves
- (4) staked posts
- (1) SAFP



Configuring Single qwikSLOT Shelving Units

Sway Brace End Kit - TWO are used per single unit.

- Includes braces that form an "X" on one side of the unit.

| For Shelf Depth (in.) (mm) | Approx. Pkdl. Wt. (lbs.) (kg) | Cat. No. |
|----------------------------|-------------------------------|----------|
| 18 & 21 457 & 530 | 6.0 2.7 | SA18EC |
| 24 610 | 6.1 2.8 | SA24EC |

Sway Brace Back Kit - ONE is used per single unit.

- Includes braces that form an "X" along the shelf length (back side).

| For Shelf Length (in.) (mm) | Approx. Pkdl. Wt. (lbs.) (kg) | Cat. No. |
|-----------------------------|-------------------------------|----------|
| 24 & 30 457 & 760 | 6.1 2.8 | SA24EC |
| 36 914 | 9.0 4.1 | SA36BC |
| 42 1060 | 9.2 4.2 | SA42BC |
| 48 & 54 1219 & 1370 | 9.8 4.4 | SA48BC |
| 60 1524 | 10.0 4.5 | SA60BC |

NOTE: qwikSLOT locking clips & sway braces are REQUIRED.



qwikSLOT Locking Clips Cat No. 9985QSL

Use one kit per qwikSLOT shelf

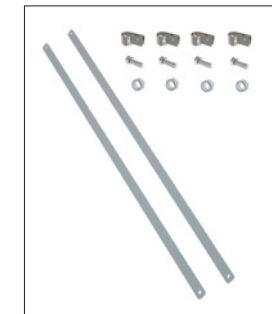

Sway Brace Back Kit



qwikSLOT Single Unit

- (2) Super Erecta Shelves
- (5) qwikSLOT Drop Mat shelves
- (5) 9985QSL locking clips
- (4) qwikSLOT seismic staked posts
- (2) Sway Brace End Kits
- (1) Sway Brace Back Kit
- (1) SAFP

Configuring Back-to-Back qwikSLOT Shelving Units

Seismic Post Clamps

- Used to connect units together for greater stability.
- Each kit contains six post clamps.
- REQUIRED for each pair of back-to-back units.

qwikSLOT Back-to-Back Unit

- (4) Super Erecta Shelves
- (10) qwikSLOT Shelves
- (10) 9985QSL locking clips
- (8) qwikSLOT seismic staked posts
- (2) Sway Brace End Kits
- (1) Sway Brace Back Kit
- (2) SAFP
- (1) SAFP (post clamp kit)

x6



Seismic Post Clamps Cat No. SACP

Use one kit per unit

NOTE: qwikSLOT locking clips & sway braces are REQUIRED.

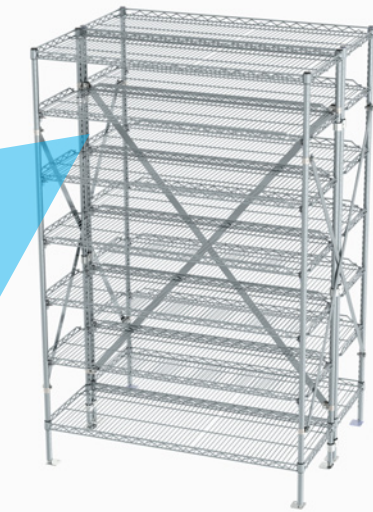

Sway Brace End Kit - TWO are used per back-to-back unit.

Includes braces that form an "X" on one side of the unit.

| For Combined Shelf Depths | Approx. Pkdl. Wt. (lbs.) (kg) | Cat. No. |
|---------------------------|-------------------------------|----------|
| Two 18" Depth. | 9.0 4.1 | SA36BC |
| One 18" & One 21" Depth | | |
| Two 21" Depth | | |
| One 18" & One 24" Depth | 9.2 4.2 | SA42BC |
| One 21" & One 24" Depth | | |
| Two 24" Depth | 9.8 4.4 | SA48BC |

Sway Brace Back Kit - ONE is used per back-to-back unit.

Includes braces that form an "X" along the shelf length (back side).

| For Shelf Length (in.) (mm) | Approx. Pkdl. Wt. (lbs.) (kg) | Cat. No. |
|-----------------------------|-------------------------------|----------|
| 24 & 30 610 & 760 | 6.1 2.8 | SA24EC |
| 36 914 | 9.0 4.1 | SA36BC |
| 42 1060 | 9.2 4.2 | SA42BC |
| 48 & 54 1219 & 1370 | 9.8 4.4 | SA48BC |
| 60 1524 | 10.0 4.5 | SA60BC |

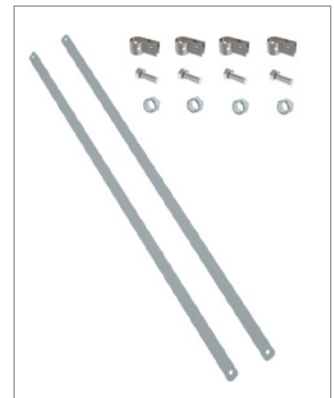

Every
process
optimized.
Every
item within
reach.



SmartWall®

WALL SHELVING





| | |
|--------------------------------------|---------|
| Wall Shelving | 118-130 |
| SmartWall Grid & Wall Shelving | 120-127 |
| Wall Mounted Shelving | 128-130 |



Wall-to-wall efficiency.

A unique storage and workstation system for often underutilized wall space.

Perfect for:

-  Prep Areas
-  Storage Rooms
-  Janitorial Supply
-  Above Sinks, Worktables or Equipment

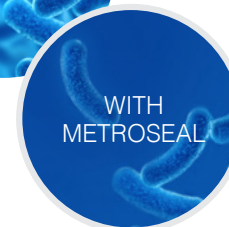
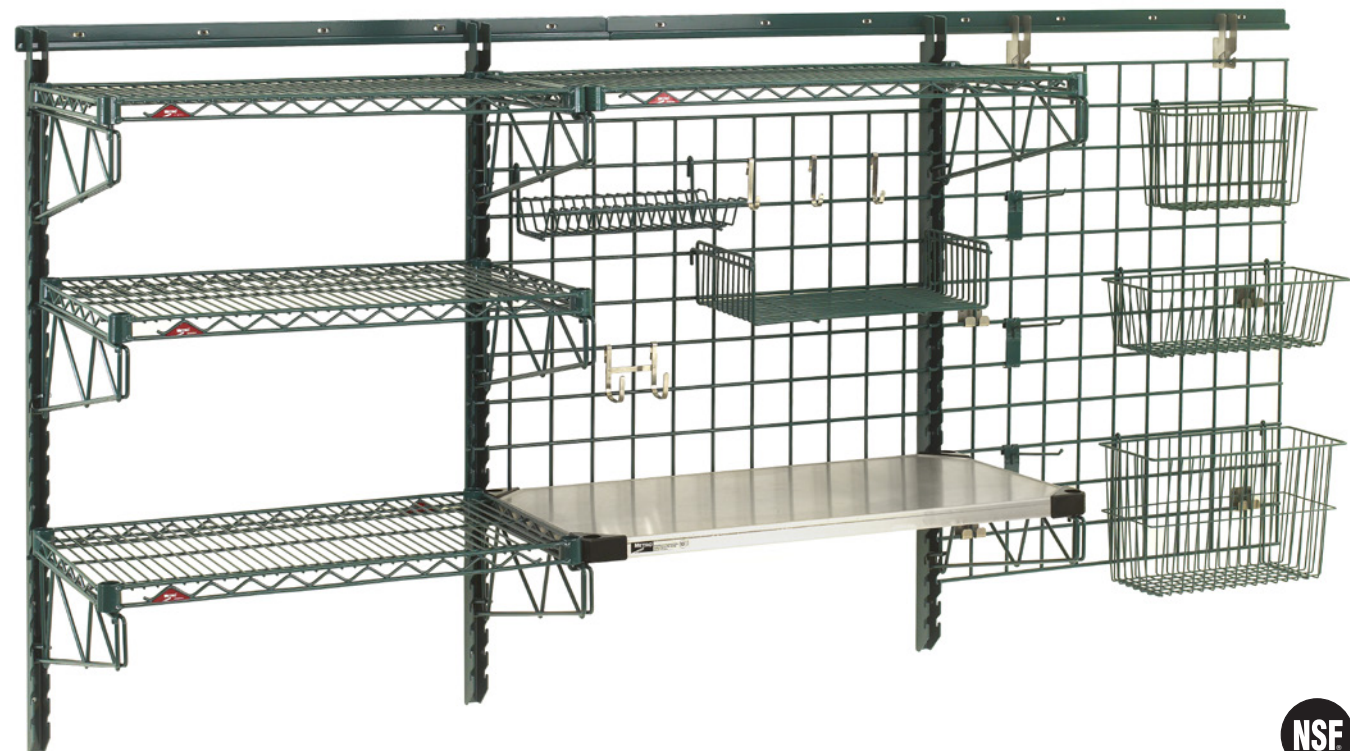

Green Metroseal Epoxy Finish with Microban



Gray Metroseal Epoxy Finish with Microban

Flexible, Robust Design:

Wall tracks and uprights are designed to interface with wood studs, plywood, concrete, and other suitable wall structures.

Easy to Adapt:

Uprights and grid brackets can be easily repositioned along the track before being fastened to the wall. Shelves and accessories are easy to add and remove.

Easy to Install:

Once the tracks are installed level, shelving and task stations can be quickly configured.

Easy to Clean:

Shelves, shelf supports, and grids can easily be removed for thorough cleaning of walls. Wall tracks and uprights can easily be wiped clean.

Durable Finishes:

Super Erecta with Metroseal Green & Gray epoxy finishes for all environments with built-in Microban® antimicrobial product protection.





Easy Order Starter Kits

Medium-Duty Task Station — {10.42b}

Cat. No. SWK36-1

(1) Wall Track, (2) Uprights (1) Super Erecta Shelf, (2) Single Shelf Supports, (1) Wire Grid

Overall dimensions: 40" L x 31¹/₄" H (1016 x 793mm)

Shelf Size: 18" x 36" (457 x 914mm)

Grid Size: 18" x 36" (457 x 914mm)



Standard-Duty Task Station — {10.42b}

Cat. No. SWK36-2

(1) Wall Track, (2) Grid Brackets (1) Grid Shelf, (1) Wire Grid

Overall dimensions: 40" L x 39¹/₁₆" H (1016 x 1008mm)

Shelf Size: 18" x 36" (457 x 914mm)

Grid Size: 30" x 36" (762 x 914mm)

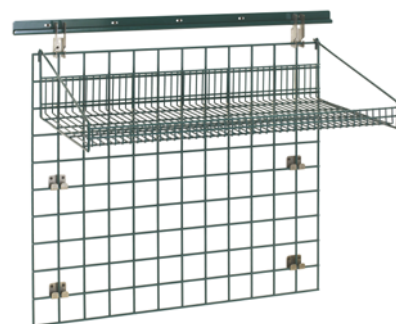

Easy Order Accessory Packs

Accessory Pack Sink — {10.42b}

Cat. No. SWA1

(1) Wire Basket, (1) Lid Holder, (1) Utensil Cylinder, (1) Cylinder Holder, (2) Prong Hooks, (6) Standard Hooks

Accessories fit: 18" x 36" (457 x 914mm) of grid space



Wire Grid and Grid Brackets Not Included.

Accessory Pack Prep — {10.42b}

Cat. No. SWA2

(1) Small Shelf, (1) Wire Basket, (1) Bin Holder, (1) Small Bin, (2) Prong Hooks, (6) Standard Hooks

Accessories fit: 18" x 36" (457 x 914mm) of grid space



Wire Grid and Grid Brackets Not Included.



Easy Order Application Kits Includes Accessories Shown

Complete Smartwall Sink Unit

Cat. No. SWK36-1A1-SR

(1) Wall Track, (2) Uprights (1) Super Erecta Shelf, (2) Single Shelf Supports, (2) Prong Hooks, (4) Small Hooks, (1) Wire Basket, (1) Drying Shelf, (1) Utensil Holder



Packaged in One Box

SmartWall Dish Tank Unit

Cat. No. CR3COMP72

(2) Wall Tracks, (4) Uprights, (4) Single Shelf Supports, (2) Metroseal Green Super Erecta Pro Shelves, (2) Metroseal Green Wire Grids, (2) Lid Storage Racks, (6) Cylinder Holders, (2) Deep Storage Baskets, (12) Prong Hooks



Packaged in One Box

Pizza Prep SmartWall Unit

Cat. No. SWKIT-PIZZAPREP

(1) Metroseal Gray Wire Grid, (1) Wall Track, (2) Uprights, (2) Shelf Supports, (1) Metroseal Gray Super Erecta Shelf, (1) Bottle Holder, (1) 1/3 Pan Holder, (1) Spice Rack, (1) Glove Box Holder, (1) Light Duty Shelf, (4) Prong Hooks

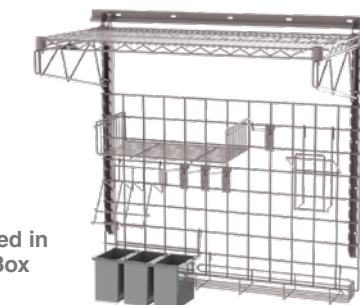

Packaged in One Box

Complete Smartwall Prep Unit

Cat. No. CR36SWPREP

(1) Wall Track, (2) Uprights, (1) Metroseal Green Wire Grid, (2) Single Shelf Supports, (1) Metroseal Green Super Erecta Shelf, (1) Drying Shelf, (2) Storage Baskets, (1) Utensil Cylinder, (1) Cylinder Holder, (6) Prong Hooks, (2) Standard Hooks



Packaged in One Box

Complete Smartwall Prep Unit 2

Cat. No. SWK36-1A2-SR

(1) Wall Track, (2) Uprights (1) Super Erecta Shelf, (2) Single Shelf Supports, (2) Prong Hooks, (4) Small Hooks, (1) Wire Basket, (1) Shelf (1) Clear Bin (Blue Bins are Discontinued)

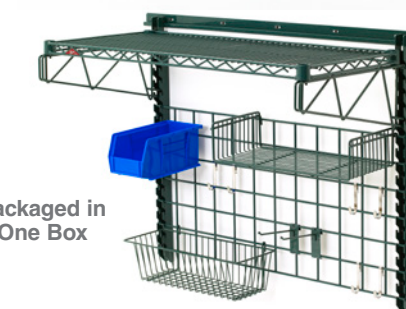

Packaged in One Box



TRY NOW >>

Easily customize & specify SmartWall in 3D.



Configuring Basic Task Stations



SMART WALL ASSEMBLY

Selecting Wall Tracks

Wall track or combination of tracks must be at least 2" (51mm) longer than the desired span of shelves. 1" (25mm) on each end of the span of tracks is reserved for hardware that acts as a stop. (Example: If 152" (3860mm) of wall track could be mounted, then the length of a shelf tier cannot exceed 150" (3810mm).

Grids

Grids may attach directly to the uprights. Grids may not overhang the uprights by more than 6" (152mm). When uprights are not used, select the appropriate grid bracket kit based on the configuration.

Configuring Basic Wall Shelving

Selecting Wall Tracks.

Wall track or combination of tracks must be at least 2" (51mm) longer than the desired span of shelves. 1" (25mm) on each end of the span of tracks is reserved for hardware that acts as a stop. (Example: If 152" (3860mm) of wall track could be mounted, then the length of a shelf tier cannot exceed 150" (3810mm).

Uprights.

- 15" (381mm) uprights: 1 shelf tier maximum
- 30" (762mm) uprights: 3 shelf tiers maximum
- 45" (1143mm) uprights: 4 shelf tiers maximum

Uprights and Shelf Supports

Enable standard Super Erecta, Super Erecta Pro, MetroMax Q, and MetroMax i shelves to be used as part of the task station.

Combinations of Grids and Shelves

Grids can be mounted directly behind shelves, but shelf supports and grids cannot occupy the same slots on the upright. Once the grid has been mounted to the upright, the shelf support can be mounted to its own slots and can be adjusted on 3" (76mm) increments within the grid space.

Shelves.

When configuring side-by-side shelving units, the adjacent shelves on the same tier must have the same depth. Minimum space between shelf tiers is 9" (229mm).

Note: When using MetroMax i shelves with SmartWall shelf supports, order one adapter kit per shelf (Cat. No. M9997-4).

Shelf Supports.

Order to match up with the depth of the shelf.



SmartWall Components — {10.42}

Wall Tracks (minimum one per system)

Joiner plates and stop fastener hardware included. Does not include hardware to mount wall tracks to the wall.



| Actual Length (in.) (mm) | Actual Depth (in.) (mm) | Actual Width (in.) (mm) | Approx. Pkd. Wt. (lbs.) (kg) | Cat. No. Metroseal Gray | Cat. No. Metroseal Green |
|--------------------------|-------------------------|-------------------------|------------------------------|-------------------------|--------------------------|
| 40 1016 | .75 19 | 1.56 40 | 5.0 2.2 | SW40K4 | SW40K3 |
| 56 1423 | .75 19 | 1.56 40 | 6.0 2.6 | SW56K4 | SW56K3 |
| 72 1829 | .75 19 | 1.56 40 | 7.0 3.1 | SW72K4 | SW72K3 |

*Note: Tracks can be cut to length, but Metro does not provide this service. Touch-up paint for Metroseal Green & Gray tracks is available.

Replacement Joiner Plate Hardware

Cat. No. RPTRK-HDWE

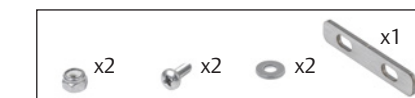

Uprights (For medium-duty applications, minimum two per system. Sold by the piece)

Built-in slots allow shelf supports and grids to attach without tools or hardware. 1.5" (38mm) slot spacing allows shelves and grids to be adjusted on 1.5" (38mm) increments

| Cat. No. Metroseal Green | Cat. No. Metroseal Gray | Number of slots | Actual Length (in.) (mm) | Actual Width (in.) (mm) | Actual Depth (in.) (mm) |
|--------------------------|-------------------------|-----------------|--------------------------|-------------------------|-------------------------|
| SWU15K3 | SWU15K4 | 7 | 16 406 | 1.13 29 | 1.88 48 |
| SWU30K3 | SWU30K4 | 17 | 31 787 | 1.13 29 | 1.88 48 |
| SWU45K3 | SWU45K4 | 26 | 44.5 1130 | 1.13 29 | 1.88 48 |
| - | SWU72K4 | 45 | 71.5 787 | 1.13 29 | 1.88 48 |
| - | SWU85K4 | 54 | 84.5 1130 | 1.13 29 | 1.88 48 |

Shelf Supports (Sold by the piece)

Mount directly to slotted uprights. Suitable for use with Super Erecta, MetroMax Q, MetroMax i shelves.

Single shelf supports are used on each end of a single unit or side-by-side unit. Double (intermediate) shelf supports are used when configuring side-by-side wall shelving units.

Single Shelf Supports

| Fits shelf depth | Actual Length (in.) (mm) | Actual Width (in.) (mm) | Actual Height (in.) (mm) | Approx. Pkd. Wt. (lbs.) (kg) | Cat. No. Metroseal Gray | Cat. No. Metroseal Green |
|------------------|--------------------------|-------------------------|--------------------------|------------------------------|-------------------------|--------------------------|
| 14" (355mm) | 16.56 421 | 1.5 38 | 8.19 208 | 2.5 1.1 | SWS14K4 | SWS14K3 |
| 18" (457mm) | 20.56 522 | 1.5 38 | 8.19 208 | 3.0 1.3 | SWS18K4 | SWS18K3 |
| 21" (530mm) | 23.56 598 | 1.5 38 | 8.19 208 | 3.5 1.5 | SWS21K4 | SWS21K3 |
| 24" (610mm) | 26.56 675 | 1.5 38 | 8.19 208 | 3.5 1.5 | SWS24K4 | SWS24K3 |

*Note: Replacement plastic sleeve for shelf support. Cat. No. RP-SPSLV.
Note: When using MetroMax i shelves with shelf supports, please order 1 adapter kit per shelf. Cat. No. M9997-4

Double (Intermediate) Shelf Supports

| Fits shelf depth | Actual Length (in.) (mm) | Actual Width (in.) (mm) | Actual Height (in.) (mm) | Approx. Pkd. Wt. (lbs.) (kg) | Cat. No. Metroseal Gray | Cat. No. Metroseal Green |
|------------------|--------------------------|-------------------------|--------------------------|------------------------------|-------------------------|--------------------------|
| 14" (355mm) | 16.56 421 | 1.5 38 | 8.19 208 | 2.5 1.1 | SWD14K4 | SWD14K3 |
| 18" (457mm) | 20.56 522 | 1.5 38 | 8.19 208 | 3.0 1.3 | SWD18K4 | SWD18K3 |
| 21" (530mm) | 23.56 598 | 1.5 38 | 8.19 208 | 3.5 1.5 | SWD21K4 | SWD21K3 |
| 24" (610mm) | 26.56 675 | 1.5 38 | 8.19 208 | 3.5 1.5 | SWD24K4 | SWD24K3 |

*Note: Replacement plastic sleeve for shelf support. Cat. No. RP-SPSLV.
Note: When using MetroMax i shelves with shelf supports, please order 1 adapter kit per shelf. Cat. No. M9997-4

Grid Mounting Brackets (for standard-duty applications without uprights)

- Use to connect the grid to the wall when uprights are not used. One kit required per grid.

| Description | Approx. Pkd. Wt. (lbs.) (kg) | Cat. No. |
|--|------------------------------|----------|
| Bracket kit to connect grid to wall track; includes (2) top and (4) bottom (stainless steel) | 2.0 0.9 | SWGB1 |
| Direct wall mount bracket kit; consists of (6) bottom brackets (stainless steel) | 2.0 0.9 | SWGB2 |
| Direct wall mount bracket kit; consists of (6) black plastic brackets | 2.0 0.9 | WGBRKT |

Wire Grids

- Brackets to mount the grid to the wall track or the wall are not included and can attach directly to uprights without brackets or tools.
- Grid openings measure approximately 3" x 3" (76 x 76mm)

| Width x Length (in.) (mm) | Cat. No. Plated | Cat. No. Metroseal Green | Cat. No. Metroseal Gray |
|---------------------------|-----------------|--------------------------|-------------------------|
| 18x30 457x760 | — | WG1830K3 | WG1830K4 |
| 18x36 457x914 | WG1836BR | WG1836K3 | WG1836K4 |
| 18x48 457x1219 | WG1848BR | WG1848K3 | WG1848K4 |
| 18x60 457x1524 | WG1860BR | WG1860K3 | WG1860K4 |
| 24x36 610x914 | — | WG2436K3 | WG1836K4 |
| 24x48 610x1219 | — | WG2448K3 | WG1848K4 |
| 30x36 760x914 | — | WG3036K3 | WG1836K4 |
| 30x48 760x1219 | — | WG3048K3 | WG1848K4 |
| 33x54 838x1370 | PBA-GPC | — | — |

*Note: Can be retrofitted to original MetroMax and MetroMax Q shelving.

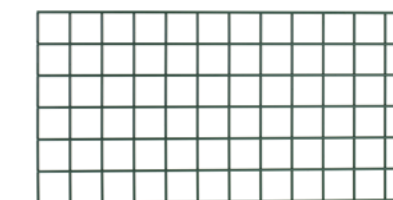

Grid: 18" x 36" (457 x 914mm)

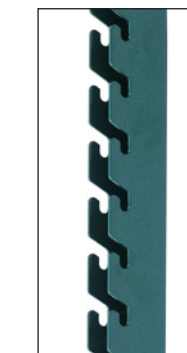

Single Support



Double (intermediate) Support

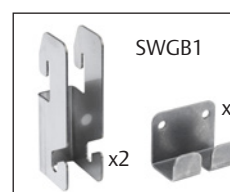



Tray Drying Rack
TDR48K3
For use with 1/2 size bun pans & steam pan lids, small service trays.



Pan Holder (Pan Not included)
STP3BR (Brite)
STP3K4 (Gray)



Sticker Roll/Paper Towel Holder
SRD15K3 (Green)
SRD15K4 (Gray)



Utility Shelf
SR24BR



Prong Hook
PGHK6K3 (Green)
PGHK6K4 (Gray)



Light-Duty Shelf
PBA-GSDK3 (Green)
PBA-GSDK4 (Gray)



Slanted Lid Holder / Drying Shelf
IWA-S11K3 (Green)
IWA-S11K4 (Gray)
For use with 1/2 and 1/3 size lids.



Lid Holder / Drying Shelf
IWA-11K3 (Green)
IWA-11K4 (Gray)
For use with 1/6 and 1/9 size lids.



Large Utensil Holder
IWA-12K3 (Green)
IWA-12K4 (Gray)



Double Large Hooks
HK26C



Large Hook
HK25C



Small Hook
HK23C



Small Basket
H209K3 (Green)
H209K4 (Gray)



Large 5" Deep Basket
H210K3 (Green)
H210K4 (Gray)



Shelf with Retaining Ledge: 14" (356mm) x 36" (895mm) Shown
GS11436K3 (Green)
GS11436K4 (Gray)



Grid Shelf
FGS1224K3 (Green)
FGS1224K4 (Gray)



Glove Box Holder (Vertical)
GBHVK3 (Green)
GBHVK4 (Gray)



Cylinder Holder
FCH
White Utensil Cylinder
FC1

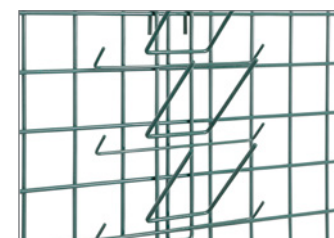

6 Prong Bottle Holder
BH6K3 (Green)
BH6K4 (Gray)



Bin Holder
Single 3" (76mm): **DD3722A**
Small 11" (280mm): **PBA-1BH**
Large 22" (559mm): **PBA-2BH**



Large 10" Deep Basket
H212K3 (Green)
H212K4 (Gray)



Hanging File Holder
PBA-PFH (Chrome)

Accessories for Grids — {10.42}

| Shelves | Dimensions (in) | Dimensions (mm) | Cat. No. Metroseal Green | Cat. No. Metroseal Gray |
|---|----------------------|------------------|--------------------------|-------------------------|
| 14"x36" (356 x 914mm) Shelf w/Retaining Edge | 15.38 x 35.25 x 7.75 | 391 x 895 x 197 | GS1436K3 | GS1436K4 |
| 14"x48" (356 x 1219mm) Shelf w/Retaining Edge | 15.38 x 47.25 x 7.75 | 391 x 1200 x 197 | GS1448K3 | GS1448K4 |
| 18"x30" (457 x 762mm) Shelf w/Retaining Edge | 19.38 x 29.25 x 7.75 | 492 x 743 x 197 | GS1830K3 | GS1830K4 |
| 18"x36" (457 x 914mm) Shelf w/Retaining Edge | 19.38 x 35.25 x 7.75 | 492 x 895 x 197 | GS1836K3 | GS1836K4 |
| 18"x48" (457 x 1219mm) Shelf w/Retaining Edge | 19.38 x 47.25 x 7.75 | 492 x 1200 x 197 | GS1848K3 | GS1848K4 |
| Light-Duty Shelf with Side Ledges | 9 W x 18.5 L | 288 W x 470 L | PBA-GSDK3 | PBA-GSDK4 |
| Flat Grid Shelf 24" (610mm) | 12.69 x 24 x 4 | 322 x 610 x 102 | FGS1224K3 | FGS1224K4 |

| Hooks | Dimensions (in) | Dimensions (mm) | Cat. No. Metroseal Green | Cat. No. Metroseal Gray | Cat. No. Chrome |
|-----------------------|--------------------|-----------------|--------------------------|-------------------------|-----------------|
| Small Hook | 1.25 x 3.5 | 32 x 89 | - | - | HK23C |
| Large Hook | 2 x 3.5 | 50 x 89 | - | - | HK25C |
| Double Large Hook | 2 x 3.5 | 50 x 89 | - | - | HK26C |
| 6" (152mm) Prong Hook | 1.25 x 7.63 x 5.63 | 32 x 194 x 92 | PGHK6K3 | PGHK6K4 | - |

| Baskets | Dimensions (in) | Dimensions (mm) | Cat. No. Metroseal Green | Cat. No. Metroseal Gray |
|-------------------------------|------------------|-----------------|--------------------------|-------------------------|
| Small Basket | 13.38 x 5 x 7 | 345 x 127 x 180 | H209K3 | H209K4 |
| 5" (127mm) Deep Large Basket | 17.38 x 7.5 x 5 | 440 x 190 x 127 | H210K3 | H210K4 |
| 10" (254mm) Deep Large Basket | 17.38 x 7.5 x 10 | 440 x 190 x 255 | H212K3 | H212K4 |

| Bins & Bin Holders | Dimensions (in) | Dimensions (mm) | Cat. No. Metroseal Green | Cat. No. Metroseal Gray |
|------------------------------|-------------------|-----------------|--------------------------|-------------------------|
| Clear Bin Packed 12/Ctn. | 10.88 x 5.5 x 5 | 279 x 140 x 127 | - | MB30230CLSH |
| Clear Bin Packed 6/Ctn. | 10.88 x 11 x 5 | 279 x 280 x 127 | - | MB30235CLSH |
| Clear Bin Packed 12/Ctn. | 14.75 x 8 1/4 x 7 | 375 x 210 x 180 | - | MB30240CLSH |
| 3" (76mm) Single Bin Holder | 3 x 3 | 76 x 76 | - | DD3722A |
| 11" (280mm) Small Bin Holder | 11 x 3 | 280 x 76 | - | PBA-1BH |
| 22" (559mm) Large Bin Holder | 22 x 3 | 559 x 76 | - | PBA-2BH |

| Drying Rack Accessories | Dimensions (in) | Dimensions (mm) | Cat. No. Metroseal Green | Cat. No. Metroseal Gray |
|-----------------------------------|-----------------------|------------------|--------------------------|-------------------------|
| Slanted Lid Holder / Drying Shelf | 14.13 x 20.75 x 12.13 | 359 x 527 x 307 | IWA-S11K3 | IWA-S11K4 |
| Lid Holder / Drying Shelf | 8.25 x 13.5 x 4.5 | 210 x 343 x 114 | IWA-11K3 | IWA-11K4 |
| Tray Drying Rack | 14.56 x 46.25 x 10.19 | 371 x 1175 x 259 | TDR48K3 | TDR48K4 |
| 6-prong Bottle Holder | 14.63 x 5.13 x 11 | 378 x 130 x 279 | BH6K3 | BH6K4 |

| Utensil Holder | Dimensions (in) | Dimensions (mm) | Cat. No. Metroseal Green | Cat. No. Metroseal Gray |
|------------------------------------|--------------------|-----------------|--------------------------|-------------------------|
| Large Utensil Holder | 10.5 x 10.38 x 4 | 267 x 264 x 102 | IWA-12K3 | IWA-12K4 |
| Small Utensil Holder | 4.38 x 10.38 x 4 | 111 x 264 x 102 | IWA-14K3 | IWA-14K4 |
| White Flatware/Instrument Cylinder | 4.31 x 4.31 x 5.5 | 109 x 109 x 140 | FC1 | FC1 |
| Cylinder Holder | 2.63 x 5.88 x 5.75 | 67 x 149 x 146 | FCH | FCHK4 |

| Miscellaneous Accessories | Dimensions (in) | Dimensions (mm) | Cat. No. Metroseal Green | Cat. No. Metroseal Gray | Cat. No. Chrome |
|-----------------------------------|---|-----------------|--------------------------|-------------------------|-----------------|
| Utility Shelf / Spice Rack | 10.88 x 5.5 x 5 | 279 x 140 x 127 | SR24K3 | SR24K4 | - |
| Insert Pan Holder | 10.88 x 11 x 5 | 279 x 280 x 127 | STP3K4 | - | STP3BR |
| Hanging File Holder | 14.75 x 8.25 x 7 | 375 x 210 x 180 | - | - | PBA-PFH |
| Glove Box Holder (Vertical) | Inside Dimensions 5.88" Wx3.44" D [267mm Wx87mm D] | | GBHVK3 | GBHVK4 | - |
| Glove Box Holder (Horizontal) | Inside Dimensions 10.125" Wx3.44" D [259mm Wx87mm D] | | - | GBHHK4-S | - |
| Sticker Roll / Paper Towel Holder | Overall Dimensions (Width/Length/Height): 5" x 18.25" x 3.75" (127 x 470 x 95mm) Note: Tube dimension for holding rolls: 14.75" (375mm). Fits up to 6.25" (159mm) diameter | | SRD15K3 | SRD15K4 | - |



Wall Mounts

- An ideal method for storing items overhead or above work surfaces.
- Brackets accommodate all Super Erecta® sizes and types of shelves.
 - Use double supports to mount adjacent shelves, single supports at ends.
 - Metal caps to cover openings are provided.
 - Available in chrome, Metroseal Gray, Metroseal Green or stainless steel.

Post-Type Wall Mounts — {10.40}

Standard Units

Post-type wall mounts are available in pre-packaged “End Units” and “Mid Units”; complete with all needed components except shelves, wall bolts or screws, which must be selected according to type of wall.

A “End Unit” consists of two posts with wall mounting brackets, and two single shelf supports for each shelf level.

B “Mid Unit” consists of one post with brackets and double support for each shelf.

Note: If shelving is to be the length of one shelf, order End Unit only.

If two-shelf lengths, order one End Unit and one Mid Unit; three lengths, one End and two Mid Units; four lengths, one End and three Mid Units; etc.

For 14" (355mm) Shelf Width

| Shelf Levels | Approx. Pkd. Wt. (lbs.) | Approx. Pkd. Wt. (kg) | Cat. No. End Unit | Approx. Pkd. Wt. (lbs.) | Approx. Pkd. Wt. (kg) | Cat. No. Mid Unit |
|--------------|-------------------------|-----------------------|-------------------|-------------------------|-----------------------|-------------------|
| 1 | 7 | 3.2 | SW21C | 5 | 2.3 | AW21C |
| 2 | 14 | 6.4 | SW23C | 9 | 4.1 | AW23C |
| 3 | 22 | 10 | SW25C | 14 | 6.4 | AW25C |
| 4 | 28 | 12.7 | SW26C | 18 | 8.2 | AW26C |

For 18" (457mm) Shelf Width

| Shelf Levels | Approx. Pkd. Wt. (lbs.) | Approx. Pkd. Wt. (kg) | Cat. No. End Unit | Approx. Pkd. Wt. (lbs.) | Approx. Pkd. Wt. (kg) | Cat. No. Mid Unit |
|--------------|-------------------------|-----------------------|-------------------|-------------------------|-----------------------|-------------------|
| 1 | 7 | 3.2 | SW31C | 5 | 2.3 | AW31C |
| 2 | 14 | 6.4 | SW33C | 11 | 5 | AW33C |
| 3 | 22 | 10 | SW35C | 17 | 8 | AW35C |
| 4 | 28 | 12.7 | SW36C | 21 | 9.5 | AW36C |

For 21" (530mm) Shelf Width

| Shelf Levels | Approx. Pkd. Wt. (lbs.) | Approx. Pkd. Wt. (kg) | Cat. No. End Unit | Approx. Pkd. Wt. (lbs.) | Approx. Pkd. Wt. (kg) | Cat. No. Mid Unit |
|--------------|-------------------------|-----------------------|-------------------|-------------------------|-----------------------|-------------------|
| 1 | 8 | 3.6 | SW41C | 6 | 2.7 | AW41C |
| 2 | 16 | 7.3 | SW43C | 12 | 5.5 | AW43C |
| 3 | 25 | 11.3 | SW45C | 18 | 8.2 | AW45C |
| 4 | 32 | 14.4 | SW46C | 23 | 10.4 | AW46C |

For 24" (610mm) Shelf Width

| Shelf Levels | Approx. Pkd. Wt. (lbs.) | Approx. Pkd. Wt. (kg) | Cat. No. End Unit | Approx. Pkd. Wt. (lbs.) | Approx. Pkd. Wt. (kg) | Cat. No. Mid Unit |
|--------------|-------------------------|-----------------------|-------------------|-------------------------|-----------------------|-------------------|
| 1 | 9 | 4.1 | SW51C | 6 | 2.7 | AW51C |
| 2 | 18 | 8.2 | SW53C | 12 | 5.5 | AW53C |
| 3 | 28 | 12.7 | SW55C | 19 | 9 | AW55C |
| 4 | 36 | 16 | SW56C | 24 | 10.9 | AW56C |

***Note:** User should determine that wall material and method of mounting are suitable to support the shelves and their contents. Mounting hardware not included.

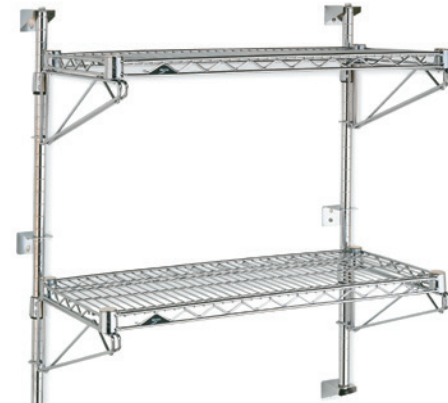

Post-Type Wall Mount Installation
*Shelf supports are chrome-plated.

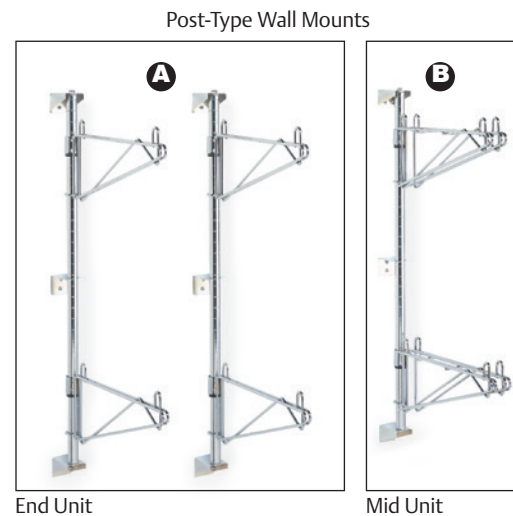

Maximum Load Rating: 250 lbs. (113kg) per shelf, not to exceed 250 lbs. (113kg) per unit.

Metro Tip:

Have you looked at your walls lately? Unused wall space provides the perfect opportunity for a significant increase in storage capacity. Metro offers a complete line of wall shelving systems to maximize storage density.

See page 48 for Super Erecta shelves.



Posts and Brackets — {10.40}

Two end brackets (BES) are supplied with each of these double-footed posts. One intermediate bracket (BCS) is supplied with 33PDF posts and two are supplied with 54PDF and 63PDF posts. Order desired number/style of shelf supports below.

| Post Height (in.) (mm) | Description | Approx. Pkd. Wt. (lbs.) (kg) | Cat. No. Chrome | Cat. No. Metroseal Green with Microban® | Cat. No. Metroseal Gray with Microban® | Cat. No. Stainless |
|------------------------|--------------------------|------------------------------|-----------------|---|--|--------------------|
| 13.88 350 | Post for 1 tier | 1.25 0.6 | 13PDF | 13PDFK3 | 13PDFK4 | 13PDFS |
| 33.63 854 | Post for 2 tiers | 2.75 1.2 | 33PDF | 33PDFK3 | 33PDFK4 | 33PDFS |
| 54 1370 | Post for 3 or more tiers | 5 2.3 | 54PDF | 54PDFK3 | 54PDFK4 | 54PDFS |
| 62 1573 | Post for 4 or more tiers | 6 2.7 | 63PDF | 63PDFK3 | 63PDFK4 | 63PDFS |
| | End Bracket | .5 0.2 | BES | BESK3 | BESK4 | SBES |
| | Intermediate Bracket | .5 0.2 | BCS | BCSK3 | BCSK4 | SBCS |

Note: User should determine that wall material and method of mounting are suitable to support the shelves and their contents.

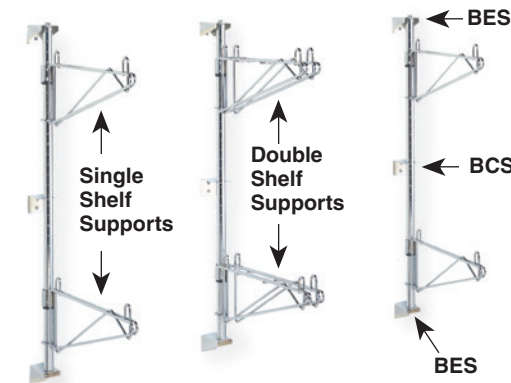

Maximum Load Rating: 250 lbs. (113kg) per shelf, not to exceed 250 lbs. (113kg) per unit.

See page 48 for Super Erecta shelves.

Typical configuration using two end units and one mid unit

Shelf Supports — Post Mounting — {10.40}

Single — Two required per shelf (one at each end.)

| Shelf Width (in.) (mm) | Approx. Pkd. Wt. (lbs.) (kg) | Cat. No. Chrome | Cat. No. Metroseal Green with Microban® | Cat. No. Metroseal Gray with Microban® | Cat. No. Stainless |
|------------------------|------------------------------|-----------------|---|--|--------------------|
| 14 355 | 2 0.9 | 1WS14C | 1WS14K3 | 1WS14K4 | 1WS14S |
| 18 457 | 2 0.9 | 1WS18C | 1WS18K3 | 1WS18K4 | 1WS18S |
| 21 530 | 2.5 1.1 | 1WS21C | | | 1WS21S |
| 24 610 | 3 1.4 | 1WS24C | 1WS24K3 | 1WS24K4 | 1WS24S |

Double — For run of multiple shelves.

| Shelf Width (in.) (mm) | Approx. Pkd. Wt. (lbs.) (kg) | Cat. No. Chrome | Cat. No. Metroseal Green with Microban® | Cat. No. Metroseal Gray with Microban® | Cat. No. Stainless |
|------------------------|------------------------------|-----------------|---|--|--------------------|
| 14 355 | 3 1.4 | 2WS14C | 2WS14K3 | 2WS14K4 | 2WS14S |
| 18 457 | 3.75 1.7 | 2WS18C | 2WS18K3 | 2WS18K4 | 2WS18S |
| 21 530 | 4.25 1.9 | 2WS21C | | | 2WS21S |
| 24 610 | 4.5 2.0 | 2WS24C | 2WS24K3 | 2WS24K4 | 2WS24S |

Order shelves from page 48.

Direct Wall Mounts — {10.40}

Each consists of one shelf support and mounting plate, with two shelf collar caps. Use single support at shelf ends; double support for adjoining shelves.

Single — Two required per shelf

| Shelf Width (in.) (mm) | Approx. Pkd. Wt. (lbs.) (kg) | Cat. No. Chrome | Cat. No. Metroseal Green with Microban® | Cat. No. Metroseal Gray with Microban® | Cat. No. Stainless |
|------------------------|------------------------------|-----------------|---|--|--------------------|
| 14 355 | 1.5 0.7 | 1WD14C | 1WD14K3 | 1WD14K4 | 1WD14S |
| 18 457 | 2 0.9 | 1WD18C | 1WD18K3 | 1WD18K4 | 1WD18S |
| 21 530 | 2 0.9 | 1WD21C | 1WD21K3 | 1WD21K4 | 1WD21S |
| 24 610 | 2.25 1.0 | 1WD24C | 1WD24K3 | 1WD24K4 | 1WD24S |

Double

| Shelf Width (in.) (mm) | Approx. Pkd. Wt. (lbs.) (kg) | Cat. No. Chrome | Cat. No. Metroseal Green with Microban® | Cat. No. Metroseal Gray with Microban® | Cat. No. Stainless |
|------------------------|------------------------------|-----------------|---|--|--------------------|
| 14 355 | 3 1.4 | 2WD14C | 2WD14K3 | 2WD14K4 | 2WD14S |
| 18 457 | 3 1.4 | 2WD18C | 2WD18K3 | 2WD18K4 | 2WD18S |
| 21 530 | 4 1.8 | 2WD21C | 2WD21K3 | 2WD21K4 | 2WD21S |
| 24 610 | 4.5 2.0 | 2WD24C | 2WD24K3 | 2WD24K4 | 2WD24S |

Note: User should determine that wall material and method of mounting are suitable to support the shelves and their contents.



Single Shelf Support



Double Shelf Support



Hole Plugs — {10.06}

This chrome-plated cover is used to fill shelf-corner openings. Use wherever posts have been eliminated by “S” hooks.

Cat. No. 9997C

Corner Adapters for MetroMax i shelving

Use when joining MetroMax i shelves with wire shelf supports. Box of 4. Use one box per shelf.

Cat. No. M9997-4

Corner Adapters for MetroMax 4 shelving

Use when joining MetroMax 4 shelves with wire shelf supports. Box of 4. Use one box per shelf.

Cat. No. MAX4-9997-4

Metro Tip:

MetroMax Q, MetroMax 4, and MetroMax i shelves can be used with Super Erecta Post Mounting Shelf Supports and Direct Wall Mounts.

ERECTA SHELF®/METROMAX® i WALL SHELVING



Direct Wall Mount Shelving — {10.40}

Use standard Super Erecta stainless steel direct wall mount shelf supports with MetroMax shelves or open frames with wire drop in baskets. Order one MetroMax corner adapter kit with each shelf or shelf frame. Shelf supports are sold individually.

Single — Use at shelf ends; two are required for a stand-alone shelf.

| Shelf Width (in.) | Shelf Width (mm) | Approx. Pkd. Wt. (lbs.) | Approx. Pkd. Wt. (kg) | Cat. No. Stainless Steel |
|-------------------|------------------|-------------------------|-----------------------|--------------------------|
| 18 | 457 | 2 | 0.9 | 1WD18S |
| 24 | 610 | 2.25 | 1.0 | 1WD24S |

Double — When constructing a run of shelves, use double shelf supports to join adjacent shelves.

| Shelf Width (in.) | Shelf Width (mm) | Approx. Pkd. Wt. (lbs.) | Approx. Pkd. Wt. (kg) | Cat. No. Stainless Steel |
|-------------------|------------------|-------------------------|-----------------------|--------------------------|
| 18 | 457 | 3 | 1.4 | 2WD18S |
| 24 | 610 | 4.25 | 2.0 | 2WD24S |

For MetroMax i Open Frame and Drop-In Basket, see page 29.

Corner Adapters for MetroMax i shelving

Use when joining MetroMax i shelves with wire shelf supports. Box of 4. Use one box per shelf. **Cat. No. M9997-4**

Corner Adapters for MetroMax 4 shelving

Use when joining MetroMax 4 shelves with wire shelf supports. Box of 4. Use one box per shelf. **Cat. No. MAX4-9997-4**

Erecta Shelf® Wall Mounts — {10.56}

Used to create wall-mounted shelving units with 12" (305mm) or 18" (457mm) Erecta shelves of any length.

- Models are available to accommodate from one to five shelves. (Each mount consists of two shelf supports and mounting brackets.)
- Wall bolts or screws not included; they must be selected according to type of wall.
- Order shelves from page 77.

| Width (in.) | Width (mm) | Height (in.) | Height (mm) | Capacity | Approx. Pkd. Wt. (lbs.) | Approx. Pkd. Wt. (kg) | Cat. No. Chrome |
|-------------|------------|--------------|-------------|----------------|-------------------------|-----------------------|-----------------|
| 12 | 305 | 10.75 | 273 | 1 Shelf | 2.5 | 1.1 | 12WB1C |
| 12 | 305 | 20.81 | 528 | 1 to 3 Shelves | 5 | 2.3 | 12WB3C |
| 12 | 305 | 30.81 | 782 | 1 to 5 Shelves | 7.25 | 3.2 | 12WB5C |
| 18 | 457 | 11.75 | 298 | 1 Shelf | 3 | 1.4 | 18WB1C |
| 18 | 457 | 21.63 | 548 | 1 to 3 Shelves | 6 | 2.7 | 18WB3C |
| 18 | 457 | 31.63 | 807 | 1 to 5 Shelves | 8.5 | 3.8 | 18WB5C |

For additional mounting brackets (single) order Cat. No. 9975C

Double mounting brackets are also available for use where continuous wall shelving is to be installed. **Cat. No. 9976C**

Load Rating: 200 lbs. (91kg) per shelf, not to exceed 200 lbs. (91kg) per unit.

Units must be secured to sufficient wall support structure.

Erecta Shelf® Wall Kit — {10.56}

Kit includes two shelves, shelf supports, and mounting brackets. Wall bolts and screws not included; they must be selected according to type of wall. Chrome.

| Shelf Length (in.) | Shelf Length (mm) | Overall Length (in.) | Overall Length (mm) | Shelf Width (in.) | Shelf Width (mm) | Overall Width (in.) | Overall Width (mm) | Overall Height (in.) | Overall Height (mm) | Approx. Pkd. Wt. (lbs.) | Approx. Pkd. Wt. (kg) | Cat. No. |
|--------------------|-------------------|----------------------|---------------------|-------------------|------------------|---------------------|--------------------|----------------------|---------------------|-------------------------|-----------------------|----------|
| 24 | 610 | 26.25 | 673 | 12 | 305 | 13 | 330 | 21 | 530 | 18.5 | 8.3 | 12WS12C |
| 36 | 914 | 38.25 | 971 | 12 | 305 | 13 | 330 | 21 | 530 | 25.25 | 11.3 | 12WS32C |
| 48 | 1219 | 50.25 | 1283 | 12 | 305 | 13 | 330 | 21 | 530 | 32 | 14.4 | 12WS52C |

Kit packaged in one box and UPS shippable.

Load Rating: 200 lbs. (91kg) per shelf, not to exceed 200 lbs. (91kg) per unit.

Units must be secured to sufficient wall support structure.

NSF Note: Wall shelving is NSF listed.



Wall Mount Brackets shown with MetroMax i Open Frame and Drop-In Basket.



Wall Mounts with Shelf (Shelf sold separately, see page 77)



12WS12C Erecta Shelf® Wall Kit

Metro Design Tools

The easy way to customize & specify in 3D.



Metro has created these amazing, proprietary tools to help you build, layout, and specify select Metro products. These tools are **FREE** to use and can be accessed on metro.com.

Give it a try... they are super-simple.

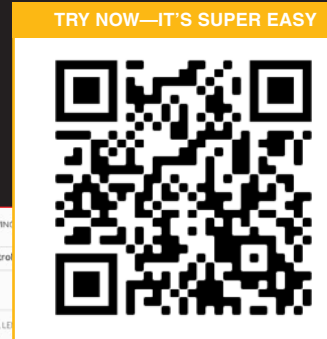
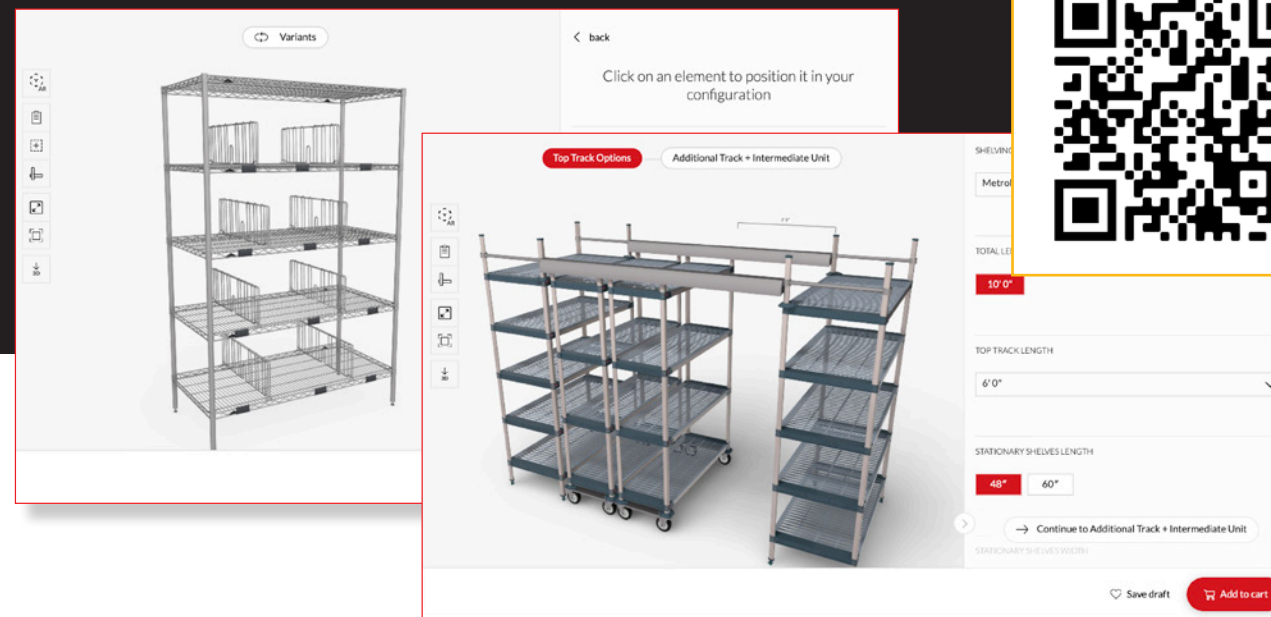

**Built to
get the job
done.**

METRO

SmartLever™
HD Super™

WORKSTATIONS & WORKTABLES

| | |
|---|----------------|
| Workstations & Worktables | 132-147 |
| SmartLever Workstations..... | 134-139 |
| Stainless Steel Worktables & Accessories..... | 140-145 |



LEARN MORE

Nothing gets in the way of productivity.



Ordering your SmartLever.

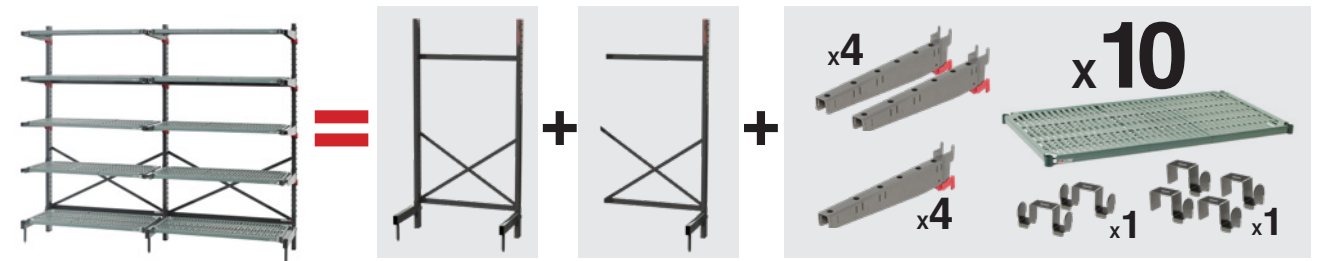

| Quantity Needed | Cat. No. | Description |
|-----------------|---------------------|-----------------------------------|
| 1 | SM762448-KIT | SmartLever 21x48 Starter Unit Kit |
| 1 | SM762448-ADD | SmartLever 21x48 Add-on Unit Kit |
| 4 | SMA24A | Pair 21" SmartLever Arms |

| Quantity Needed | Cat. No. | Description |
|-----------------|-------------------|------------------------------|
| 4 | SMA24A-ADD | Single 21" SmartLever Arms |
| 10 | PR2148NK3 | 21x48 Super Erecta Pro Shelf |
| 1 | LSH1 | Single Leg Hook (4 Pack) |
| 1 | LSH2 | Double Leg Hook (2 Pack) |

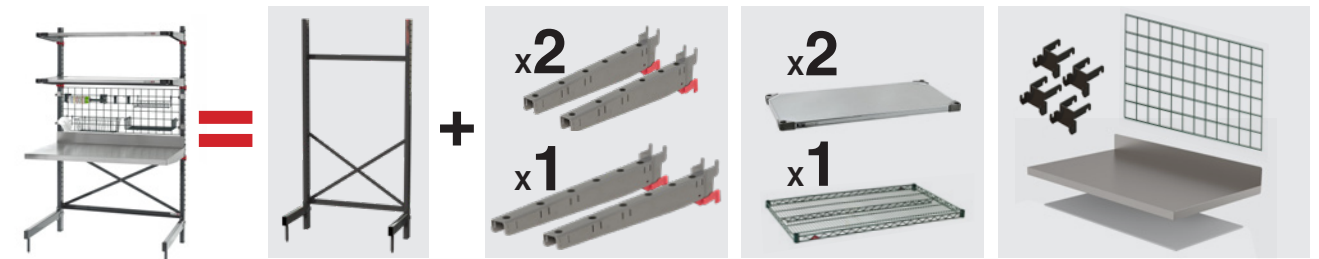

| Quantity Needed | Cat. No. | Description |
|-----------------|---------------------|-----------------------------------|
| 1 | SM763042-KIT | SmartLever 30x42 Starter Unit Kit |
| 1 | SMW42 | SmartLever 30x42 SS Work Surface |
| 1 | 3042NK3 | 30x42 Epoxy Coated Wire Shelf |
| 2 | SMA18A | Pair 18" SmartLever Arms |

| Quantity Needed | Cat. No. | Description |
|-----------------|-----------------|----------------------------------|
| 1 | SMA30A | Pair 30" SmartLever Arms |
| 1 | WG1842K3 | 18x42 SmartWall Accessory Grid |
| 1 | SMR | SmartLever Grid Bracket (4 pack) |
| 2 | 1842FS | 18x42 Flat Stainless Steel Shelf |

Note: Grid accessories are not included and can be ordered separately



SMARTLEVER ASSEMBLY



SmartLever™ Multifunctional Storage & Workstations — {17.30}

Create the ultimate usable space by combining shelving, stainless worksurface, and SmartWall productivity system.

Specifications

- Structure: Heavy gauge cold rolled steel electroplated and epoxy coated with stainless steel hardware.
- Work Surface: 16 gauge, type 304 stainless steel top with Duraplast anti-drumming support.
- Support Arms: 11-gauge stainless steel coated with epoxy.
- Dunnage: heavy gauge steel electroplated and epoxy coated
- Work surface and shelving height adjustable on 2" increments.
- Warranty: 10 year limited warranty against surface rust formation.
- Load Capacity:
 - The total weight load capacity of each model including the bottom shelf, is 2,800 lbs. (1271kg).
 - Each level (work surface or shelf) has a maximum evenly distributed weight load capacity of 600 lbs. (272kg).
 - The maximum uniformly distributed load on the Dunnage rack must not exceed 1,000 lbs. (454kg).

Safely Hold up to **2800 lbs.** per section.



Utilizes Metro Shelving including but not limited to: Super Erecta, Super Erecta Pro, SmartWall Grid and accessories, and Flat Stainless Shelves.



SmartLever Shelving U or L Configurations



SmartLever Shelving Workstation Integration



SmartLever Continuous Shelving



SmartLever Equipment Station



SmartLever's flexibility comes from its versatility. It's a modular system of Uprights, Legs, Cross Bracing, Arm, Shelves, Work Surfaces, and Accessories that gives you the ability to optimize storage and workspace throughout your facility.

Uprights & Legs

SmartLever's strength comes from its robust Upright and Leg System. Legs bolt to the upright and can be ordered separately or as part of our convenient Starter and Add-On Kits. Uprights allow Shelves to be adjusted and positioned on 2" increments.

| Part # | Description | Part # | Description |
|--------|------------------------|--------|----------------------------|
| SMU76 | 76" SmartLever Upright | SML18 | 18" Nominal SmartLever Leg |
| SMU86 | 86" SmartLever Upright | SML21 | 21" Nominal SmartLever Leg |
| | | SML24 | 24" Nominal SmartLever Leg |
| | | SML30 | 30" Nominal SmartLever Leg |

Cross Brace Kits

SmartLever's stability comes from its Cross Bracing System. Each Cross Brace Kit consists of two Cross Bars and a set of Cross Bracing.

| Part # | Description |
|--------|---|
| SMB24 | 24" Nominal SmartLever Cross Brace Kit w/Hardware |
| SMB30 | 30" Nominal SmartLever Cross Brace Kit w/Hardware |
| SMB36 | 36" Nominal SmartLever Cross Brace Kit w/Hardware |
| SMB42 | 42" Nominal SmartLever Cross Brace Kit w/Hardware |
| SMB48 | 48" Nominal SmartLever Cross Brace Kit w/Hardware |
| SMB54 | 54" Nominal SmartLever Cross Brace Kit w/Hardware |
| SMB60 | 60" Nominal SmartLever Cross Brace Kit w/Hardware |
| SMB72 | 72" Nominal SmartLever Cross Brace Kit w/Hardware |

Arms

SmartLever's **Patent Pending** Arm Design holds heavy loads, is more durable, can hold different width shelves on the same arm, and come with arm locks installed for the ultimate in adjustability and security. Sold as pairs or individually ("-ADD" parts) SmartLever Arms also come with Shelf Mounting Hooks and Locking Wedges

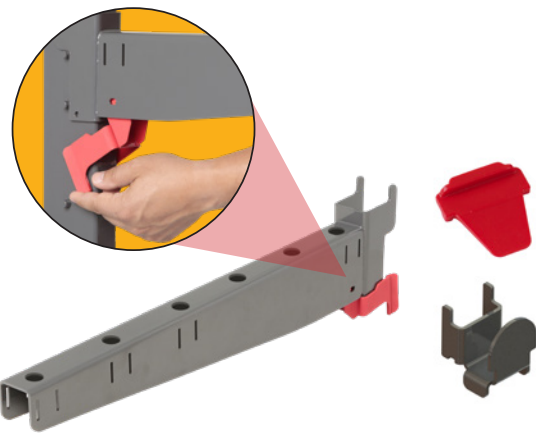

| Part # | Description | # of Arms | # of Shelf Mount Hooks | # of Locking Wedges |
|------------|---------------------------|-----------|------------------------|---------------------|
| SMA14A | Pair 14" SmartLever Arms | 2 | 4 | 4 |
| SMA14A-ADD | Single 14" SmartLever Arm | 1 | 4 | 4 |
| SMA18A | Pair 18" SmartLever Arms | 2 | 4 | 4 |
| SMA18A-ADD | Single 18" SmartLever Arm | 1 | 4 | 4 |
| SMA21A | Pair 21" SmartLever Arms | 2 | 4 | 4 |
| SMA21A-ADD | Single 21" SmartLever Arm | 1 | 4 | 4 |
| SMA24A | Pair 24" SmartLever Arms | 2 | 4 | 4 |
| SMA24A-ADD | Single 24" SmartLever Arm | 1 | 4 | 4 |
| SMA30A | Pair 30" SmartLever Arms | 2 | 4 | 4 |
| SMA30A-ADD | Single 30" SmartLever Arm | 1 | 4 | 4 |



Shelves

SmartLever's ultimate flexibility comes from the integration of standard Metro Shelving. All Super Erecta (round post) shelves work with SmartLever's shelf mounting hooks.

1. Select Super Erecta Pro shelving for all-around superior performance in all environments based on its easy-to-clean removable mat designs and inherent corrosion protection.
2. Choose Super Erecta for basic applications. Metroseal is recommended but all wire shelving finishes are compatible
3. Utilize Super Erecta Solid Shelving for hybrid work surfaces, work surface overhead shelves, or whenever spill mitigation is important. Stainless steel is recommended for use with SmartLever but all solid shelving styles are compatible
4. Super Erecta Dunnage hold heavy loads supported on SmartLever's Legs with the use of Single or Double Leg Hooks (also for use with other style shelves mounted on the Legs of the unit). Dunnage shelves hold 1,000 lbs. when mounted to Legs using Leg Hook (must order separately – see below) and 600 lbs. when mounted to Arms.

| Shelving Size L x W (in.) | Super Erecta Pro | Super Erecta Solid Stainless | Super Erecta Metroseal Green | Super Erecta Metroseal Gray | Super Erecta Brite | Super Erecta Chrome | Super Erecta Stainless | Super Erecta Metroseal Green |
|---------------------------|------------------|------------------------------|------------------------------|-----------------------------|--------------------|---------------------|------------------------|------------------------------|
| 14 24 | PR1424NK3 | 1424FS | 1424NK3 | 1424NK4 | 1424BR | 1424NC | 1424NS | - |
| 14 30 | PR1430NK3 | 1430FS | 1430NK3 | 1430NK4 | 1430BR | 1430NC | 1430NS | - |
| 14 36 | PR1436NK3 | 1436FS | 1436NK3 | 1436NK4 | 1436BR | 1436NC | 1436NS | - |
| 14 42 | PR1442NK3 | 1442FS | 1442NK3 | 1442NK4 | 1442BR | 1442NC | 1442NS | - |
| 14 48 | PR1448NK3 | 1448FS | 1448NK3 | 1448NK4 | 1448BR | 1448NC | 1448NS | - |
| 14 54 | - | - | - | - | - | - | - | - |
| 14 60 | PR1460NK3 | 1460FS | 1460NK3 | 1460NK4 | 1460BR | 1460NC | 1460NS | - |
| 14 72 | PR1472NK3 | - | 1472NK3 | 1472NK4 | 1472BR | 1472NC | 1472NS | - |
| 18 2 | PR1824NK3 | 1824FS | 1824NK3 | 1824NK4 | 1824BR | 1824NC | 1824NS | 1824DRK3 |
| 18 30 | PR1830NK3 | 1830FS | 1830NK3 | 1830NK4 | 1830BR | 1830NC | 1830NS | 1830DRK3 |
| 18 36 | PR1836NK3 | 1836FS | 1836NK3 | 1836NK4 | 1836BR | 1836NC | 1836NS | 1836DRK3 |
| 18 42 | PR1842NK3 | 1842FS | 1842NK3 | 1842NK4 | 1842BR | 1842NC | 1842NS | 1842DRK3 |
| 18 48 | PR1848NK3 | 1848FS | 1848NK3 | 1848NK4 | 1848BR | 1848NC | 1848NS | 1848DRK3 |
| 18 54 | PR1854NK3 | - | 1854NK3 | 1854NK4 | 1854BR | 1854NC | 1854NS | 1854DRK3 |
| 18 60 | PR1860NK3 | 1860FS | 1860NK3 | 1860NK4 | 1860BR | 1860NC | 1860NS | 1860DRK3 |
| 18 72 | PR1872NK3 | 1872FS | 1872NK3 | 1872NK4 | 1872BR | 1872NC | 1872NS | - |
| 21 24 | PR2124NK3 | 2124FS | 2124NK3 | 2124NK4 | 2124BR | 2124NC | 2124NS | 2124DRK3 |
| 21 30 | PR2130NK3 | 2130FS | 2130NK3 | 2130NK4 | 2130BR | 2130NC | 2130NS | 2130DRK3 |
| 21 36 | PR2136NK3 | 2136FS | 2136NK3 | 2136NK4 | 2136BR | 2136NC | 2136NS | 2136DRK3 |
| 21 42 | PR2142NK3 | 2142FS | 2142NK3 | 2142NK4 | 2142BR | 2142NC | 2142NS | 2142DRK3 |
| 21 48 | PR2148NK3 | 2148FS | 2148NK3 | 2148NK4 | 2148BR | 2148NC | 2148NS | 2148DRK3 |
| 21 54 | PR2154NK3 | - | 2154NK3 | 2154NK4 | 2154BR | 2154NC | 2154NS | 2154DRK3 |
| 21 60 | PR2160NK3 | 2160FS | 2160NK3 | 2160NK4 | 2160BR | 2160NC | 2160NS | 2160DRK3 |
| 21 72 | PR2172NK3 | - | 2172NK3 | 2172NK4 | 2172BR | 2172NC | 2172NS | - |
| 24 24 | PR2424NK3 | 2424FS | 2424NK3 | 2424NK4 | 2424BR | 2424NC | 2424NS | 2424DRK3 |
| 24 30 | PR2430NK3 | 2430FS | 2430NK3 | 2430NK4 | 2430BR | 2430NC | 2430NS | 2430DRK3 |
| 24 36 | PR2436NK3 | 2436FS | 2436NK3 | 2436NK4 | 2436BR | 2436NC | 2436NS | 2436DRK3 |
| 24 42 | PR2442NK3 | 2442FS | 2442NK3 | 2442NK4 | 2442BR | 2442NC | 2442NS | 2442DRK3 |
| 24 48 | PR2448NK3 | 2448FS | 2448NK3 | 2448NK4 | 2448BR | 2448NC | 2448NS | 2448DRK3 |
| 24 54 | PR2454NK3 | - | 2454NK3 | 2454NK4 | 2454BR | 2454NC | 2454NS | 2454DRK3 |
| 24 60 | PR2460NK3 | 2460FS | 2460NK3 | 2460NK4 | 2460BR | 2460NC | 2460NS | 2460DRK3 |
| 24 72 | PR2472NK3 | 2472FS | 2472NK3 | 2472NK4 | 2472BR | 2472NC | 2472NS | - |
| 30 36 | - | - | 3036NK3 | 3036NK4 | - | 3036NC | 3036NS | - |
| 30 42 | - | - | 3042NK3 | 3042NK4 | - | 3042NC | - | - |
| 30 48 | - | - | 3048NK3 | 3048NK4 | - | 3048NC | 3048NS | - |
| 30 54 | - | - | 3054NK3 | 3054NK4 | - | 3054NC | - | - |
| 30 60 | - | - | 3060NK3 | 3060NK4 | - | 3060NC | 3060NS | - |
| 30 72 | - | - | 3072NK3 | 3072NK4 | - | 3072NC | 3072NS | - |

*Arm size must match shelf depth. For example, 2148NK3 shelf will use SMA 21A.

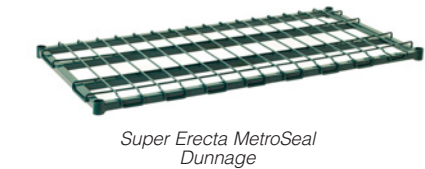
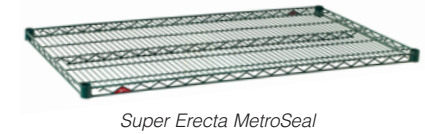
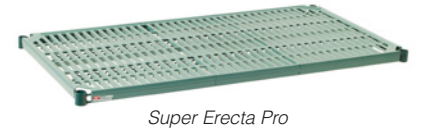

Leg Hooks

Leg hooks are used to install any shelf on the legs as the bottom shelf of the unit.



| Cat. No. | Description |
|----------|--------------------------|
| LSH1 | Single Leg Hook (4 Pack) |
| LSH2 | Double Leg Hook (2 Pack) |



Worktables.

What Type of Stainless Steel Do I Need?

The difference between 304 and 316 stainless steel is the chemical composition, with 316 containing a significant amount of molybdenum. The higher molybdenum content results in increased corrosion resistance. 316 stainless steel work surfaces are ideal for pharmaceutical manufacturing, medical, biomedical, life sciences and sterile applications where there is repeated use of harsh cleaning solutions or chloride solutions.



HD Super Heavy-Duty Worktables — {17.20}

- Seamless Type 304 or 316 stainless steel work surface and support structure with 1 5/8" posts.
- Shipped knocked down and can be assembled in minutes without tools.
- All HD Super worktables are 34" (864mm) high with stationary posts and leveling feet.
- All Mobile Worktables have special posts and four 5" (127mm) poly casters — 2 swivel/2 brake.



HD Super Heavy-Duty Worktables with Solid Bottom Shelf

| Length (in.) (mm) | Width (in.) (mm) | Description | 304 Stainless Steel | | 316 Stainless Steel | |
|-------------------|------------------|--------------------------|---------------------|----------------|---------------------|----------------|
| | | | Stationary Cat No. | Mobile Cat No. | Stationary Cat No. | Mobile Cat No. |
| 48 | 1219 | Worktable w/ Solid Shelf | WT305FS | MWT305FS | WT305FS-316 | MWT305FS-316 |
| 60 | 1524 | Worktable w/ Solid Shelf | WT306FS | MWT306FS | WT306FS-316 | MWT306FS-316 |
| 72 | 1825 | Worktable w/ Solid Shelf | WT307FS | MWT307FS | WT307FS-316 | MWT307FS-316 |
| 96 | 2439 | Worktable w/ Solid Shelf | WT309FS | MWT309FS | WT309FS-316 | MWT309FS-316 |
| 60 | 1524 | Worktable w/ Solid Shelf | WT366FS | MWT366FS | - | - |
| 72 | 1825 | Worktable w/ Solid Shelf | WT367FS | MWT367FS | - | - |
| 96 | 2439 | Worktable w/ Solid Shelf | WT369FS | MWT369FS | - | - |
| 60 | 1524 | Worktable w/ Solid Shelf | WT446FS | MWT446FS | - | - |
| 72 | 1825 | Worktable w/ Solid Shelf | WT447FS | MWT447FS | - | - |
| 96 | 2439 | Worktable w/ Solid Shelf | WT449FS | MWT449FS | - | - |

All 316 stainless steel top models use 316 stainless steel lower shelf and support components.

HD Super Heavy-Duty Worktables with 3-Sided Frame

| Length (in.) (mm) | Width (in.) (mm) | Description | 304 Stainless Steel | | 316 Stainless Steel | |
|-------------------|------------------|----------------------------|---------------------|----------------|---------------------|----------------|
| | | | Stationary Cat No. | Mobile Cat No. | Stationary Cat No. | Mobile Cat No. |
| 48 | 1219 | Worktable w/ 3-Sided Frame | WT305US | MWT305US | WT305US-316 | MWT305US-316 |
| 60 | 1524 | Worktable w/ 3-Sided Frame | WT306US | MWT306US | WT306US-316 | MWT306US-316 |
| 72 | 1825 | Worktable w/ 3-Sided Frame | WT307US | MWT307US | WT307US-316 | MWT307US-316 |
| 96 | 2439 | Worktable w/ 3-Sided Frame | WT309US | MWT309US | WT309US-316 | MWT309US-316 |
| 60 | 1524 | Worktable w/ 3-Sided Frame | WT366US | MWT366US | - | - |
| 72 | 1825 | Worktable w/ 3-Sided Frame | WT367US | MWT367US | - | - |
| 96 | 2439 | Worktable w/ 3-Sided Frame | WT369US | MWT369US | - | - |
| 60 | 1524 | Worktable w/ 3-Sided Frame | WT446US | MWT446US | - | - |
| 72 | 1825 | Worktable w/ 3-Sided Frame | WT447US | MWT447US | - | - |
| 96 | 2439 | Worktable w/ 3-Sided Frame | WT449US | MWT449US | - | - |

All 316 stainless steel top models use 316 stainless steel lower frame and support components.



HD Super Heavy-Duty Worktables with H-Frame

| Length (in.) (mm) | Width (in.) (mm) | Description | 304 Stainless Steel | | 316 Stainless Steel | |
|-------------------|------------------|----------------------|---------------------|----------------|---------------------|----------------|
| | | | Stationary Cat No. | Mobile Cat No. | Stationary Cat No. | Mobile Cat No. |
| 48 | 1219 | Worktable w/ H-Frame | WT305HS | MWT305HS | WT305HS-316 | MWT305HS-316 |
| 60 | 1524 | Worktable w/ H-Frame | WT306HS | MWT306HS | WT306HS-316 | MWT306HS-316 |
| 72 | 1825 | Worktable w/ H-Frame | WT307HS | MWT307HS | WT307HS-316 | MWT307HS-316 |
| 96 | 2439 | Worktable w/ H-Frame | WT309HS | MWT309HS | WT309HS-316 | MWT309HS-316 |
| 60 | 1524 | Worktable w/ H-Frame | WT366HS | MWT366HS | - | - |
| 72 | 1825 | Worktable w/ H-Frame | WT367HS | MWT367HS | - | - |
| 96 | 2439 | Worktable w/ H-Frame | WT369HS | MWT369HS | - | - |
| 60 | 1524 | Worktable w/ H-Frame | WT446HS | MWT446HS | - | - |
| 72 | 1825 | Worktable w/ H-Frame | WT447HS | MWT447HS | - | - |
| 96 | 2439 | Worktable w/ H-Frame | WT449HS | MWT449HS | - | - |

All 316 stainless steel top models use 316 stainless steel lower shelf and support components.



HD Super Heavy-Duty Worktables with Uprights — {17.26}

All Worktables with Overhead are 30" (760mm) wide and have rear posts that are approximately 88" (2235mm) high. Cantilever shelves for overhead models are sold separately.

| Length (in.) (mm) | Width (in.) (mm) | Description | 304 Stainless Steel | |
|-------------------|------------------|----------------------------|---------------------|----------------|
| | | | Stationary Cat No. | Mobile Cat No. |
| 60 | 1524 | Worktable w/ Solid Shelf | WTC306FS | - |
| 72 | 1825 | Worktable w/ Solid Shelf | WTC307FS | - |
| 96 | 2439 | Worktable w/ Solid Shelf | WTC309FS | - |
| 60 | 1524 | Worktable w/ 3-Sided Frame | WTC306US | - |
| 72 | 1825 | Worktable w/ 3-Sided Frame | WTC307US | - |
| 96 | 2439 | Worktable w/ 3-Sided Frame | WTC309US | - |

All 316 stainless steel top models use 316 stainless steel lower shelf and support components. 60" model uses 54" cantilevered shelves; all larger models use 60" cantilevered shelves.

Tables **DO NOT** include cantilevered upper shelves. Order separately below.



HD Super Cantilever Shelf — {10.67}

| Width/Length (in.) (mm) | Approx. Pkd. Wt. (lbs.) (kg) | Cat. No. Stainless |
|-------------------------|------------------------------|--------------------|
| 12x54 | 304x1372 | 1254CHS |
| 12x60 | 304x1524 | 1260CHS |



Standard-Duty Worktables— {17.40}

Space Saver Design 24" Wide (610mm)

Sturdy construction provides a robust 800 lb. load rating. Mobile tables are rated to 600 lbs. Type 304 Stainless Steel components. 1" (25mm) diameter posts and patented Super Erecta Shelf construction. Heavy-duty 14-gauge stainless steel virtually eliminates "drumming."

Preconfigured units are offered both in stationary with a leveling foot and mobile utilizing a 5" polymer corrosion resistant caster. Worktables can also be customized using Super Erecta® components in any finish to fit your application.



| Length (in.) (mm) | Width (in.) (mm) | Height (in.) (mm) | Description | 304 Stainless Steel | | | | |
|-------------------|------------------|-------------------|-------------|---------------------|----------------|----------------------------|-----------|------------|
| | | | | Stationary Cat No. | Mobile Cat No. | | | |
| 36 | 914 | 24 | 610 | 34 | 910 | Worktable w/ Solid Shelf | WTS2436FS | MWTS2436FS |
| 48 | 1219 | 24 | 610 | 34 | 910 | Worktable w/ Solid Shelf | WTS2448FS | MWTS2448FS |
| 60 | 1524 | 24 | 610 | 34 | 910 | Worktable w/ Solid Shelf | WTS2460FS | MWTS2460FS |
| 36 | 914 | 24 | 610 | 34 | 910 | Worktable w/ 3-Sided Frame | WTS2436US | MWTS2436US |
| 48 | 1219 | 24 | 610 | 34 | 910 | Worktable w/ 3-Sided Frame | WTS2448US | MWTS2448US |
| 60 | 1524 | 24 | 610 | 34 | 910 | Worktable w/ 3-Sided Frame | WTS2460US | MWTS2460US |

All Models use 316 stainless steel lower shelf and support components.



Stainless Steel & Resin Top Worktables

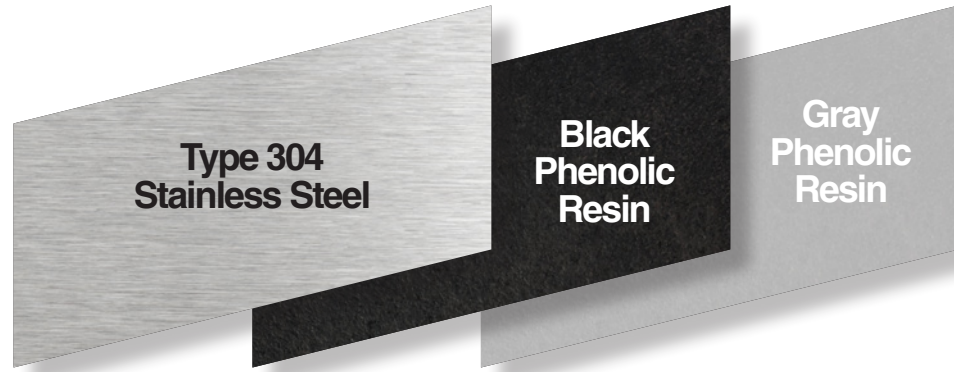

Countertop Materials

Stainless Steel: Worksurfaces are fabricated from Type 304 stainless steel which provides excellent protection in corrosive environments.

Phenolic resin: Compression molded of organic fiber-reinforced phenolic core with an integrally cured thermoset resin surface.

What material do I need?

| Characteristics | Phenolic Resin | Stainless Steel |
|---------------------|----------------|-----------------|
| Heat Resistance | Fair* | Excellent |
| Abrasion Resistance | Excellent | Good |
| Impact Resistance | Excellent | Good |
| Strength | Excellent | Good |
| Stain Resistance | Good | Good |

* Discolors with High Heat.

Choose the right casters for your application to make it mobile.

Mobile-Ready Worktables DO NOT include casters.
Casters must be ordered separately.



Recommended Casters For Stainless Steel Mobile Worktables
(Four brake casters are recommended for maximum table stability)

Caster Selection Guide

| Caster Series | Wheel Material | Rollability | Floor Protection | Noise | Load Rating (lbs.) (kg) | Corrosion Resistance | Cart Washable | Antimicrobial Additive in Wheel |
|-----------------------|---------------------|-------------|------------------|----------|-------------------------|----------------------|---------------|---------------------------------|
| 5MDA/5MDBA (brake) | High Modulus Rubber | Good | Good | Low | 250 114 | Low | No | No |
| 5MP/5MPB (brake) | Polyurethane | Good | Good | Moderate | 300 137 | Low | No | No |
| 5PC/5PCB (brake) | Polyurethane | Good | Good | Moderate | 300 137 | Medium | No | No |
| 5PCM/5PCBM (brake) | Polyurethane | Good | Good | Moderate | 300 137 | Medium | No | Yes |
| 5MPGSA/5MPBGS (brake) | Polyurethane | Good | Good | Moderate | 300 137 | High | Yes | No |

NOTE: The total weight of the equipment and its load should not exceed three times the load rating per caster. Additional stem casters, in various sizes and wheel materials, are available.



Stainless Steel & Phenolic Resin Top Worktables — {52.03}

- Corrosion-proof stainless steel construction throughout.
- Easy to clean smooth surfaces. Mobile units can be easily moved for cleaning.
- Available top materials include Type 304 stainless and TRESPA Phenolic resin (black or gray).
- Casters and accessories are available, but must be ordered separately.
- All tops are 30" (755mm) Wide.

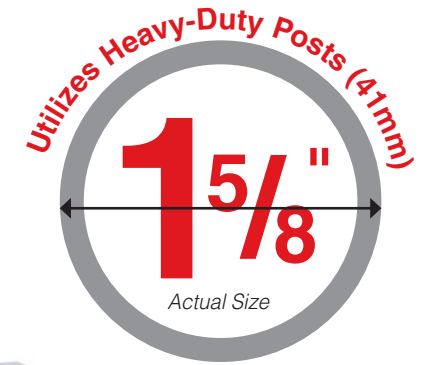

Island-Top

Stainless Steel Worktables

| Length (in.) (mm) | Width (in.) (mm) | Description | Stationary Cat No. | Mobile-Ready Cat No. |
|-------------------|------------------|----------------------------|--------------------|----------------------|
| 30 755 | 30 755 | Worktable w/ Solid Shelf | LTS30IS | LTSM30IS |
| 36 914 | 30 755 | Worktable w/ Solid Shelf | LTS36IS | LTSM36IS |
| 48 1219 | 30 755 | Worktable w/ Solid Shelf | LTS48IS | LTSM48IS |
| 60 1524 | 30 755 | Worktable w/ Solid Shelf | LTS60IS | LTSM60IS |
| 30 755 | 30 755 | Worktable w/ 3-Sided Frame | LTS30UIS | LTSM30UIS |
| 36 914 | 30 755 | Worktable w/ 3-Sided Frame | LTS36UIS | LTSM36UIS |
| 48 1219 | 30 755 | Worktable w/ 3-Sided Frame | LTS48UIS | LTSM48UIS |
| 60 1524 | 30 755 | Worktable w/ 3-Sided Frame | LTS60UIS | LTSM60UIS |



Mobile-Ready Worktables DO NOT include casters.
Casters must be ordered separately.

LTSM30IS with casters (ordered separately)

Backsplash

Stainless Steel Worktables

| Length (in.) (mm) | Width (in.) (mm) | Description | Stationary Cat No. | Mobile-Ready Cat No. |
|-------------------|------------------|----------------------------|--------------------|----------------------|
| 30 755 | 30 755 | Worktable w/ Solid Shelf | LTS30S | LTSM30S |
| 36 914 | 30 755 | Worktable w/ Solid Shelf | LTS36S | LTSM36S |
| 48 1219 | 30 755 | Worktable w/ Solid Shelf | LTS48S | LTSM48S |
| 60 1524 | 30 755 | Worktable w/ Solid Shelf | LTS60S | LTSM60S |
| 30 755 | 30 755 | Worktable w/ 3-Sided Frame | LTS30US | LTSM30US |
| 36 914 | 30 755 | Worktable w/ 3-Sided Frame | LTS36US | LTSM36US |
| 48 1219 | 30 755 | Worktable w/ 3-Sided Frame | LTS48US | LTSM48US |
| 60 1524 | 30 755 | Worktable w/ 3-Sided Frame | LTS60US | LTSM60US |



Mobile-Ready Worktables DO NOT include casters.
Casters must be ordered separately.

LTSM30US with optional accessory wire shelf

Black

Phenolic Top Worktables

| Length (in.) (mm) | Width (in.) (mm) | Description | Stationary Cat No. | Mobile-Ready Cat No. |
|-------------------|------------------|----------------------------|--------------------|----------------------|
| 30 755 | 30 755 | Worktable w/ Solid Shelf | LTS30PB | LTSM30PB |
| 36 914 | 30 755 | Worktable w/ Solid Shelf | LTS36PB | LTSM36PB |
| 48 1219 | 30 755 | Worktable w/ Solid Shelf | LTS48PB | LTSM48PB |
| 60 1524 | 30 755 | Worktable w/ Solid Shelf | LTS60PB | LTSM60PB |
| 30 755 | 30 755 | Worktable w/ 3-Sided Frame | LTS30UPB | LTSM30UPB |
| 36 914 | 30 755 | Worktable w/ 3-Sided Frame | LTS36UPB | LTSM36UPB |
| 48 1219 | 30 755 | Worktable w/ 3-Sided Frame | LTS48UPB | LTSM48UPB |
| 60 1524 | 30 755 | Worktable w/ 3-Sided Frame | LTS60UPB | LTSM60UPB |



Mobile-Ready Worktables DO NOT include casters.
Casters must be ordered separately.

LTSM30PB with casters (ordered separately)

Gray

Phenolic Top Worktables

| Length (in.) (mm) | Width (in.) (mm) | Description | Stationary Cat No. | Mobile-Ready Cat No. |
|-------------------|------------------|----------------------------|--------------------|----------------------|
| 30 755 | 30 755 | Worktable w/ Solid Shelf | LTS30PG | LTSM30PG |
| 36 914 | 30 755 | Worktable w/ Solid Shelf | LTS36PG | LTSM36PG |
| 48 1219 | 30 755 | Worktable w/ Solid Shelf | LTS48PG | LTSM48PG |
| 60 1524 | 30 755 | Worktable w/ Solid Shelf | LTS60PG | LTSM60PG |
| 30 755 | 30 755 | Worktable w/ 3-Sided Frame | LTS30UPG | LTSM30UPG |
| 36 914 | 30 755 | Worktable w/ 3-Sided Frame | LTS36UPG | LTSM36UPG |
| 48 1219 | 30 755 | Worktable w/ 3-Sided Frame | LTS48UPG | LTSM48UPG |
| 60 1524 | 30 755 | Worktable w/ 3-Sided Frame | LTS60UPG | LTSM60UPG |



Worktables DO NOT include casters.
Casters must be ordered separately.

LTSM30PG0 with casters (ordered separately)

Leveling feet on stationary units have 1.250 (31mm) vertical adjustment.
*Casters ordered separately. Refer to Caster Selection Guide for more information.
Stainless Tables are load rated at 50 lbs. per sq. foot (0.24kg per sq. cm) up to a maximum of 600 lbs. (273kg) assuming evenly distributed load and caster specification meets requirement.
Note: Mobile posts include an adaptor insert that will accept Metro 5" (127mm) stem casters.



Stainless Steel & Resin Top Worktable Accessories

Stainless Worktable Accessories — {52.03}

Backsplash

4" (102mm) high. Attaches to phenolic table top using pre-drilled holes. Match length and color with selected countertop.

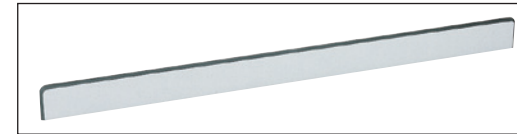

LT30BSG



LT30WS

| Length (in.) (mm) | Approx. Pkd. Wt. (lbs.) (kg) | Cat. No. Black | Cat. No. Gray |
|-------------------------------------|------------------------------|----------------|---------------|
| 27 ³ / ₄ 705 | 5.5 2.5 | LT30BSB | LT30BSG |
| 33 ³ / ₄ 875 | 6.5 2.9 | LT36BSB | LT36BSG |
| 45 ³ / ₄ 1162 | 7.5 3.4 | LT48BSB | LT48BSG |
| 57 ³ / ₄ 1466 | 9.5 4.3 | LT60BSB | LT60BSG |

Wire Shelf

Stainless shelves available.

| Length (in.) (mm) | Approx. Pkd. Wt. (lbs.) (kg) | Cat. No. Stainless |
|-------------------------------------|------------------------------|--------------------|
| 22 ³ / ₈ 568 | 6 2.7 | LT30WS |
| 28 ³ / ₈ 720 | 7.5 3.4 | LT36WS |
| 40 ³ / ₈ 1025 | 10 4.5 | LT48WS |
| 52 ³ / ₈ 1330 | 12 5.4 | LT60WS |

Note: Shelves are load rated for a maximum of 150 lbs. (68kg).



Stainless Keyboard Tray

Fits 48" and 60" (1219 and 1524mm) table lengths. Stainless keyboard tray and stainless drawer will both fit 60" (1524mm) long table.

Cat. No. LTSKB



Stainless Drawer for Phenolic Resin tops

Fits 30", 36", 48" and 60" (760, 914, 1219 and 1524mm) table lengths. Drawer, when fully extended, provides a 7.625" (194mm) opening. Stainless keyboard tray and stainless drawer will both fit 60" (1524mm) long table.

Cat. No. LTSD6



Surface Mount Swing Arm for Flat Monitor

Cat. No. LTFMA

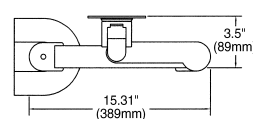
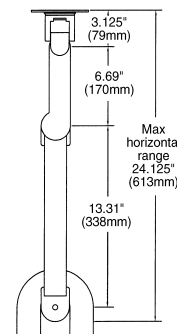
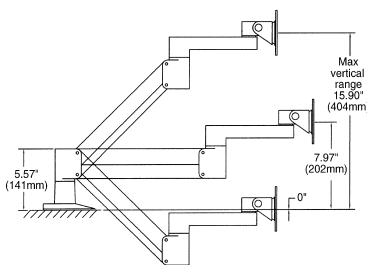

HD Super Heavy-Duty Worktable Accessories

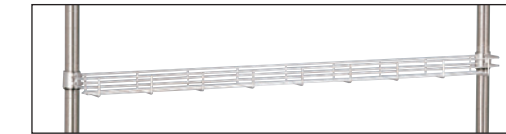

Utility Rack



Utility Hook



Deluxe Drawer

HD Super™ Accessories for Worktables with Overhead — {17.26}

Utility Racks for Overhead Models

Inside dimensions measure 1.94" (48mm) high and 4.36" (109mm) wide.

| Inside Length (in.) (mm) | Fits Units (in.) | Finish | Approx. Pkd. Wt. (lbs.) (kg) | Cat. No. |
|--------------------------|-------------------|---------------|------------------------------|----------|
| 51.56 1406 | 60 long | Chrome-Plated | 7.7 3.5 | 654SRC |
| 57.56 1406 | 72 long & 96 long | Chrome-Plated | 8.3 3.8 | 660SRC |

Utility Hook for Cantilever Shelves

| Width/Height/Depth (in.) (mm) | Finish | Approx. Pkd. Wt. (lbs.) (kg) | Cat. No. |
|-------------------------------|-----------|------------------------------|----------|
| .36x3.44x1.7 9x87x43 | Chrome | 0.1 .045 | HK23C |
| .36x3.44x1.7 9x87x43 | Stainless | 0.1 .045 | HK23S |

Accessories for All Worktables

Economy Drawer

| Overall Dimensions Width/Length/Height (in.) (mm) | Dimensions Inside Bottom (in.) (mm) | Approx. Pkd. Wt. (lbs.) (kg) | Cat. No. |
|---|-------------------------------------|------------------------------|----------|
| 14.25x28x5.75 362x711x146 | 10x16 254x406 | 6.8 3.1 | WTD21C |

Deluxe Drawer

Table accepts up to two drawers stacked.

| Overall Dimensions Width/Length/Height (in.) (mm) | Dimensions Inside Bottom (in.) (mm) | Approx. Pkd. Wt. (lbs.) (kg) | Cat. No. |
|---|-------------------------------------|------------------------------|----------|
| 24x25.75x7.5 610x654x191 | 20x20 508x508 | 31 13.9 | WTD51S |

HD Super Replacement Parts

HD Super™ Replacement Parts



Foot Plates 3.5" (89mm)
Cat. No. 9993HS



HD Super Plastic Split Sleeves
4 pair per bag
Cat. No. 9985H



Donut Bumpers 5.5" (140mm)
Fit 1.625" (41mm) posts only.
Cat. No. 9992H



HD Super Aluminum Split Sleeves with Zinc Ring
4 pair per bag
Cat. No. 9986HZ

Wall Mounting Brackets (not shown)
Cat. No. 9984HZ



**Move,
store &
secure
what
matters
most.**

myCart®
Deep Ledge

UTILITY CARTS & DUNNAGE

| | |
|-------------------------------------|----------------|
| Utility Carts, Dunnage | 146-157 |
| Polymer Utility Carts..... | 148-151 |
| Wire & Solid Utility Carts..... | 152-153 |
| Dunnage Racks & Shelves..... | 154-155 |



It's myCart, get your own.



Better Containment!

Ship's edge retains small spills and prevents items from sliding off during transport.



Make it yours.



Easy & Useful

Easy-grip handle and roomy utility tray



myCart

Utility Cart

Easy to clean surface



Corrosion proof & impact resistant polymer shelves.

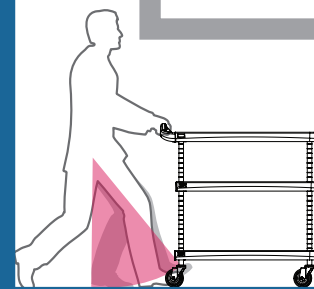

50% more legroom

You won't hit your shins or kick the cart!

Cleanable

- NSF Listed.
- Smooth surfaces easily wipe clean and won't stain.
- Specific models available with Microban® Antimicrobial product protection.

Durable

- Corrosion proof, impact resistant shelves are designed to withstand daily abuse.
- Sturdy construction: 300 lb. (136kg), 400 lb. (181kg), and 500 lb. (227kg) capacity models available.

User Friendly

- Additional legroom puts more distance between the shelves and you. You can push the cart more freely without hitting your shins and feet off the cart.
- Right-sized for common containers and racks.
- Large covered utility tray organizes small items and easily wipes clean.
- Easy-grip handle and four swivel casters ensure easy maneuvering.
- Each cart comes with two personalization labels for easy



myCart Series® — {12.29}

- Available in 2-shelf and 3-shelf configurations.
- .44" (11mm) deep ship's edge lip around shelf perimeter.
- MY1627 and MY2030 Base Model specs: Chrome posts, 4" (102mm) non-marking swivel casters. 150 lbs. (68kg) capacity per shelf.
- MY2636 Base Model specs: Chrome posts, 5" (127mm) swivel resilient rubber casters, 200 lbs. (90kg) capacity per shelf.



Carts

| Width/Length/Height (in.) | | Width/Length/Height (mm) | | Description | Load Rating Per Cart (lbs.) (kg) | | Approx. Pkd. Wt. (lbs.) (kg) | | Cat. No. Gray | Cat. No. Black | Cat. No. Blue with Antimicrobial | Cat. No. Purple |
|---------------------------|--------|--------------------------|-------|--------------------|----------------------------------|-----|------------------------------|------|---------------|----------------|----------------------------------|-----------------|
| 18.31 | 2x31.5 | 465 | x800 | 2-shelf base model | 300 | 136 | 28.5 | 12.9 | MY1627-24G | MY1627-24BL | MY1627-24BU | — |
| 18.31 | 2x31.5 | 465 | x800 | 3-shelf base model | 400 | 181 | 34 | 15.4 | MY1627-34G | MY1627-34BL | MY1627-34BU | — |
| 23.88 | x34.38 | 595 | x873 | 2-shelf base model | 300 | 136 | 33 | 15 | MY2030-24G | MY2030-24BL | MY2030-24BU | MY2030-24AP |
| 23.88 | x34.38 | 595 | x873 | 3-shelf base model | 400 | 181 | 41.5 | 19 | MY2030-34G | MY2030-34BL | MY2030-34BU | MY2030-34AP |
| 27.69 | x40.25 | 703 | x1022 | 2-shelf base model | 400 | 181 | 40 | 18.1 | MY2636-25G | MY2636-25BL | MY2636-25BU | — |
| 27.69 | x40.25 | 703 | x1022 | 3-shelf base model | 500 | 227 | 51 | 23.1 | MY2636-35G | MY2636-35BL | MY2636-35BU | — |

Accessories

- Utility bin and wastebasket can be easily removed from their holders to empty contents or for routine cleaning.

| Width/Height/Depth (in.) | | Width/Height/Depth (mm) | | Description | Fits Cart | Load Rating (lbs.) (kg) | | Approx. Pkd. Wt (lbs.) (kg) | | Cat. No. | | |
|--------------------------|--------|-------------------------|-----|-------------|-----------|-------------------------|--------|-----------------------------|------|----------|-----|-------|
| 17.88 | x16.25 | x14.75 | 454 | x413 | x375 | Wastebasket + Holder | MY1627 | 25 | 11.3 | 5.7 | 2.5 | MYWB1 |
| 23 | x16.25 | x14.75 | 584 | x413 | x375 | Wastebasket + Holder | MY2030 | 25 | 11.3 | 5.8 | 2.6 | MYWB2 |
| 14.38 | x15.38 | x10.38 | 365 | x391 | x264 | Wastebasket Only | | | | 2.8 | 1.3 | MF222 |
| 17.38 | x7 | x15.25 | 454 | x178 | x387 | Utility Bin + Holder | MY1627 | 25 | 11.3 | 5 | 2.2 | MYUB1 |
| 23 | x7 | x15.25 | 584 | x178 | x387 | Utility Bin + Holder | MY2030 | 25 | 11.3 | 5.1 | 2.3 | MYUB2 |
| 16.38 | x6 | x11 | 416 | x152 | x279 | Utility Bin Only | | | | 2 | 0.9 | UB1 |



Wastebasket and Holder

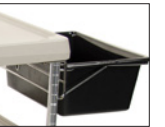

Utility Bin and Holder

Personalization Labels

- Personalization labels provide easy identification
- Constructed of polyester material with a clear polyester flap to protect written information from wiping off.

4.37"L x .875"H (117.5x22.4mm)
Cat. No. MYCARTLBL-10PK (Pack of 10)



MY1627

Easy-grip handle and utility tray

- Small footprint for tight spaces.
- Accommodates Metro tote boxes and ISO totes.



MY2030

MY2030 cart handle has built-in recessed support channel to manage odd shaped items.

- Right-sized to fit: Glass & dish racks, bussing totes, silverware bins, milk crates.



MY2636

MY2636 cart handle has a built-in slot to hold scanners and labelers.

- Ideal for large bulky items. 5" (127mm) Caster makes cart easier to maneuver. 3-shelf model holds up to 500 lbs.

Replacement Casters

4" (102mm) non-marking swivel caster. Used with MY1627 and MY2030 models.
Cat. No. RPBC4M-4 (Bag of 4)

5" (127mm) swivel resilient rubber caster. Used with MY2636 models.
Cat. No. 5M (sold individually)

Indicates antimicrobial product.



What is Microban Antimicrobial Technology?

An antimicrobial is an additive placed into a product during the manufacturing process. By placing this additive, the product receives protection from microorganisms like bacteria, mold, mildew, and fungi. These organisms are known to cause odor and stains if not appropriately inhibited. By pairing your product with Microban Antimicrobial Technology, you reduce damaging bacteria and improve the lifespan of your product.

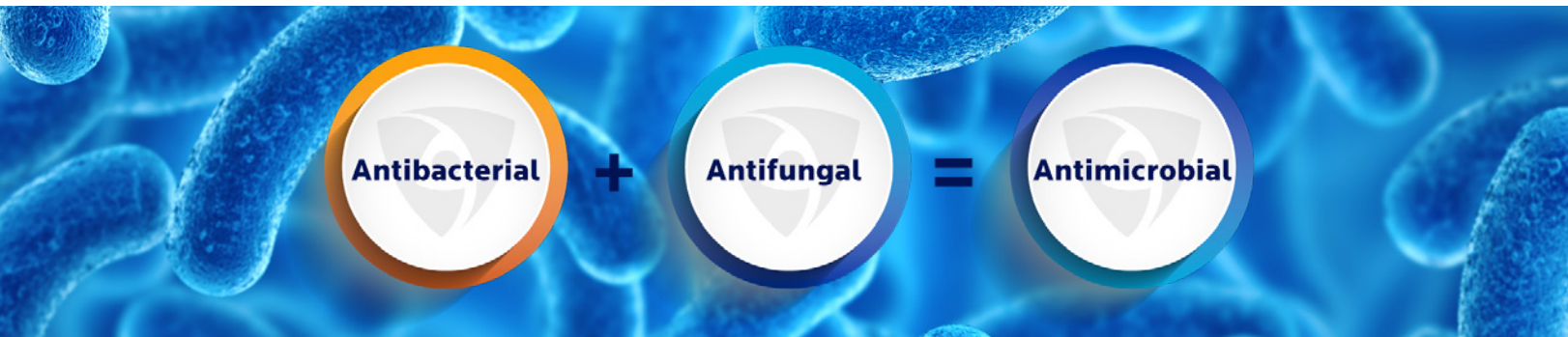

Microban Antimicrobial Protection works 24/7 to create an unlivable environment for microbes while helping to improve the appearance of the product by preventing stains and odor caused by bacterial build up. On an unprotected surface, bacteria can double in number every 20 minutes, leading to a full infestation in no-time, but with Microban antimicrobial technology, you can rest assured that your product remains cleaner between cleanings.

What are the benefits of a product with Microban antimicrobial protection?

- Helps prevent the growth of bacteria, fungi, mold, and mildew
- Keeps surfaces visibly cleaner
- Keeps products "cleaner between cleanings."
- Makes cleaning products easier
- Keeps surfaces cleaner longer after cleaning
- Will never wear down, as it is incorporated into the materials of the product
- Lasts the life of the product

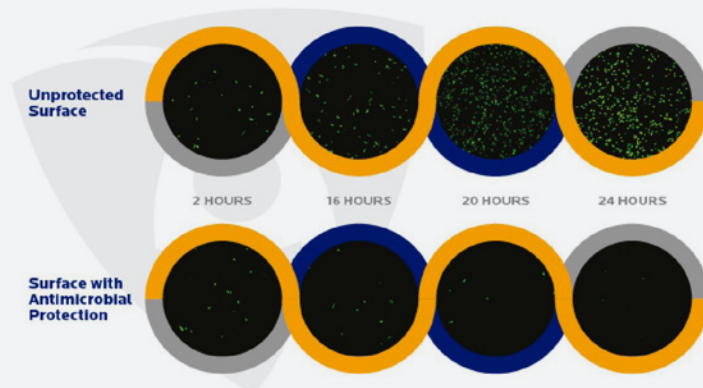

UTILITY CARTS



Deep Ledge Utility Carts —{12.28}

Specially designed with a 2.75" (70mm) deep ledge to contain product and spills.

- Polymer shelves are easy to clean and corrosion proof.
- Available colors are gray, black, and blue. Blue contains Microban antimicrobial product protection.
- Available in 2-shelf and 3-shelf models.
- Center shelf option adjusts at 1" (25mm) increments.

| Width/Length/Height (in.) | Width/Length/Height (mm) | Description | Approx. Pkd. Wt. (lbs.) (kg) | | Cat. No.* | Cat. No. Slate Blue with Microban |
|---------------------------|--------------------------|--------------|------------------------------|------|-----------|-----------------------------------|
| 21.5x33.75x33.25 | 546x857x845 | 2-shelf unit | 29 | 31.1 | BC2030-2D | BC2030-2DMB |
| 21.5x33.75x33.25 | 546x857x845 | 3-shelf unit | 37.5 | 17.0 | BC2030-3D | BC2030-3DMB |
| 27x39.5x33.25 | 685x1003x845 | 2-shelf unit | 35 | 15.9 | BC2636-2D | BC2636-2DMB |
| 27x39.5x33.25 | 685x1003x845 | 3-shelf unit | 46.5 | 21.1 | BC2636-3D | BC2636-3DMB |

*Add color designation to part number when ordering: Gray (G), Black (BL). Example: BC2030-3DG = 3-shelf gray cart.

Weight load capacity for Deep Ledge series.
150 lbs. (68kg) per shelf.
2-shelf model: 300 lbs. (136kg)
3-shelf model: 400 lbs. (181kg)



Accessories and Replacement Casters — {12.28}

- Utility Bin and Wastebasket can be easily removed from the holders to empty contents or for routine cleaning.

| Description | Fits Cart | Width/Height/Depth (in.) | Width/Height/Depth (mm) | Approx. Pkd. Wt. (lbs.) (kg) | | Deep Ledge Cat. No. |
|----------------------|-----------|--------------------------|-------------------------|------------------------------|-----|---------------------|
| Wastebasket + Holder | BC2030 | 21.25x27.5x13.25 | 540x700x337 | 8.0 | 3.8 | BCWB2D |
| Utility Bin + Holder | BC2030 | 21.25x7.75x14.5 | 540x197x368 | 6.0 | 2.7 | BCUB2D |
| Wastebasket Only | | 14.38x15.38x10.38 | 365x391x264 | 2.8 | 1.3 | MF222 |
| Utility Bin Only | | 16.38x6x11 | 416x152x279 | 2.0 | 0.9 | UB1 |
| Replacement Caster | | | | | | 4MA |

Note: Caster kit contains four 4" (102mm) swivel casters.



Basket Cart

Includes two light-duty basket style shelves, one standard wire shelf, four posts, extended handle, and four 4" diameter swivel casters (two with brakes)

- Basket shelves have a 3.5" (89mm) high edge to secure contents during transport.
- Durable chrome finish
- 400 lbs. (182kg) capacity per cart; 150 lbs. (68kg) capacity per shelf
- Ships in one box



| Shelf Width/Length (in.) | Shelf Width/Length (mm) | Overall Length (including handle) (in.) | Overall Length (including handle) (mm) | Overall Height (in.) | Overall Height (mm) | Approx. Pkd. Wt. (lbs.) (kg) | Cat. No. |
|--------------------------|-------------------------|---|--|----------------------|---------------------|------------------------------|------------|
| 18x36 | 457x914 | 39.88 | 1013 | 40.13 | 1020 | 49 22 | BASCART-SR |



Cart comes in point-of-sale box

UTILITY CARTS



MW200 Series



MW400 Series



MW600 Series



MW700 Series

MW Series Utility Carts — {12.01}{12.05} NSF

- Consist of Super Erecta wire shelves with plastic split sleeves, two one-piece handles of matching finish, and designated casters with donut bumpers.
- Two- and three-tier models available.
- 375 lbs. (170kg) weight capacity per cart. MW carts use light-duty resilient casters.
- 18" (457mm) wide carts have 4" (102mm) casters. Cart is 38" (965mm) high.
- 21" and 24" (530 and 610mm) wide carts have 5" (127mm) casters. Cart is 39" (990mm) high.

Utility Carts with Stainless Steel Solid Shelves

| Width/Length (in.) | Width/Length (mm) | Approx. Pkd. Wt. (lbs.) | Approx. Pkd. Wt. (kg) | Cat. No. 2-Shelf | Approx. Pkd. Wt. (lbs.) | Approx. Pkd. Wt. (kg) | Cat. No. 3-Shelf |
|--------------------|-------------------|-------------------------|-----------------------|------------------|-------------------------|-----------------------|------------------|
| 18x24 | 457x610 | 40 | 18.1 | MW103 | 48 | 21.8 | MW203 |
| 18x30 | 457x760 | 45 | 20.4 | MW104 | 53 | 24.0 | MW204 |
| 18x36 | 457x914 | 48 | 21.8 | MW105 | 59 | 26.8 | MW205 |
| 21x36 | 530x914 | 54 | 24.5 | MW106 | 74 | 33.6 | MW206 |
| 24x36 | 610x914 | 60 | 27.2 | MW108 | 66 | 29.9 | MW208 |

Utility Carts with 1 Solid, 2 Wire Shelves

| Width/Length (in.) | Width/Length (mm) | Approx. Pkd. Wt. (lbs.) | Approx. Pkd. Wt. (kg) | Shelf Material | Handles | Cat. No. |
|--------------------|-------------------|-------------------------|-----------------------|-------------------------|---------|----------|
| 18x24 | 457x610 | 43 | 19.5 | Stainless Steel, Chrome | Chrome | MW401 |
| 18x30 | 457x760 | 47 | 21.3 | Stainless Steel, Chrome | Chrome | MW402 |
| 18x36 | 457x914 | 52 | 23.6 | Stainless Steel, Chrome | Chrome | MW403 |
| 21x36 | 530x914 | 59 | 26.8 | Stainless Steel, Chrome | Chrome | MW404 |
| 24x36 | 610x914 | 65 | 29.5 | Stainless Steel, Chrome | Chrome | MW406 |

Utility Carts with 2 Wire Shelves

| Width/Length (in.) | Width/Length (mm) | Approx. Pkd. Wt. (lbs.) | Approx. Pkd. Wt. (kg) | Shelf Material | Handles | Cat. No. |
|--------------------|-------------------|-------------------------|-----------------------|-----------------|-----------------|----------|
| 18x24 | 457x610 | 34 | 15.4 | Chrome | Chrome | MW601 |
| 18x24 | 457x610 | 34 | 15.4 | Stainless Steel | Stainless Steel | MW602 |
| 18x30 | 457x760 | 37 | 16.8 | Chrome | Chrome | MW603 |
| 18x30 | 457x760 | 37 | 16.8 | Stainless Steel | Stainless Steel | MW604 |
| 18x36 | 457x914 | 40 | 18.1 | Chrome | Chrome | MW605 |
| 18x36 | 457x914 | 39 | 17.7 | Stainless Steel | Stainless Steel | MW606 |
| 21x36 | 530x914 | 44 | 20.0 | Chrome | Chrome | MW607 |
| 21x36 | 530x914 | 44 | 20.0 | Stainless Steel | Stainless Steel | MW608 |
| 24x36 | 610x914 | 47 | 21.3 | Chrome | Chrome | MW611 |
| 24x36 | 610x914 | 46 | 20.9 | Stainless Steel | Stainless Steel | MW612 |

Utility Carts with 3 Wire Shelves

| Width/Length (in.) | Width/Length (mm) | Approx. Pkd. Wt. (lbs.) | Approx. Pkd. Wt. (kg) | Shelf Material | Handles | Cat. No. |
|--------------------|-------------------|-------------------------|-----------------------|-----------------|-----------------|----------|
| 18x24 | 457x610 | 39 | 17.6 | Chrome | Chrome | MW701 |
| 18x24 | 457x610 | 38 | 17.2 | Stainless Steel | Stainless Steel | MW702 |
| 18x30 | 457x760 | 43 | 19.5 | Chrome | Chrome | MW703 |
| 18x30 | 457x760 | 42 | 19.1 | Stainless Steel | Stainless Steel | MW704 |
| 18x36 | 457x914 | 47 | 21.3 | Chrome | Chrome | MW705 |
| 18x36 | 457x914 | 45 | 20.4 | Stainless Steel | Stainless Steel | MW706 |
| 21x36 | 530x914 | 50 | 22.7 | Chrome | Chrome | MW707 |
| 21x36 | 530x914 | 50 | 22.7 | Stainless Steel | Stainless Steel | MW708 |
| 24x36 | 610x914 | 60 | 27.7 | Chrome | Chrome | MW711 |
| 24x36 | 610x914 | 57 | 25.9 | Stainless Steel | Stainless Steel | MW712 |



HEAVY-DUTY UTILITY CARTS

SP Series Utility Carts — {12.10} NSF

- Consist of Super Erecta wire shelves with plastic split sleeves, two one-piece handles of matching finish, and designated casters with donut bumpers.
- Two- and three-tier models available.
- 5" (127mm) casters allow for transport of heavier loads than the MW Series Carts.
- 39" (990mm) high.

Super Erecta Brite finish — 600 lbs. (273kg) capacity per cart

- 5M Resilient Rubber Casters; casters have plated horns and axles.

| Shelf Width/Length (in.) | Shelf Width/Length (mm) | 2-TIER MODELS | | 3-TIER MODELS | | | |
|--------------------------|-------------------------|-------------------------|-----------------------------|-------------------------|-----------------------------|------|-----------|
| | | Approx. Pkd. Wt. (lbs.) | Cat. No. Super Erecta Brite | Approx. Pkd. Wt. (lbs.) | Cat. No. Super Erecta Brite | | |
| 18x36 | 457x914 | 40 | 18 | 2SPN33ABR | 50 | 22.5 | 3SPN33ABR |
| 21x36 | 530x914 | 44 | 20 | 2SPN43ABR | 55 | 24.7 | 3SPN43ABR |
| 24x36 | 610x914 | 48 | 22 | 2SPN53ABR | 61 | 27.4 | 3SPN53ABR |
| 24x48 | 610x1219 | 54 | 24 | 2SPN55ABR | 70 | 31.5 | 3SPN55ABR |
| 24x60 | 610x1524 | 64 | 29 | 2SPN56ABR | 85 | 38.2 | 3SPN56ABR |

Chrome finish — 900 lbs. (410kg) capacity per cart

- 5MP Polyurethane Casters; casters have plated horns and axles.

| Shelf Width/Length (in.) | Shelf Width/Length (mm) | 2-TIER MODELS | | 3-TIER MODELS | | | |
|--------------------------|-------------------------|-------------------------|-----------------|-------------------------|-----------------|------|----------|
| | | Approx. Pkd. Wt. (lbs.) | Cat. No. Chrome | Approx. Pkd. Wt. (lbs.) | Cat. No. Chrome | | |
| 18x36 | 457x914 | 40 | 18 | 2SPN33DC | 50 | 22.5 | 3SPN33DC |
| 21x36 | 530x914 | 44 | 20 | 2SPN43DC | 55 | 24.7 | 3SPN43DC |
| 24x36 | 610x914 | 48 | 22 | 2SPN53DC | 61 | 27.4 | 3SPN53DC |
| 24x48 | 610x1219 | 54 | 24 | 2SPN55DC | 70 | 31.5 | 3SPN55DC |
| 24x60 | 610x1524 | 64 | 29 | 2SPN56DC | 85 | 38.2 | 3SPN56DC |

Type 304 Stainless Steel — 900 lbs. (410kg) capacity per cart

- 5PC Polyurethane Casters; casters have polymer horns and stainless steel axles.

| Shelf Width/Length (in.) | Shelf Width/Length (mm) | 2-TIER MODELS | | 3-TIER MODELS | | | |
|--------------------------|-------------------------|-------------------------|--------------------------|-------------------------|--------------------------|------|----------|
| | | Approx. Pkd. Wt. (lbs.) | Cat. No. Stainless Steel | Approx. Pkd. Wt. (lbs.) | Cat. No. Stainless Steel | | |
| 18x36 | 457x914 | 40 | 18 | 2SPN33PS | 50 | 22.5 | 3SPN33PS |
| 21x36 | 530x914 | 44 | 20 | 2SPN43PS | 55 | 24.7 | 3SPN43PS |
| 24x36 | 610x914 | 48 | 22 | 2SPN53PS | 61 | 27.4 | 3SPN53PS |
| 24x48 | 610x1219 | 54 | 24 | 2SPN55PS | 70 | 31.5 | 3SPN55PS |
| 24x60 | 610x1524 | 64 | 29 | 2SPN56PS | 85 | 38.2 | 3SPN56PS |

One-Piece Handles — {12.10}

May be used with Super Erecta shelving, casters, and components to customize a cart to your exact needs.

| Shelf Width/Length (in.) | Shelf Width/Length (mm) | Approx. Pkd. Wt. (lbs.) | Approx. Pkd. Wt. (kg) | Cat. No. Chrome | Cat. No. Stainless Steel |
|--------------------------|-------------------------|-------------------------|-----------------------|-----------------|--------------------------|
| 18 | 457 | 5 1/2 | 2.5 | H3C | H3S |
| 21 | 533 | 5 3/4 | 2.6 | H4C | H4S |
| 24 | 610 | 6 | 2.7 | H5C | H5S |

Height: 34.5" (876mm).



2-Tier with 5M casters



3-Tier with 5MP casters



3-Tier with 5PC casters



One-Piece Handle



Off-the-floor efficiency.



Bow-Tie Dunnage Rack

Bow-Tie™ Dunnage Racks — {9.09}

12" (305mm) high; 22" (559mm) wide.

- Metro Bow-Tie Dunnage Racks are available with built-in Microban® antimicrobial product protection to protect from bacteria, mold, mildew and fungi that cause odors, stains and product degradation. Standard models, without Microban, are also available.
- Rust and corrosion-proof polymer material.
- Helps protect floors: legs have a larger radius than traditional dunnage racks and distribute the storage load across a wider area.
- Racks join together easily without tools in "end-to-end" and "back-to-back" configurations with the exclusive Bow-Tie™ feature.
- Heavy-duty construction gives racks the strength to hold up to 1,500 lbs. (683kg) for 30" (760mm) and 36" (914mm) long racks, and 3,000 (1365kg) for 48" (1219mm) and 60" (1524mm) racks.

| Length (in.) | Length (mm) | Height (in.) | Height (mm) | Approx. Pkd. Wt. (lbs.) | Approx. Pkd. Wt. (kg) | Capacity (lbs.) | Capacity (kg) | Cat. No. Microban® | Cat. No. Standard |
|--------------|-------------|--------------|-------------|-------------------------|-----------------------|-----------------|---------------|--------------------|-------------------|
| 30 | 760 | 12 | 305 | 24 | 10.8 | 1500 | 68 | HP2230PDMB | HP2230PD |
| 36 | 914 | 12 | 305 | 26 | 11.7 | 1500 | 68 | HP2236PDMB | HP2236PD |
| 48 | 1219 | 12 | 305 | 34 | 15.3 | 3000 | 136 | HP2248PDMB | HP2248PD |
| 60 | 1524 | 12 | 305 | 42 | 19 | 3000 | 136 | HP2260PDMB | HP2260PD |

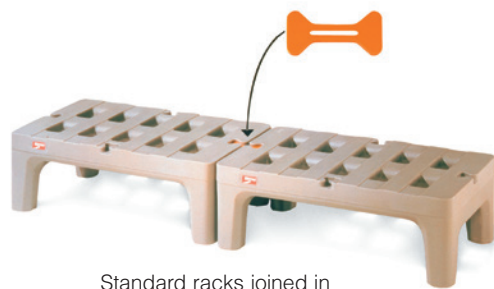

Standard racks joined in "end-to-end" configuration.

☑ Indicates antimicrobial product.



Dunnage Platforms (Standard Duty) — {10.44}

Space-saving platforms let you keep bulky items off the floor.

- Open wire provides air circulation and minimizes dust.
- All platforms use 13P or 13PS posts — height 14.63" (371mm) including cap and leveling bolt.

| Width/Length (in.) | Width/Length (mm) | Approx. Pkd. Wt. (lbs.) | Approx. Pkd. Wt. (kg) | Cat. No. Super Erecta Brite | Cat. No. Chrome | Cat. No. Stainless |
|--------------------|-------------------|-------------------------|-----------------------|-----------------------------|-----------------|--------------------|
| 18x24 | 457x610 | 11 | 5.0 | P1824BR | P1824NC | P1824NS |
| 18x30 | 457x760 | 12 | 5.5 | P1830BR | P1830NC | P1830NS |
| 18x36 | 457x914 | 13.5 | 6.1 | P1836BR | P1836NC | P1836NS |
| 21x24 | 530x610 | 12 | 5.5 | P2124BR | P2124NC | P2124NS |
| 21x30 | 530x760 | 13 | 5.9 | P2130BR | P2130NC | P2130NS |
| 21x36 | 530x914 | 15 | 6.8 | P2136BR | P2136NC | P2136NS |
| 24x24 | 610x610 | 13 | 5.9 | P2424BR | P2424NC | P2424NS |
| 24x30 | 610x760 | 15 | 6.8 | P2430BR | P2430NC | P2430NS |
| 24x36 | 610x914 | 17 | 7.7 | P2436BR | P2436NC | P2436NS |



Super Erecta Platform

Heavy-Duty Dunnage Racks — {10.46}

A space-efficient way to store large, bulky items off the floor.

- Removable top mat lifts off for cleaning.
- Dunnage racks are 14.5" (368mm) high including mat, cap and leveling bolt.

| Width/Length (in.) | Width/Length (mm) | Approx. Pkd. Wt. (lbs.) | Approx. Pkd. Wt. (kg) | Cat. No. Chrome | Cat. No. Metroseal Green with Microban® | Cat. No. Stainless |
|--------------------|-------------------|-------------------------|-----------------------|-----------------|---|--------------------|
| 18x24 | 457x610 | 22 | 10 | HP31C | HP31K3 | |
| 18x30 | 457x760 | 25 | 11 | HP32C | HP32K3 | |
| 18x36 | 457x914 | 30 | 13 | HP33C | HP33K3 | HP33S |
| 18x48 | 457x1219 | 38 | 17 | HP35C* | HP35K3* | HP35S* |
| 24x24 | 610x610 | 28 | 12 | HP51C | HP51K3 | |
| 24x30 | 610x760 | 30 | 14 | HP52C | HP52K3 | |
| 24x36 | 610x914 | 36 | 16 | HP53C | HP53K3 | HP53S |
| 24x48 | 610x1219 | 42 | 19 | HP55C* | HP55K3* | HP55S* |

Note: Maximum distributed static load capacity for stationary dunnage racks is 1,600 lbs. (725kg), except on units marked * which have a 1,300 lb. (590kg) capacity.



Dunnage Rack with Mat

Mobile Dunnage Racks (Heavy Duty) — {10.46}

These easy-to-manuever racks feature two swivel and two swivel/brake casters; with non-marking polyurethane tread.

- Support frames: 1" (25mm) square tubing.
- Removable wire mat: .313" (7.9mm) diameter wire.

| Width/Length (in.) | Width/Length (mm) | Approx. Pkd. Wt. (lbs.) | Approx. Pkd. Wt. (kg) | Cat. No. Chrome | Cat. No. Metroseal Green with Microban® | Cat. No. Stainless |
|--------------------|-------------------|-------------------------|-----------------------|-----------------|---|--------------------|
| 18x36 | 457x914 | 42 | 18.9 | MHP33C | MHP33K3 | MHP33S |
| 18x48 | 457x1219 | 50 | 22.5 | MHP35C | MHP35K3 | MHP35S |
| 24x36 | 610x914 | 48 | 21.6 | MHP53C | MHP53K3 | MHP53S |
| 24x48 | 610x1219 | 54 | 24.3 | MHP55C | MHP55K3 | MHP55S |

Maximum distributed static load capacity is 800 lbs. (363kg).

Note: These units are designed for only the 5HP and 5HPB casters, which are shipped assembled with the special posts.



Mobile Dunnage Rack shown in Metroseal Green finish

HD Super Duty Dunnage Racks

Stores more than a ton safely off the floor.

- 48" (1219mm) rack has a 3,000 pound (1361kg) static load capacity (uniformly distributed); 60" (1524mm) rack carries up to 2,400 pounds (1089kg).
- HD Super™ design features fast, secure assembly without tools.
- Posts of 1.625" (41mm) diameter provide greater rigidity.
- HD Super™ Dunnage Racks are 16.25" (413mm) high including cap and leveling bolt.

| Width/Length (in.) | Width/Length (mm) | Approx. Pkd. Wt. (lbs.) | Approx. Pkd. Wt. (kg) | Cat. No. Chrome |
|--------------------|-------------------|-------------------------|-----------------------|-----------------|
| 18x48 | 457x1219 | 52 | 23.4 | HDP35C |
| 18x60 | 457x1524 | 62 | 27.9 | HDP36C |
| 24x48 | 610x1219 | 57 | 26.6 | HDP55C |
| 24x60 | 610x1524 | 66 | 29.7 | HDP56C |

Maximum capacity 2,400 pounds (1089kg) uniformly distributed static load on the 60" (1524mm) length racks; 3,000 pounds (1361kg) on the 48" (1219mm) length racks.

Note: Capacity will be reduced and the unit will become less stable if the 3-sided frame is mounted higher than 6" (152mm) from the floor.



HD Super Dunnage Rack



☑ Indicates antimicrobial product.



**Work
smarter not
harder.**

PrepMate®

PREP TABLES & APPLICATION-BASED UNITS

Prep Tables & Application Based Units..... 156-167
PrepMate Prep Stations..... 158-159
SmartStation Application Based Units 160-167



LEARN MORE

By your side until the job is done.



SUPPORTS GOOD HACCP PROCESSES

*Patent Pending.



Versatile.

Prepare raw meats like chicken, pork, beef or seafood. Create an efficient versatile workspace using standard steam table and food pans.

Efficient.

From farm to table, chop, dice & slice through vegetables with the highest efficiency. Utilize the PrepMate rail system with stock below on one side and push prepped food directly into waiting pans on the other.



ADJUSTABLE
5 Working Heights

See it in action.
go.metro.com/prepmate

Boost Productivity.

Research shows space and workflow gains are undeniable. Up to a 20% increase in productivity during food processing using PrepMate compared to traditional methods.

Make it yours.



Drop-in totes with a magic ring or extended work surface.

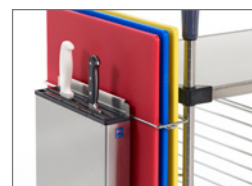

Keep cutting boards and knives right at hand.



Tools are easy to find with a utensil & towel bar.



Total lock casters create a stable, yet mobile workstation.

20% INCREASE



* Penn State University Center for Food Innovation testing.



PrepMate Multifunctional Prep Tables — {17.50}

| PrepMate Part # | Width/Length | Shelf Size | Top Shelf | Bottom Shelf |
|-----------------|----------------------------|--------------------------|-----------------------------|-----------------------------|
| MS1824-FGFG | 19.4"x26" (493mm x 660mm) | 18"x24" (457mm x 610mm) | Solid Galvanized | Solid Galvanized |
| MS1824-FGGBR | 19.4"x26" (493mm x 660mm) | 18"x24" (457mm x 610mm) | Solid Galvanized | Brite Zinc Wire |
| MS1824-FSFS | 19.4"x26" (493mm x 660mm) | 18"x24" (457mm x 610mm) | Solid Stainless Steel | Solid Stainless Steel |
| MS1824-FSNK | 19.4"x26" (493mm x 660mm) | 18"x24" (457mm x 610mm) | Solid Stainless Steel | Metroseal Green Epoxy Wire |
| MS1824-BRBR | 19.4"x26" (493mm x 660mm) | 18"x24" (457mm x 610mm) | Brite Zinc Wire | Brite Zinc Wire |
| MS1824-PRPR | 19.4"x26" (493mm x 660mm) | 18"x24" (457mm x 610mm) | Super Erecta Pro Hybrid Mat | Super Erecta Pro Hybrid Mat |
| MS1824-FSPR | 19.4"x26" (493mm x 660mm) | 18"x24" (457mm x 610mm) | Solid Stainless Steel | Super Erecta Pro Hybrid Mat |
| MS1824-NKNK | 19.4"x26" (493mm x 660mm) | 18"x24" (457mm x 610mm) | Metroseal Green Epoxy Wire | Metroseal Green Epoxy Wire |
| MS1830-FGFG | 19.4"x32" (493mm x 812mm) | 18"x30" (457mm x 762mm) | Solid Galvanized | Solid Galvanized |
| MS1830-FGGBR | 19.4"x32" (493mm x 812mm) | 18"x30" (457mm x 762mm) | Solid Galvanized | Brite Zinc Wire |
| MS1830-FSFS | 19.4"x32" (493mm x 812mm) | 18"x30" (457mm x 762mm) | Solid Stainless Steel | Solid Stainless Steel |
| MS1830-FSNK | 19.4"x32" (493mm x 812mm) | 18"x30" (457mm x 762mm) | Solid Stainless Steel | Metroseal Green Epoxy Wire |
| MS1830-BRBR | 19.4"x32" (493mm x 812mm) | 18"x30" (457mm x 762mm) | Brite Zinc Wire | Brite Zinc Wire |
| MS1830-PRPR | 19.4"x32" (493mm x 812mm) | 18"x30" (457mm x 762mm) | Super Erecta Pro Hybrid Mat | Super Erecta Pro Hybrid Mat |
| MS1830-FSPR | 19.4"x32" (493mm x 812mm) | 18"x30" (457mm x 762mm) | Solid Stainless Steel | Super Erecta Pro Hybrid Mat |
| MS1830-NKNK | 19.4"x32" (493mm x 812mm) | 18"x30" (457mm x 762mm) | Metroseal Green Epoxy Wire | Metroseal Green Epoxy Wire |
| MS1836-FGFG | 19.4"x38" (493mm x 914mm) | 18"x36" (457mm x 914mm) | Solid Galvanized | Solid Galvanized |
| MS1836-FGGBR | 19.4"x38" (493mm x 914mm) | 18"x36" (457mm x 914mm) | Solid Galvanized | Brite Zinc Wire |
| MS1836-FSFS | 19.4"x38" (493mm x 914mm) | 18"x36" (457mm x 914mm) | Solid Stainless Steel | Solid Stainless Steel |
| MS1836-FSNK | 19.4"x38" (493mm x 914mm) | 18"x36" (457mm x 914mm) | Solid Stainless Steel | Metroseal Green Epoxy Wire |
| MS1836-BRBR | 19.4"x38" (493mm x 914mm) | 18"x36" (457mm x 914mm) | Brite Zinc Wire | Brite Zinc Wire |
| MS1836-PRPR | 19.4"x38" (493mm x 914mm) | 18"x36" (457mm x 914mm) | Super Erecta Pro Hybrid Mat | Super Erecta Pro Hybrid Mat |
| MS1836-FSPR | 19.4"x38" (493mm x 914mm) | 18"x36" (457mm x 914mm) | Solid Stainless Steel | Super Erecta Pro Hybrid Mat |
| MS1836-NKNK | 19.4"x38" (493mm x 914mm) | 18"x36" (457mm x 914mm) | Metroseal Green Epoxy Wire | Metroseal Green Epoxy Wire |
| MS1848-FGFG | 19.4"x50" (493mm x 1270mm) | 18"x48" (457mm x 1219mm) | Solid Galvanized | Solid Galvanized |
| MS1848-FGGBR | 19.4"x50" (493mm x 1270mm) | 18"x48" (457mm x 1219mm) | Solid Galvanized | Brite Zinc Wire |
| MS1848-FSFS | 19.4"x50" (493mm x 1270mm) | 18"x48" (457mm x 1219mm) | Solid Stainless Steel | Solid Stainless Steel |
| MS1848-FSNK | 19.4"x50" (493mm x 1270mm) | 18"x48" (457mm x 1219mm) | Solid Stainless Steel | Metroseal Green Epoxy Wire |
| MS1848-BRBR | 19.4"x50" (493mm x 1270mm) | 18"x48" (457mm x 1219mm) | Brite Zinc Wire | Brite Zinc Wire |
| MS1848-PRPR | 19.4"x50" (493mm x 1270mm) | 18"x48" (457mm x 1219mm) | Super Erecta Pro Hybrid Mat | Super Erecta Pro Hybrid Mat |
| MS1848-FSPR | 19.4"x50" (493mm x 1270mm) | 18"x48" (457mm x 1219mm) | Solid Stainless Steel | Super Erecta Pro Hybrid Mat |
| MS1848-NKNK | 19.4"x50" (493mm x 1270mm) | 18"x48" (457mm x 1219mm) | Metroseal Green Epoxy Wire | Metroseal Green Epoxy Wire |



| Part # | Shelf Types |
|-----------------|-----------------------|
| MS1830-FSFS-PK2 | Stainless / Stainless |
| MS1836-FSFS-PK2 | Stainless / Stainless |
| MS1848-FSFS-PK2 | Stainless / Stainless |

Includes all accessories shown.



| Part # | Shelf Types |
|------------------|--------------------|
| MS1830-FGGBR-PK2 | Galvanized / Brite |
| MS1836-FGGBR-PK2 | Galvanized / Brite |
| MS1848-FGGBR-PK2 | Galvanized / Brite |

Includes all accessories shown.



| Part # | Shelf Types |
|-----------------|-------------|
| MS1830-PRPR-PK2 | Pro / Pro |
| MS1836-PRPR-PK2 | Pro / Pro |
| MS1848-PRPR-PK2 | Pro / Pro |

Includes all accessories shown.

PrepMate Accessories & Accessory Kits

| Part # | Description | Size |
|-------------|--------------------------|--|
| MS-CBE | Cutting Board Holder | 18.75"x19.25"x5" (476mm x 489mm x 127mm) |
| MS-CB1824-W | Cutting Board | 18"x24" (457mm x 610mm x 12.7mm) |
| MS-RING | Magic Ring | 7"x13" (178mm x 330mm) |
| MS-CSBH | Sanitation Bucket Holder | 7"x13" (178mm x 330mm) |
| MS-SPH* | Pan Holder | 19"x22.5"x16" (483mm x 572mm x 406mm) |
| MS-KNIFE | Encased Knife Holder | 2"x10"x12" (51mm x 254mm x 305mm) |
| MS-UB | 18" Utensil Bar | 3"x18" (76mm x 457mm) |
| 5PTL-NB | 5" Total Lock Caster | 5" (127mm) |

| Kit Part # | Accessory Kit Description | MS 1836 - FS FS - PK1 |
|------------|--|-----------------------|
| PK1 | (2) Magic Ring Accessories (1) 18"x24"x.5" White HDPE Cutting Board | |
| PK2 | (2) Magic Rings, (1) 18"x24"x.5" White HDPE Cutting Board, Cuttingboard Holder, Pan Holder, Knife Holder | |

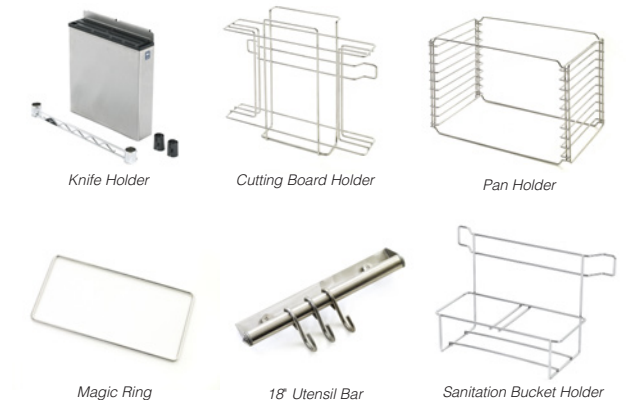

*Note: Not compatible with 18"x24" units. Kits can only be ordered with a PrepMate Unit. Kit part # should be added to the end of the PrepMate part #.



Perfect for the task at hand.

These smart solutions make improving efficiency & productivity a snap!

Metro Smart Solutions bundle unique configurations designed to address the most common issues...all ready for you. Save time creating custom solutions and solve common issues with, preconfigured, ready-to-ship solutions.

Complete kits for easy ordering.



Easy-to-order.



Preconfigured.



Proven Solutions.

Metro Breakfast Cart

- Includes eye catching two-sided sign
- Type 304 stainless steel top for easy cleaning



Complete Kit Includes:

(1) 2-Sided Sign, (1) Stainless Steel Top (1) Hanger rail, (2) Wire Shelves (4) Casters, 2-Swivel/2-Brake (2) Lower posts, (2) High Back Posts

| Description | Height (in.) | Height (mm) | Cat. No. |
|--|--------------|-------------|----------|
| 24 x 36 Stainless steel top with adjustable middle shelf | 70 | 1178 | GG2436 |
| 24 x 48 Stainless steel top with adjustable middle shelf | 70 | 1178 | GG2448 |
| 24 x 60 Stainless steel top with adjustable middle shelf | 70 | 1178 | GG2460 |

Note: Comes with 2-sided sign.



To-go & Order Pickup Solutions



Pickup Station

- Eliminate congestion around counterspaces in the front-of-house while offering a convenient designated spot to pick up orders.
- Organize and alphabetize orders by utilizing label holders.

Complete Kit Includes:

(4) Black Epoxy Posts, (5) Black Epoxy Super Erecta Shelves, (1) Hanger Rail, (5) Clear Inlays, (5) Label Holders, (1) Pickup Sign with Hardware for Assembly

| Description | Size (in) (W x L x H) | Size (mm) (W x L x H) | Cat. No. |
|----------------------|-----------------------|-----------------------|------------|
| 18x24 Pickup Station | 18x24x54 | 457x610x1372 | CR1824TGSR |
| 18x36 Pickup Station | 18x36x54 | 457x914x1372 | CR1836TGSR |
| 18x48 Pickup Station | 18x48x54 | 457x1219x1372 | CR1848TGSR |

*Total Height including sign: 62.25" (1581mm)



Countertop Pickup Station

- Utilize countertop space to stage orders for pickup.
- Organize and alphabetize orders by utilizing label holders.

Complete Kit Includes:

(4) Black Epoxy Posts, (2 or 3*) Black Epoxy Super Erecta Shelves, (1) Hanger Rail, (2 or 3*) Clear Inlays, (2 or 3*) Label Holders, (1) Pickup Sign with Hardware for Assembly
*Number of shelves, inlays, and label holders is dependent on model number selected.

| Description | Size (in) (W x L x H) | Size (mm) (W x L x H) | Cat. No. |
|---------------------------------|-----------------------|-----------------------|------------|
| 2 Bay Countertop Pickup Station | 18x24x27.75 | 457x610x707 | CR1824TG2B |
| 3 Bay Countertop Pickup Station | 18x24x42.5 | 457x610x1080 | CR1824TG3B |



To-Go Station

- qwikSLOT Drop Mat shelves angle packaged orders forward to improve visibility and accessibility while keeping them secure.
- Organize and alphabetize orders by utilizing label holders.

Complete Kit Includes:

(4) Black Epoxy Posts, (4) Black Epoxy qwikSLOT Drop Mat Shelves, (2) Black Epoxy Drop Mat Super Erecta Shelves, (2) Hanger Rails, (6) Shelf Inlays, (5) Label Holders

| Description | Size (in) (W x L x H) | Size (mm) (W x L x H) | Cat. No. |
|------------------------|-----------------------|-----------------------|------------|
| qwikSLOT To-Go Station | 18x36x63 | 457x914x1600 | CR1836TGPU |

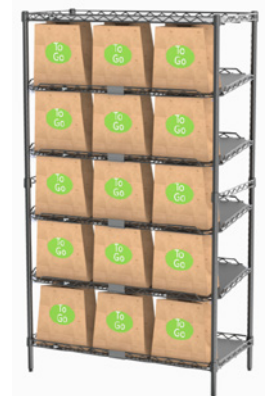

MetroMax Q Cart

- Easily transport bulk items and food to the curbside, classroom, and beyond with this MetroMax Q Mobile Cart.
- Removable grid mats make cleaning easy and include built-in Microban antimicrobial protection to keep your unit cleaner in between cleanings.

Complete Kit Includes:

(4) Mobile Polymer Posts, (4) MetroMax Q Shelves, (4) Brake/Swivel Casters, (2) Easy-Grip Handles
*Mightylite and Mightylite Dollies pictured are sold separately.

| Description | Size (in) (W x L x H) | Size (mm) (W x L x H) | Cat. No. |
|------------------------------|-----------------------|-----------------------|---------------|
| MetroMax Q Cart with Handles | 26.5x80x67.25 | 673x2032x1708 | CR247263-MQC4 |





Drive-thru Solutions



Order Staging Cart

- Easily stage and assemble orders for pickup.
- Bin holders conveniently hold condiments, utensils, and other order add-ons at an ergonomic working height for easy assembly.

Complete Kit Includes:

(4) Chrome Posts, (2) Swivel Casters, (2) Brake Casters, (2) Chrome Super Erecta Shelves, (1) Solid Stainless Shelf, (2) Cantilever Shelves, (1) Bin Holder, (5 or 8*) Black Bins
 *Number of black bins are dependent on model number selected.

| Description | Size (in) (W x L x H) | Size (mm) (W x L x H) | Cat. No. |
|--------------------------|--------------------------|--------------------------|-----------|
| 24x30 Order Staging Cart | 27.75 x 31.75 x 65.75 | 707 x 809 x 1673 | CR2430DSS |
| 24x48 Order Staging Cart | 27.75 x 49.75 x 65.75 | 707 x 1245 x 1673 | CR2448DSS |



Drive-thru Workstation

- Assemble, then stage orders until they are handed off to the customer.
- A wire grid allows you to customize your accessory selection and tailor your unit to your specific application while improving efficiency.

Complete Kit Includes:

(4) Chrome Posts, (3) Chrome Super Erecta Shelves, (2) Single Shelf Supports, (1) Solid Stainless Shelf, (1) Cash Drawer Bracket, (1) Wire Grid, (2) Hanger Rails, (4) S-Hooks
 *Black bins and SmartWall accessories are sold separately.

| Description | Size (in) (W x L x H) | Size (mm) (W x L x H) | Cat. No. |
|--|--------------------------|--------------------------|-----------|
| 24x48 Workstation with Cash Drawer Bracket | 24 x 48 x 64.5 | 610 x 1219 x 1638 | CR2448GDT |
| 24x60 Workstation with Cash Drawer Bracket | 24 x 60 x 64.5 | 610 x 1524 x 1638 | CR2460GDT |



POS Assembly Workstation

- Streamline order assembly and prevent human error while ensuring customer satisfaction.
- Keep packaging, condiments, and utensils within arm's reach.

Complete Kit Includes:

(4) Chrome Posts, (3) Brite Super Erecta Shelves, (1) Solid Stainless Shelf, (3) Bin Holders, (15) Black Bins, (15) Bin Dividers
 *POS system not included.

| Description | Size (in) (W x L x H) | Size (mm) (W x L x H) | Cat. No. |
|--------------------------------|--------------------------|--------------------------|-------------|
| 24x30 POS Assembly Workstation | 24x30x74 | 457x914x1880 | CR2430DTPOS |



Drive-thru Order Staging Cart

- Organize and stage orders for pickup and carryout in one small, mobile footprint.
- The solid stainless steel work surface has a customized inlay to signify when an order is ready to serve.

Complete Kit Includes:

(4) Chrome Posts, (2) Brake Casters, (2) Brake/Swivel Casters, (2) Brite Super Erecta Shelves, (1) Solid Stainless Shelf with Custom Inlay

| Description | Size (in) (W x L x H) | Size (mm) (W x L x H) | Cat. No. |
|--------------------------|--------------------------|--------------------------|-------------|
| 14x30 Order Staging Cart | 14x30x29 | 356x762x737 | CR1430DTOSC |

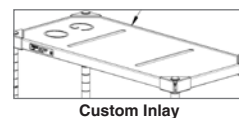

Prep Workstation with Super Erecta® Hot Shelving

- Prepare orders and keep them hot in one location.
- A 30" deep work surface provides a spacious area for order prep.
- Stage orders overhead on Super Erecta Heated Shelving before they are ready for pickup to keep meals at safe temperatures.

Complete Kit Includes:

(6) Chrome Posts, (2) Chrome Super Erecta Shelves, (1) Solid Stainless Shelf, (2) Heated Shelves, (1) Brite Wire Grid, (2) Hanger Rails, (4) S-Hooks, (2) Foot Covers, (1) Utensil Cylinder, (1) Cylinder Holder, (1) Small Shelf, (2 or 4*) Bin Holders, (2 or 4*) Black Bins
 *Number of bin holders and black bins are dependent on model number selected.

| Description | Size (in) (W x L x H) | Size (mm) (W x L x H) | Cat. No. |
|---|--------------------------|--------------------------|------------|
| 30x36 Prep Workstation with Overhead Heat | 30x36x62.7 | 762x914x1588 | CRHSP-3036 |
| 30x48 Prep Workstation with Overhead Heat | 30x48x62.5 | 762x1219x1588 | CRHSP-3048 |
| 30x60 Prep Workstation with Overhead Heat | 30x60x62.5 | 762x1524x1588 | CRHSP-3060 |



Countertop Condiment Tower

- Maximize counter space and keep small order add-ons such as condiment packets, utensils, napkins, straws, etc. within arm's reach.
- The 3-sided double snake frame allows for easy access to bin contents and provides stability. No need to reach around posts.

Complete Kit Includes:

(4) Chrome Posts, (4) Hanger rails, (2) Front Legs (1) 3-Sided Frame, (4) Bin Holders, (12) Black Bins, (12) Bin Dividers

| Description | Size (in) (W x L x H) | Size (mm) (W x L x H) | Cat. No. |
|----------------------------------|--------------------------|--------------------------|------------|
| 18X24 Countertop Condiment Tower | 18x24x27 | 457x610x686 | CR1824DTCT |



Food Prep



All-in-One Prep Station

- Increase the speed and accuracy of food prep.
- The unit comes equipped with SmartWall and SmartWall accessories to keep condiments, utensils, and spices within arms reach.

Complete Kit Includes:

(6) Metroseal Green Super Erecta Shelf, (1) Solid Stainless Shelf, (1) Metroseal Green Wire Grid, (4) Prong Hooks, (1) Small Basket, (1) Glove Box Holder, (1) Small Utensil Holder, (4) S-Hooks, (3) Hanger Rails, (2) Foot Covers, (1) 3-Sided Frame, (1) Light Duty Shelf

| Description | Size (in) (W x L x H) | Size (mm) (W x L x H) | Cat. No. |
|-------------------------------|--------------------------|--------------------------|-----------|
| 18x48 All-in-One Prep Station | 18x48x63 | 457x1219x1600 | CR1848AIO |
| 24x48 All-in-One Prep Station | 24 x 48 x 63 | 610 x 1219 x 1600 | CR2448AIO |



*Mightylites Not Included

SmartWall Prep Unit

- No room for a floor based prep unit? Utilize wall space!
- SmartWall accessories most common for food prep are included.

Complete Kit Includes:

(1) 40" Wall Track, (2) 30" Uprights, (1) Metroseal Green Wire Grid, (2) Single Shelf Supports, (1) Metroseal Green Super Erecta Shelf, (1) Drying Shelf, (2) Storage Baskets, (1) Utensil Cylinder, (1) Cylinder Holder, (6) Prong Hooks, (2) Standard Hooks

| Description | Size (in) (W x L x H) | Size (mm) (W x L x H) | Cat. No. |
|---------------------|--------------------------|--------------------------|------------|
| SmartWall Prep Unit | 20.5x40x31.75 | 521x1016x806 | CR36SWPREP |





Prep Table with SmartWall & Cart

- Get a complete prep unit right out of the box.
- This unit has all you need to store, prep, stage to-go orders, and move food.
- Using a 3-sided frame adds stability, and creates a nesting area for the cart.

Complete Kit Includes:

(1) Wall Track, (2) Uprights, (1) Metroseal Green Wire Grid, (2) Single Shelf Supports, (2) Metroseal Green Super Erecta Shelves, (1) Glove Box Holder, (1) Storage Basket, (1) Utensil Cylinder, (1) Cylinder Holder, (3) Prong Hooks, (8) Metroseal Green Posts, (2) Solid Stainless Shelves, (1) 3-Sided Frame, (2) Swivel Casters, (2) Brake Casters

| Description | Size (in) (W x L x H) | Size (mm) (W x L x H) | Cat. No. |
|----------------------------------|--------------------------|--------------------------|------------|
| Prep Table with SmartWall & Cart | 36x40x70.5 | 914x1016x1791 | CR2436PTSW |

Pizza Prep SmartWall Unit

- Utilize wall space to create a less cluttered worktable surface.
- This unit has all you need to prep pizzas and get them ready for the oven.

Complete Kit Includes:

(1) Metroseal Gray Wire Grid, (1) Wall Track, (2) Uprights, (2) Single Shelf Supports, (1) Metroseal Gray Super Erecta Shelf (1) Bottle Holder, (1) 1/3 Pan Holder, (1) Spice Rack, (1) Glove Box Holder, (1) Light Duty Shelf, (4) Prong Hooks

| Description | Size (in) (W x L x H) | Size (mm) (W x L x H) | Cat. No. |
|---------------------------|--------------------------|--------------------------|------------------|
| SmartWall Pizza Prep Unit | 20x36x35 | 508x914x889 | SWKIT-PIZZAPREP4 |



Front Counter & Dry Storage Solutions



Condiment Cart

- Keep small order add-ons in close proximity to pickup stations.
- Removable black bins organize condiments, utensils, napkins, etc. and offer peace of mind for sanitizing and cleaning.

Complete Kit Includes:

(4) Chrome Posts, (2) Swivel Casters, (2) Brake Casters, (1) Brite Super Erecta Shelf, (1) Solid Stainless Shelf, (3) Bin Holders, (12) Black Bins

| Description | Size (in) (W x L x H) | Size (mm) (W x L x H) | Cat. No. |
|-----------------------------|--------------------------|--------------------------|----------|
| 14x30 Mobile Condiment Cart | 14x30x27 | 356x762x686 | CR1430CC |



Under Counter Condiment Cart

- Nest the unit under counter to save space in the back-of-house.
- Keep small order add-ons in close proximity to pick-up stations.
- Removable black bins organize condiments, utensils, napkins, etc. and offer peace of mind for sanitizing and cleaning.

Complete Kit Includes:

(4) Chrome Posts, (4) Casters with Bumpers, (3) Chrome Drop Mat Super Erecta Shelves, (3) Bin Stoppers, (12) Black Bins

| Description | Size (in) (W x L x H) | Size (mm) (W x L x H) | Cat. No. |
|------------------------------------|--------------------------|--------------------------|-----------|
| 18x24 Under Counter Condiment Cart | 18x24x20 | 457x610x508 | CR1824CCU |



Under Counter Cup Cart

- Organize and efficiently store to-go cups in one small footprint.
- Nest the unit under counter to save space in the back-of-house.
- Dividers are included to organize cups by various sizes.

Complete Kit Includes:

(4) Chrome Posts, (2) Swivel Casters, (2) Brake Casters, (1) Chrome Super Erecta Shelf, (3) 30" Chrome Dividers, (1) 4-Sided Single Snake Frame, (2) 15x27 Chrome Wire Grids with Attachment Hardware, (1) 15x12 Chrome Wire Grid with Attachment Hardware

| Description | Size (in) (W x L x H) | Size (mm) (W x L x H) | Cat. No. |
|------------------------------|--------------------------|--------------------------|-----------|
| 18x30 Under Counter Cup Cart | 18x30x15 | 457x762x381 | CR1830CSU |



Overhead Cup Storage

- Organize and efficiently store to-go cups in one small footprint.
- Make the most out of underutilized wall space to keep cups organized and within arms reach.
- Dividers are included to organize cups by various sizes.

Complete Kit Includes:

(2) Wall Mount Brackets, (1) Chrome Super Erecta Shelf, (3) 24" Chrome Dividers, (1) 18" Horizontal Chrome Divider

| Description | Size (in) (W x L x H) | Size (mm) (W x L x H) | Cat. No. |
|---------------------------------|--------------------------|--------------------------|-----------|
| 24x30 Overhead Cup Storage Unit | 24x30x30 | 610x762x762 | CR2430OHC |

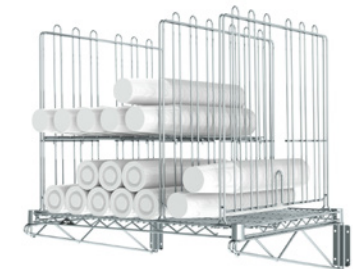

Dish Area & Drying



Mobile Utensil Rack

- Safely hang utensils to air dry on prong hooks with proper air circulation without worrying about bacteria growth.

Complete Kit Includes:

(4) Metroseal Green Posts, (2) Swivel Casters, (2) Brake Casters, (2) Metroseal Green Super Erecta Shelves, (4) Metroseal Green Wire Grids, (20) Prong Hooks, (14) Security S-Hooks, (16) Clamp Assemblies, (1) 3-Sided Frame

| Description | Size (in) (W x L x H) | Size (mm) (W x L x H) | Cat. No. |
|---------------------------------------|--------------------------|--------------------------|----------------|
| 18x36 Utensil Rack in Metroseal Green | 18x36x70 | 457x914x1778 | CR183670-UTNK3 |

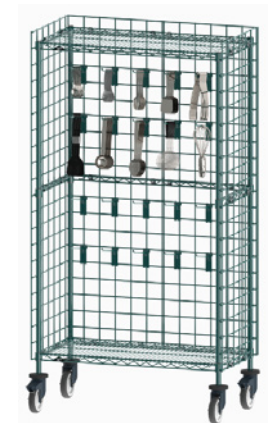

SmartWall Dish Tank Unit

- Make the most out of every inch by maximizing the wall space above the sink with this 72" SmartWall productivity system.
- Utilize vertical space to hang dry items, preventing wet-nesting.

Complete Kit Includes:

(2) Wall Tracks, (4) Uprights, (4) Single Shelf Supports, (2) Metroseal Green Super Erecta Pro Shelves, (2) Metroseal Green Wire Grids, (2) Lid Storage Racks, (6) Cylinder Holders, (2) Deep Storage Baskets, (12) Prong Hooks

| Description | Size (in) (W x L x H) | Size (mm) (W x L x H) | Cat. No. |
|-----------------------------------|--------------------------|--------------------------|-----------|
| 21x80 Dish Tank Unit in Metroseal | 20.5x80x37 | 521x2032x940 | CR3COMP72 |

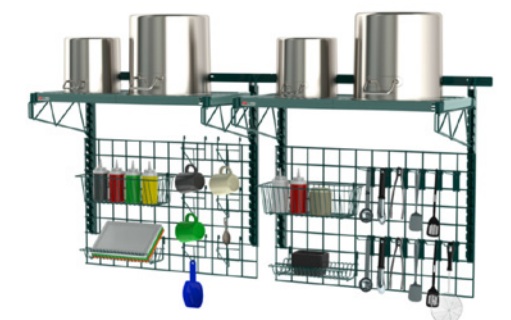



Cooler & Freezer



Docking Stations

- Ensure vertical storage space is maximized in the cooler/freezer, or anywhere overhead storage is needed, by using Docking Stations with 3-sided frames.
- Overhead Super Erecta Pro Shelves have easy-to-clean mats that can be removed in sections during cleaning without having to unload contents.

Complete Kit Includes:

(4) Metroseal Green Posts, (2) Super Erecta Pro Shelves, (2) 3-Sided Frames

| Description | Size (in) (W x L x H) | Size (mm) (W x L x H) | Cat. No. |
|---------------------------|--------------------------|--------------------------|---------------------|
| 24x24 NK3 Docking Station | 24X24X74 | 610x610x1880 | CR242474PRH2 |
| 24x30 NK3 Docking Station | 24X30X74 | 610x762x1880 | CR243074PRH2 |
| 24x36 NK3 Docking Station | 24X36X74 | 610x914x1880 | CR243674PRH2 |
| 24x42 NK3 Docking Station | 24X42X74 | 610x1067x1880 | CR244274PRH2 |
| 24x48 NK3 Docking Station | 24X48X74 | 610x1219x1880 | CR244874PRH2 |
| 24x54 NK3 Docking Station | 24X54X74 | 610x1372x1880 | CR245474PRH2 |
| 24x60 NK3 Docking Station | 24X60X74 | 610x1524x1880 | CR246074PRH2 |
| 24x72 NK3 Docking Station | 24X72X74 | 610x1829x1880 | CR247274PRH2 |



*Pan Racks Not Included.

Manager's Area



Manager's Station

- Keep Manager's items contained in one area to get more work done.
- Overhead locking capabilities protects valuable materials.
- SmartWall accessories organize loose items.

Complete Kit Includes:

(4) Chrome Posts, (4) S-Hooks, (2) BRITE Super Erecta Shelves, (1) 3-Sided Frame, (1) Solid Stainless Shelf, (1) Wire Grid, (1) Hanger Rail, (1) Security Module with Swinging Door, (4) Grid Hooks, (2) Flatware Cylinders, (2) Cylinder Holders, (2) Grid Shelves, (2) Catalog Holders, (2) Black Bins, (4) Single Bin Holders

| Description | Size (in) (W x L x H) | Size (mm) (W x L x H) | Cat. No. |
|-------------------------|--------------------------|--------------------------|------------------|
| 24x48 Manager's Station | 24x48x80 | 610x1219x2032 | CR2448MGR |



SmartWall Manager's Station

- Limited floor space? No problem.
- This wall storage work area houses all the items needed to plan and get the work done in a Foodservice operation.

Complete Kit Includes:

(1) Wall Track, (2) Uprights, (1) Wire Grid, (3) Chrome Super Erecta Shelves, (2) Single Shelf Supports, (2) Direct Wall Mounts, (4) Prong Hooks, (1) Flatware Cylinder, (1) Cylinder Holder, (1) Grid Shelf, (2) Catalog Holders, (2) Black Bins, (1) Retractable Keyboard Tray, (1) Shelf Inlay, (4) Shelf Collar Plugs

| Description | Size (in) (W x L x H) | Size (mm) (W x L x H) | Cat. No. |
|------------------------------------|--------------------------|--------------------------|----------------|
| 18x24 Under Counter Condiment Cart | 18x24x20 | 457x610x508 | CRMGRSW |



Can Storage Racks



4-Shelf MetroMax Q Can Rack

- Rust-resistant MetroMax Q unit for heavy-duty large can storage.
- Each wire can rack holder is gravity feed for 8 #10 cans or 12 #5 cans
- Polymer mats are easily removable and cleanable in sinks or commercial

Complete Kit Includes:

(4) Epoxy-coated Steel Posts, (4) MetroMax Q Shelves, (12 or 15) Wire Can Holders

| Description | Size (in) (W x L x H) | Size (mm) (W x L x H) | Cat. No. |
|-----------------------------------|--------------------------|--------------------------|-------------------|
| 24x36 MetroMax Q 96 #10 Can Rack | 24x36x74 | 610x914x1880 | MQCR243674 |
| 24x36 MetroMax Q 120 #10 Can Rack | 24x48x74 | 610x1219x1880 | MQCR244874 |



2-Shelf MetroMax Q Can Rack with Roll Under

- Rust-resistant MetroMax Q unit for heavy-duty large can storage.
- Each wire can rack holder is gravity feed for 8 #10 cans or 12 #5 cans
- Bottom section remains open for equipment, ingredient bins or utility carts.
- Polymer mats are easily removable and cleanable in sinks or commercial

Complete Kit Includes:

(4) Epoxy-coated Steel Posts, (2) MetroMax Q Shelves, (1) 3-sided Frame, (8 or 10) Wire Can Holders

| Description | Size (in) (W x L x H) | Size (mm) (W x L x H) | Cat. No. |
|---|--------------------------|--------------------------|----------------------|
| 24x36 MetroMax Q 64 #10 Can Rack with under storage | 24x36x74 | 610x914x1880 | MQCR243674-RU |
| 24x36 MetroMax Q 80 #10 Can Rack with under storage | 24x48x74 | 610x1219x1880 | MQCR243674-RU |



*Prepate Not Included



Metro Smart Solutions bundle unique configurations designed to address the most common issues...all ready for you.

For the most updated offering of application-based configurations scan QR code.



Easy-to-order.



Preconfigured.



Proven Solutions.



Ready and waiting.



Super Erecta® Hot
Metro2Go™
Mightylite®

FOOD WARMING & INSULATED CARRIERS

| | |
|--|----------------|
| Food Warming & Insulated Carriers | 168-177 |
| Super Erecta Hot Heated Shelving | 170-171 |
| Metro2Go Hot Stations | 172-173 |
| Mightylite Front Load Pan Carriers..... | 174-175 |
| Mightylite Top Load Pan Carriers | 176 |
| Mightylite Accessories | 177 |



Super **hot.**
Super flexible.



Fits any Super Erecta shelving unit or workstation.



Super Erecta Hot Shelves — {15.01}

Includes shelf, one bag of split sleeves and (4) plastic feet (posts not included). For actual dimensions add 5/8" (16mm) to depth and subtract 1/16" (2mm) from length.

| | 120V Model No. & Electrical Specifications (NEMA 5-15P plug) | Nominal Depth x Length | |
|--------|--|------------------------|----------|
| | | (in.) | (mm) |
| HS1424 | 120V, 200W, 1.7A | 14x24 | 356x610 |
| HS1430 | 120V, 200W, 1.7A | 14x30 | 356x762 |
| HS1436 | 120V, 400W, 3.4A | 14x36 | 356x914 |
| HS1442 | 120V, 400W, 3.4A | 14x42 | 356x1067 |
| HS1448 | 120V, 400W, 3.4A | 14x48 | 356x1219 |
| HS1460 | 120V, 600W, 5.0A | 14x60 | 356x1524 |
| HS1824 | 120V, 200W, 1.7A | 18x24 | 457x610 |
| HS1830 | 120V, 200W, 1.7A | 18x30 | 457x762 |
| HS1836 | 120V, 400W, 3.4A | 18x36 | 457x914 |
| HS1842 | 120V, 400W, 3.4A | 18x42 | 457x1067 |
| HS1848 | 120V, 400W, 3.4A | 18x48 | 457x1219 |
| HS1860 | 120V, 600W, 5.0A | 18x60 | 457x1524 |
| HS2424 | 120V, 200W, 1.7A | 24x24 | 610x610 |
| HS2430 | 120V, 400W, 3.4A | 24x30 | 610x762 |
| HS2436 | 120V, 400W, 3.4A | 24x36 | 610x914 |
| HS2442 | 120V, 600W, 5.0A | 24x42 | 610x1067 |
| HS2448 | 120V, 600W, 5.0A | 24x48 | 610x1219 |
| HS2460 | 120V, 800W, 6.7A | 24x60 | 610x1524 |



Use with Super Erecta Posts or Countertop Feet.

Super Erecta Hot Shelving — {15.01}

Consistent Heat Distribution: High quality, Type 304 stainless steel construction combined with aluminum inner core for consistent, reliable radiant heat across each shelf. Adjustable thermostat, 200°F (93°C) maximum surface temperature.

Low Wattage Design: Requires less power to operate and lower energy consumption.

Adjustability: Shelves can be adjusted at 1" (25mm) increments to customize to desired shelf spacing. Compatible with all Super Erecta SiteSelect posts

Cleanable and Durable: Smooth corrosion resistant stainless steel surfaces are easy-to-clean and durable to stand up to daily usage.

Plastic feet included with every shelf. Posts ordered separately.



Customize your spacing with adjustable shelves.



Adjustable in 1" increments (25mm)

Enclosed Shelf Kits — {15.01}

Includes heated shelf, non-heated stainless shelf, side panels, hinged doors on control side, sliding doors on opposite side, and split sleeves for each shelf (posts not included)

| | 120V Model No. & Electrical Specifications (NEMA 5-15P plug) | Dimensions Length x Depth x Height | | |
|-------------|--|------------------------------------|--------------|--|
| | | (in.) | (mm) | |
| HS1436-EKIT | 120V, 400W, 3.4A | 36.7x17.7x17.4 | 933x450x442 | |
| HS1442-EKIT | 120V, 400W, 3.4A | 42.7x17.7x17.4 | 1085x450x442 | |
| HS1448-EKIT | 120V, 400W, 3.4A | 48.7x17.7x17.4 | 1237x450x442 | |
| HS1836-EKIT | 120V, 400W, 3.4A | 36.7x 21.7x17.4 | 933x552x442 | |
| HS1842-EKIT | 120V, 400W, 3.4A | 42.7x 21.7x17.4 | 1085x552x442 | |
| HS1848-EKIT | 120V, 400W, 3.4A | 48.7x21.7 x17.4 | 1237x552x442 | |
| HS2436-EKIT | 120V, 400W, 3.4A | 36.7x27.7 x17.4 | 933x704x442 | |
| HS2442-EKIT | 120V, 600W, 5.0A | 42.7x 27.7x17.4 | 1085x704x442 | |
| HS2448-EKIT | 120V, 600W, 5.0A | 48.7x 27.7x17.4 | 1237x704x442 | |



Workstations with Open Heated Over Shelf

Includes 24" deep stainless steel work surface, 3 sided open frame to allow under counter storage, stationary posts, and 14" deep overhead heated & wire shelves.

| | 120V Model No. & Electrical Specifications (NEMA 5-15P plug) | Nominal Length x Depth x Height | |
|-------------|--|---------------------------------|---------------|
| | | (in.) | (mm) |
| EZHS36W-KIT | 120V, 400W, 3.4A | 36x24x64 | 914x610x1613 |
| EZHS48W-KIT | 120V, 400W, 3.4A | 48x24x64 | 1217x610x1613 |
| EZHS60W-KIT | 120V, 600W, 5.0A | 60x24x64 | 1522x610x1613 |



Workstations with Enclosed Heated Over Shelf

Includes 24" deep stainless steel work surface, 3 sided open frame to allow under counter storage, stationary posts, and 14" deep overhead enclosed heated shelf.

| | 120V Model No. & Electrical Specifications (NEMA 5-15P plug) | Nominal Length x Depth x Height | |
|--------------|--|---------------------------------|---------------|
| | | (in.) | (mm) |
| EZHSE36W-KIT | 120V, 400W, 3.4A | 36x24x64 | 914x610x1613 |
| EZHSE48W-KIT | 120V, 400W, 3.4A | 48x24x64 | 1217x610x1613 |



Shown as a stand alone counter-top unit with plastic feet.



Shown as a tiered shelving unit.



Shown with heated shelf, enclosure kit and standard Super Erecta shelving.



A simple way to keep hot tickets hot.

Metro2Go Hot Stations — {15.02}

Keep food hot, organized & ready-to-go.

Keep up with high volume carryout demand with Metro2Go Hot Stations.

Perfect for:

- Prepaid self service carryout orders
- Takeout or delivery order staging
- Grab & Go applications.

Entice customers, reduce labor costs, or simply improve speed & efficiency with Metro2Go Hot Stations... the affordable, efficient solution to keep food hot and ready-to-go.



Low Wattage Design:

All models operate on a single 15 Amp circuit

Easy-to-Clean:

Enclosures are removable for easy cleaning without tools. Microban antimicrobial product protection is built into the high touchpoint door handles to protect from bacteria growth and keep the handles "cleaner between cleanings".

Warranty:

2-year parts & labor warranty

Consistent Heat Distribution:

Metro2Go Hot Stations are constructed with Super Erecta Hot shelving. High quality, Type 304 stainless steel construction with aluminum inner core for consistent, reliable radiant heat across each shelf. Adjustable thermostat, 200°F (93°C) maximum surface

Power Cord:

Each shelf has a permanently mounted 6' (183cm) long cord with NEMA 5-15P plug end. 4 outlet cord management power strip with NEMA 5-15P plug end for single cord connection. temperature. Shelves are UL and NSF listed.



Individual shelves are UL & NSF listed.

The perfect fit for any operation.



Prepaid self-service takeout & delivery order staging.

Grab & Go



PU8CD-HS1842
(8) 6.7" high compartments perfect for pizza boxes.



PU4CD-HS1842
(4) 14.7" high compartments for bags, boxes & more.



GG2CD-HS1842
2-shelf Grab & Go station with doors for added security and longer holding.



GG2C-HS1842
2-shelf open Grab & Go station for easier customer access.

Metro2Go Hot Stations — {15.02}

| Model No. and Description | Dimensions | | Compartment Dimensions | | Electrical Specs |
|---|--------------------|------------------|------------------------|------------------|--------------------------|
| | W x D x H (in.) | W x D x H (mm) | W x D x H (in.) | W x D x H (mm) | |
| PU8CD-HS1842 Pizza 2Go Order Hot Station, 8 Compartments | 42.7 x 20.9 x 36.9 | 1085 x 531 x 938 | 8 19.0 x 18.0 x 6.7 | 482 x 457 x 179 | 120V, 1600W, 13.4A, NEMA |
| PU4CD-HS1842 2Go Order Hot Station, 4 Compartments | 42.7 x 20.9 x 36.9 | 1085 x 531 x 938 | 4 19.0 x 18.0 x 14.7 | 482 x 457 x 373 | 120V, 800W, 6.7A, NEMA |
| GG2CD-HS1842 Grab & Go Hot Station, 2 Shelves with Doors | 42.7 x 20.9 x 36.9 | 1085 x 531 x 938 | 2 39.5 x 18.0 x 14.7 | 1003 x 457 x 373 | 120V, 800W, 6.7A, NEMA |
| GG2C-HS1842 Open Grab & Go Hot Station, 2 Shelves | 42.7 x 20.4 x 36.9 | 1085 x 519 x 938 | 2 39.5 x 18.0 x 14.7 | 1003 x 457 x 373 | 120V, 800W, 6.7A, NEMA |

Note: Overall depth with optional rear doors is 21.7" (552mm)

Accessories

Super Erecta Hot & Metro2Go Hot Stations



HS-THERMCOVER
Optional thermostat cover to prevent set point change



HS-REARDOORS
Optional rear hinged doors shown on GG2CD-1842HS



HS-PSTRIP4
4 Outlet Power Strip: (120V, 15A, 1800W)

Freestanding Leg Kits

Allow you to convert from counter-top to freestanding with area for storage underneath



HS-1842LEGKIT-3F
Optional free standing leg kit with roll-under storage. Shown with PU8CD-HS1842.



HS-1842LEGKIT-S
Optional free standing leg kit with one storage shelf. Shown with PU8CD-HS1842.

MightyLite™

Insulated Food Carriers



LEARN MORE

MIGHTYLITE™ FRONT-LOAD PAN CARRIERS

60% Lighter
than traditionally molded carriers

Carries easy.

Ergonomic 8-handle design

Ultra light with 8 convenient handles, the ultimate design for lifting, carrying, and moving in any situation. MightyLite makes moving hot & cold food a lot easier!



ML300

ML400



Roll with it.



MightyLite dolly— Heavy-duty, 350 lbs. (158kg) capacity dolly to help transport carriers. Also designed to move milk crates.

Dolly safely nests on top of the carrier for secure vehicle transport.

Part # ML800HC-CART

This bundle includes one red ML400 Front-load Pan Carrier with MLH1 Heater for holding hot foods and one blue ML400-BU Front-load Pan Carrier for cold items.



Keeps Food
HotCold

5+ hrs.

Holds safe.

Safe & appetizing food every time

Load them up with food and confidently hold safe for hours. Standard size ML300 holds up to (4) full size pans, larger ML400 holds up to (6).

Lasts long.

Advanced polymer foam construction – EPP (Expanded Polypropylene)

The unbelievable strength-to-weight ratio and ability to absorb impact make MightyLite carriers perfect for lifting and withstanding the rigors of off-site food transport!



- Lightweight
- Super Strong
- Insulative
- Cleanable
- Recyclable

Stacks Securely: Features allow for secure stacking during transport or storage.

Mighty Door: Full-swing door for easy loading, durable travel latch, “gasketless” door seal, and large label holder/white board.



| | 12" x 20" – GN 1/1 Pan Capacity | | | Food Capacity (approx.) |
|-------|---------------------------------|------------|------------|-------------------------|
| | 2.5" / 65mm | 4" / 100mm | 6" / 150mm | |
| ML300 | 4 | 3 | 2 | 45 qts (42.4 L) |
| ML400 | 6 | 4 | 3 | 60 qts (56.8 L) |

ML300 & ML400 will also hold 1/3, 1/2, 2/3, fractional sized hotel / GN pans.

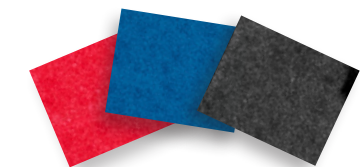

Available Lid & Door Colors

| | RED | BLUE | BLACK | Description | Dimensions (W x D x H) | | Product Weight | Approx. Pkd. Wt. |
|-------|----------|----------|-------|--------------------|------------------------|-----------------|--------------------|--------------------|
| | | | | | (in) | (mm) | | |
| ML300 | ML300-BU | ML300-BL | | 4 Pan Front Loader | 17.25 x 27 x 19.75 | 438 x 686 x 502 | 9.1 lbs. (4.1 kg) | 13.0 lbs. (5.9 kg) |
| ML400 | ML400-BU | ML400-BL | | 6 Pan Front Loader | 17.25 x 27 x 25.75 | 438 x 686 x 654 | 11.3 lbs. (5.1 kg) | 15.0 lbs. (6.8 kg) |



ML180XL ▶ **80% Lighter** than traditional top-loaders

ML180 ▶ **60% Lighter** than coolers

Stacks well with others.

The multi-purpose carrier.

Mightylite top-loaders handle more than just pans and stack well with Mightylite front-loaders. The multi-functional XL lid increases storage capacity and gives you the option to use it as an insulated server.

Stop worrying about temperature loss from frequent openings.

Temperature Retention Graph:

| Time / Action | With Heater (°F) | No Heater (°F) |
|-------------------|------------------|----------------|
| Start | 162 | 158 |
| After 1st opening | 160 | 157 |
| After 2nd opening | 159 | 152 |
| After 3rd opening | 158 | 151 |
| After 4th opening | 156 | 149 |

MLH1 (120V) Heater
MLHX1 (240V)* Heater

PAN REMOVED

| RED | BLUE | BLACK | Description | Dimensions (W x D x H) | | Product Weight | Approx. Pkd. Wt. |
|---------|------------|------------|---------------------|------------------------|-----------------|-------------------|-------------------|
| ML180 | ML180-BU | ML180-BL | Flat Lid Top-Loader | (in) | (mm) | | |
| ML180 | ML180-BU | ML180-BL | Flat Lid Top-Loader | 26.63 x 15.75 x 11.38 | 677 x 400 x 289 | 3.8 lbs. (1.7 kg) | 5.8 lbs. (2.6 kg) |
| ML180XL | ML180XL-BU | ML180XL-BL | XL Top-Loader | 26.63 x 15.75 x 16.13 | 677 x 400 x 410 | 4.6 lbs. (2.1 kg) | 7.4 lbs. (3.4 kg) |

The multi-purpose carrier with **63% more** storage.

TOP-LOADER **COOLER** **SERVER**

Supersized. 180XL

CAPACITY GUIDE

| | Inside Dimensions (W x D x H) | | 12" x 20" – GN 1/1 Pan Capacity | | | | Food Capacity (approx.) | Inside Capacity (approx.) | Covered Plates* | Container Sizes** | | | | | | | |
|---------|-------------------------------|-----------------|---------------------------------|----|----|----|-------------------------|---------------------------|-----------------|-------------------|------------|---------------|---------------|------------|-------------|--------|--|
| | (in) | (mm) | 2.5" | 4" | 6" | 8" | | | | Cans 12oz. | Cans 16oz. | Bottles 12oz. | Bottles 750ml | Bottles 2L | Half Gallon | Gallon | |
| ML180 | 21.0 x 12.9 x 8.1 | 533 x 327 x 205 | 3 | 2 | 1 | 1 | 30 qts (28.4 L) | 38 qts (36.0 L) | 6 | 40 | 40 | 36 | 14 | 8 | 10 | 4 | |
| ML180XL | 21.0 x 12.9 x 13.2 | 533 x 327 x 335 | 5 | 3 | 2 | 1 | 45 qts (42.4 L) | 62 qts (58.7 L) | 8 | 80 | 56 | 43 | 24 | 14 | 15 | 6 | |

*10.5" cover diameter and 2.75" covered plate height
**Container capacity may vary depending on individual container size.

Serve it up with a serving ring and top-loader.

Endless serving possibilities. **Transport and serve with a single solution** that does not require water or canned fuel.

MLD1 Dolly (Includes strap)

MLP1 Thermal Partition

MLC1 Wire Caddy (Included with front-loaders)

MLS1 Carrying Strap

MLH1 (120V) Heater
MLHX1 (240V)* Heater

MLW1 Serving Ring

Available Lid & Door Colors

* Not eligible for Quick Ship.



**Innovation
you can
touch.**



THERMAL CABINETS & RACKS



**CABINET
SELECTION GUIDE**

- Thermal Cabinets & Racks 178-233**
- C5® Cabinet Line & Accessories 180-211
- Heavy-Duty Heated Transport Cabinets 212-217
- Heavy-Duty Mobile Refrigerators 218-221
- Heated Banquet Cabinets & Accessories 222-228
- Holding/Delivery/Storage Cabinets 229
- Mobile Bun and Tray Racks 230-233



One Touch Menu Presets
Ensure repeatability & take the guess work out of temperature & humidity settings.

Simple, intuitive controls improve food quality & operational efficiency.

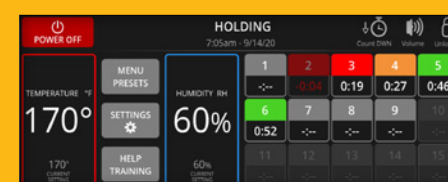

Programmable Timers
Manage first-in-first-out (FIFO) and holding times.

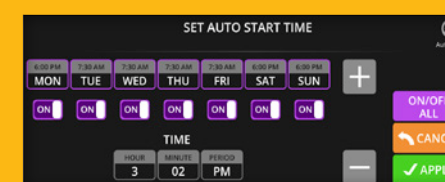

Auto-start Feature
Get your cabinet automatically running daily.

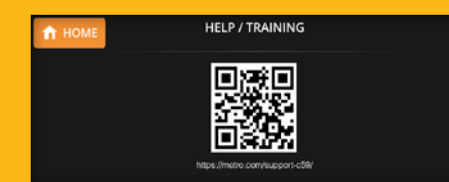

Other Efficiency Features
Help/Training, alarms, HACCP data logging, and more.



C5 9 Series

Simple touch, precise control for that oven-fresh taste.

Controlled Humidity Holding & Proofing Cabinets

Maintain that just made taste for hours with uniform control of temperature & actual relative humidity.

Precise simple-touch control, high-density fiberglass insulation and our unique airflow design ensures uniform holding from top to bottom, resulting in the best possible food quality.

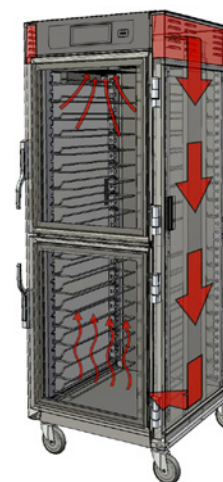

Heavily Insulated Stainless Steel Construction
2.5" thick, high density fiberglass insulation with Type 304 stainless steel construction.

Consistent Performance
High performance airflow design delivers uniform temperature & humidity throughout the cabinet by channeling hot air to the bottom of the cabinet and over the humidity pan, allowing it to rise naturally without blowing air directly over the food.

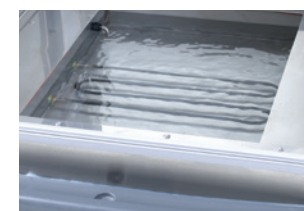

4 Gallon Reservoir
Maximize and control actual relative humidity levels inside the cabinet.

Universal Slides



Lip Load Slides



Slide Options
Two systems to choose from that hold a variety of pan sizes. Universal option for maximum pan flexibility or lip load to maximize 18x26 sheet pan capacity.



Available Sizes

Cabinets are 30" (762mm) wide, 36.375" (924mm) deep.

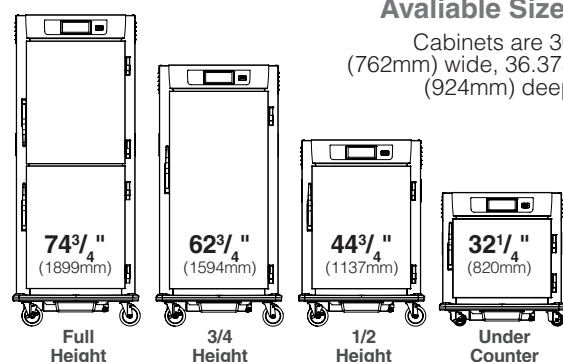

Full, 3/4, and 1/2 height stainless steel reach-in models with solid doors
32 models to choose from.

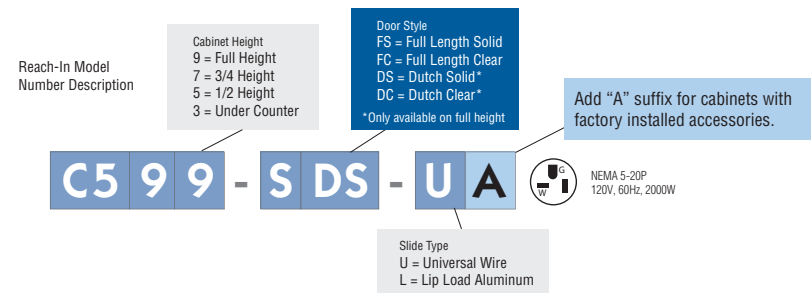

Add "L" or "X" for alternate electrical configurations (no upcharge)

C599L-SDS-U  NEMA 5-15P
120V, 60Hz, 1440W

C599X-SDS-U  NEMA 6-15P
220-240V, 50/60Hz, 1681-2000W

9 SERIES — {13.99}

Reach-In Cabinets

| Doors | Slides | Cat. No. Stainless Steel | Approx. Pkd. Wt. (lbs.) |
|--------------------|-----------|--------------------------|-------------------------|
| Full Height | | | |
| Full Solid | Universal | C599-SFS-U* | 400 |
| Full Solid | Lip Load | C599-SFS-L* | 390 |
| Dutch Solid | Universal | C599-SDS-U* | 410 |
| Dutch Solid | Lip Load | C599-SDS-L* | 400 |
| Full Clear | Universal | C599-SFC-U | 410 |
| Full Clear | Lip Load | C599-SFC-L | 400 |
| Dutch Clear | Universal | C599-SDC-U | 410 |
| Dutch Clear | Lip Load | C599-SDC-L | 400 |
| 3/4 Height | | | |
| Full Solid | Universal | C597-SFS-U* | 310 |
| Full Solid | Lip Load | C597-SFS-L* | 300 |
| Full Clear | Universal | C597-SFC-U | 307 |
| Full Clear | Lip Load | C597-SFC-L | 297 |

*120V 2000W and 1440W models with and without accessories are ENERGY STAR.

| Doors | Slides | Cat. No. Stainless Steel | Approx. Pkd. Wt. (lbs.) |
|---|-----------|--------------------------|-------------------------|
| 1/2 Height | | | |
| Full Solid | Universal | C595-SFS-U* | 200 |
| Full Solid | Lip Load | C595-SFS-L* | 190 |
| Full Clear | Universal | C595-SFC-U | 197 |
| Full Clear | Lip Load | C595-SFC-L | 187 |
| Under Counter (Not available in 120V, 2000W) | | | |
| Full Solid | Universal | C593L-SFS-U | 105 |
| Full Solid | Lip Load | C593L-SFS-L | 95 |
| Full Clear | Universal | C593L-SFC-U | 100 |
| Full Clear | Lip Load | C593L-SFC-L | 90 |

*120V 2000W and 1440W models with and without accessories are ENERGY STAR.

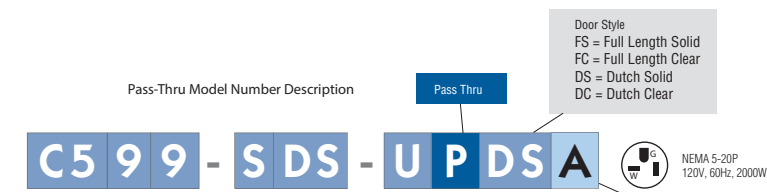

Add "L" or "X" for alternate electrical configurations (no upcharge)

C599L-SDS-UPDS  NEMA 5-15P
120V, 60Hz, 1440W

C599X-SDS-UPDS  NEMA 6-15P
220-240V, 50/60Hz, 1681-2000W

Pass-Thru Cabinets (Only available in Full Height or 1/2 Height)

| Doors/Rear Doors | Slides | Cat. No. Stainless Steel | Approx. Pkd. Wt. (lbs.) |
|------------------------------|-----------|--------------------------|-------------------------|
| Full Height Pass-Thru | | | |
| Full Solid/Full Solid | Universal | C599-SFS-UPFS | 435 |
| Full Solid/Full Clear | Universal | C599-SFS-UPFC | 430 |
| Full Solid/Full Solid | Lip Load | C599-SFS-LPFS | 390 |
| Full Solid/Full Clear | Lip Load | C599-SFS-LPFC | 435 |
| Dutch Solid/Dutch Solid | Universal | C599-SDS-UPDS | 410 |
| Dutch Solid/Dutch Clear | Universal | C599-SDS-UPDC | 435 |
| Dutch Solid/Dutch Solid | Lip Load | C599-SDS-LPDS | 400 |
| Dutch Solid/Dutch Clear | Lip Load | C599-SDS-LPDC | 430 |
| Full Clear/Full Clear | Universal | C599-SFC-UPFC | 400 |
| Full Clear/Full Solid | Universal | C599-SFC-UPFS | 435 |
| Full Clear/Full Clear | Lip Load | C599-SFC-LPFC | 400 |
| Full Clear/Full Solid | Lip Load | C599-SFC-LPFS | 430 |
| Dutch Clear/Dutch Clear | Universal | C599-SDC-UPDC | 410 |
| Dutch Clear/Dutch Solid | Universal | C599-SDC-UPDS | 435 |
| Dutch Clear/Dutch Clear | Lip Load | C599-SDC-LPDC | 400 |
| Dutch Clear/Dutch Solid | Lip Load | C599-SDC-LPDS | 430 |
| 1/2 Height Pass-Thru | | | |
| Full Solid/Full Solid | Universal | C595-SFS-UPFS | 210 |
| Full Solid/Full Clear | Universal | C595-SFS-UPFC | 218 |
| Full Solid/Full Solid | Lip Load | C595-SFS-LPFS | 200 |
| Full Solid/Full Clear | Lip Load | C595-SFS-LPFC | 205 |
| Full Clear/Full Clear | Universal | C595-SFC-UPFC | 207 |
| Full Clear/Full Solid | Universal | C595-SFC-UPFS | 218 |
| Full Clear/Full Clear | Lip Load | C595-SFC-LPFC | 200 |
| Full Clear/Full Solid | Lip Load | C595-SFC-LPFS | 205 |

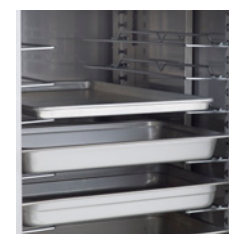

Universal Slides



Lip Load Slides

| Cabinet Size | Universal Wire Pan Capacity | | | | | | Lip Load Pan Capacity | | |
|-------------------|-----------------------------|------|------------|--------------|------------|------------|-----------------------|-----|--------------------|
| | Slide Pairs | | Sheet Pans | Steam Pans | | | Gastronorm 65mm Depth | | Sheet Pans 18"x26" |
| | Provided | Max* | 18"x26" | 12"x20"x2.5" | 12"x20"x4" | 12"x20"x6" | 2/1 | 1/1 | |
| Full Height | 18 | 36 | 18 | 34 | 24 | 14 | 17 | 34 | 35 |
| Full Height Dutch | 18 | 35 | 17 | 32 | 22 | 12 | 16 | 32 | 34 |
| 3/4 Height | 14 | 28 | 13 | 26 | 16 | 12 | 13 | 26 | 27 |
| 1/2 Height | 9 | 17 | 8 | 16 | 10 | 6 | 8 | 16 | 17 |
| Under Counter | 5 | 9 | 5 | 10 | 6 | 4 | 5 | 10 | 10 |

*Maximum number of slide pairs @ 1.5" spacing. Additional slide pairs ordered separately.



One Touch Menu Presets

Ensure repeatability & take the guess work out of temperature settings.



Simple, intuitive controls improve food quality & operational efficiency.

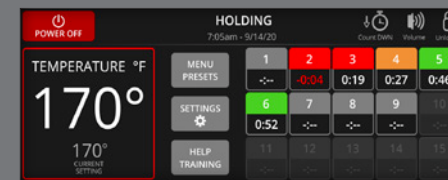

Programmable Timers

Manage first-in-first-out (FIFO) and holding times.

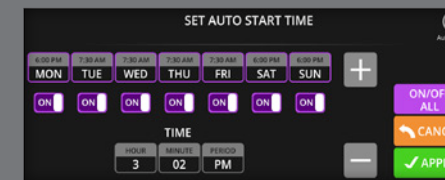

Auto-start Feature

Get your cabinet automatically running daily.

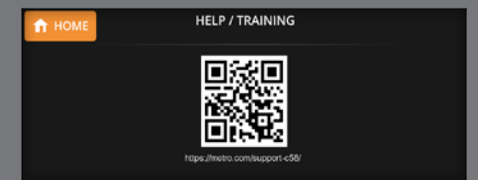

Other Efficiency Features

Help/Training, alarms, HACCP data logging, and more.



LEARN MORE

C5 8 Series

Simple touch, precise temperature control for that oven-fresh taste.

Precision Controlled Heated Holding Cabinets.

Maintain that just made taste for hours with simple touch uniform control of temperature.

Precise temperature control, passive humidity, high-density fiberglass insulation and our unique air-flow design ensures uniform holding from top to bottom resulting in the best possible food quality.

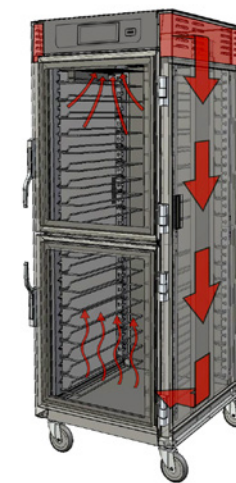

Heavily Insulated Stainless Steel Construction

2.5" thick, high density fiberglass insulation with Type 304 stainless steel construction.

Consistent Performance

High performance airflow design delivers uniform temperature throughout the cabinet by channeling hot air to the bottom of the cabinet and over the passive humidity pan, allowing it to rise naturally without blowing air directly over the food.



Passive Humidity

Integrated water pan allows hot air to flow over water to create humidity.

Universal Slides



Lip Load Slides



Slide Options

Two systems to choose from that hold a variety of pan sizes. Universal option for maximum pan flexibility or lip load to maximize 18x26 sheet pan capacity.

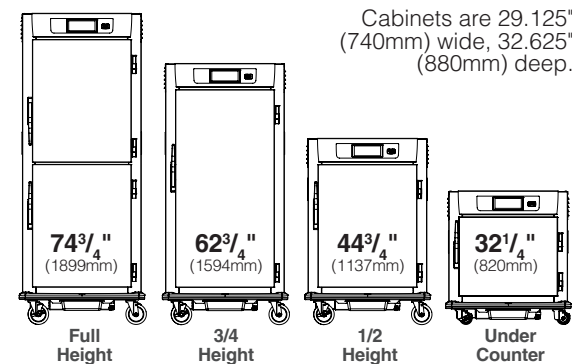

Full, 3/4, and 1/2 height stainless steel reach-in models with solid doors 32 models to choose from.

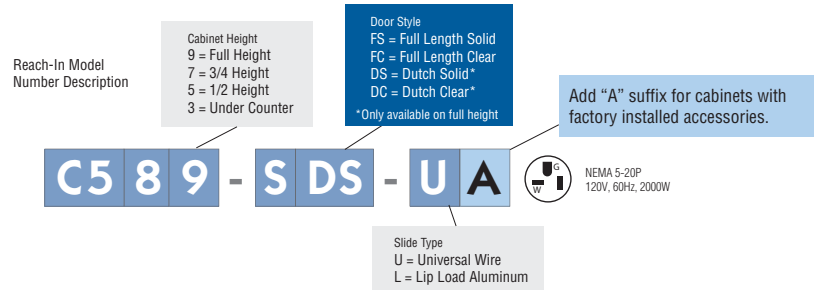

Add "L" or "X" for alternate electrical configurations (no upcharge)

C589L-SDS-U  NEMA 5-15P 120V, 60Hz, 1440W

C589X-SDS-U  NEMA 6-15P 220-240V, 50/60Hz, 1681-2000W

8 SERIES — {13.98}

Reach-In Cabinets

| Doors | Slides | Cat. No. Stainless Steel | Approx. Pkd. Wt. (lbs.) |
|--------------------|-----------|--------------------------|-------------------------|
| Full Height | | | |
| Full Solid | Universal | C589-SFS-U* | 375 |
| Full Solid | Lip Load | C589-SFS-L* | 3650 |
| Dutch Solid | Universal | C589-SDS-U* | 385 |
| Dutch Solid | Lip Load | C589-SDS-L* | 375 |
| Full Clear | Universal | C589-SFC-U | 415 |
| Full Clear | Lip Load | C589-SFC-L | 415 |
| Dutch Clear | Universal | C589-SDC-U | 415 |
| Dutch Clear | Lip Load | C589-SDC-L | 415 |
| 3/4 Height | | | |
| Full Solid | Universal | C587-SFS-U* | 285 |
| Full Solid | Lip Load | C587-SFS-L* | 307 |
| Full Clear | Universal | C587-SFC-U | 307 |
| Full Clear | Lip Load | C587-SFC-L | 280 |

*120V 2000W and 1440W models with and without accessories are ENERGY STAR.

| Doors | Slides | Cat. No. Stainless Steel | Approx. Pkd. Wt. (lbs.) |
|---|-----------|--------------------------|-------------------------|
| 1/2 Height | | | |
| Full Solid | Universal | C585-SFS-U* | 175 |
| Full Solid | Lip Load | C585-SFS-L* | 175 |
| Full Clear | Universal | C585-SFC-U | 205 |
| Full Clear | Lip Load | C585-SFC-L | 205 |
| Under Counter (Not available in 120V, 2000W) | | | |
| Full Solid | Universal | C583L-SFS-U | 80 |
| Full Solid | Lip Load | C583L-SFS-L | 70 |
| Full Clear | Universal | C583L-SFC-U | 105 |
| Full Clear | Lip Load | C583L-SFC-L | 100 |

*120V 2000W and 1440W models with and without accessories are ENERGY STAR.

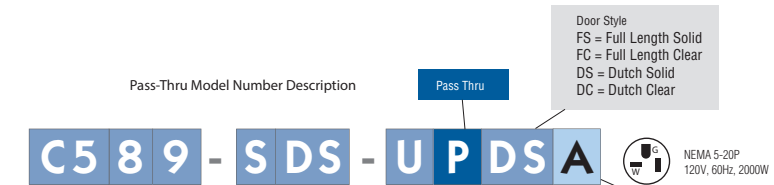

Add "L" or "X" for alternate electrical configurations (no upcharge)

C589L-SDS-UPDS  NEMA 5-15P 120V, 60Hz, 1440W

C589X-SDS-UPDS  NEMA 6-15P 220-240V, 50/60Hz, 1681-2000W

Add "A" suffix for cabinets with factory installed accessories.



Pass-Thru Cabinets (Only available in Full Height or 1/2 Height)

| Doors/Rear Doors | Slides | Cat. No. Stainless Steel | Approx. Pkd. Wt. (lbs.) |
|------------------------------|-----------|--------------------------|-------------------------|
| Full Height Pass-Thru | | | |
| Full Solid/Full Solid | Universal | C589-SFS-UPFS | 375 |
| Full Solid/Full Clear | Universal | C589-SFS-UPFC | 435 |
| Full Solid/Full Solid | Lip Load | C589-SFS-LPFS | 385 |
| Full Solid/Full Clear | Lip Load | C589-SFS-LPFC | 435 |
| Dutch Solid/Dutch Solid | Universal | C589-SDS-UPDS | 380 |
| Dutch Solid/Dutch Clear | Universal | C589-SDS-UPDC | 430 |
| Dutch Solid/Dutch Solid | Lip Load | C589-SDS-LPDS | 390 |
| Dutch Solid/Dutch Clear | Lip Load | C589-SDS-LPDC | 430 |
| Full Clear/Full Clear | Universal | C589-SFC-UPFC | 400 |
| Full Clear/Full Solid | Universal | C589-SFC-UPFS | 435 |
| Full Clear/Full Clear | Lip Load | C589-SFC-LPFC | 390 |
| Full Clear/Full Solid | Lip Load | C589-SFC-LPFS | 435 |
| Dutch Clear/Dutch Clear | Universal | C589-SDC-UPDC | 410 |
| Dutch Clear/Dutch Solid | Universal | C589-SDC-UPDS | 435 |
| Dutch Clear/Dutch Clear | Lip Load | C589-SDC-LPDC | 400 |
| Dutch Clear/Dutch Solid | Lip Load | C589-SDC-LPDS | 435 |
| 1/2 Height Pass-Thru | | | |
| Full Solid/Full Solid | Universal | C585-SFS-UPFS | 170 |
| Full Solid/Full Clear | Universal | C585-SFS-UPFC | 218 |
| Full Solid/Full Solid | Lip Load | C585-SFS-LPFS | 165 |
| Full Solid/Full Clear | Lip Load | C585-SFS-LPFC | 210 |
| Full Clear/Full Clear | Universal | C585-SFC-UPFC | 218 |
| Full Clear/Full Solid | Universal | C585-SFC-UPFS | 218 |
| Full Clear/Full Clear | Lip Load | C585-SFC-LPFC | 210 |
| Full Clear/Full Solid | Lip Load | C585-SFC-LPFS | 210 |



Universal Slides

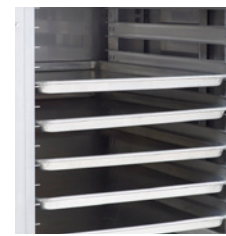

Lip Load Slides

| Cabinet Size | Universal Wire Pan Capacity | | | | | | Lip Load Pan Capacity | |
|-------------------|-----------------------------|------|------------|--------------|------------|------------|-----------------------|-----|
| | Slide Pairs | | Sheet Pans | Steam Pans | | | Gastronorm 65mm Depth | |
| | Provided | Max* | 18"x26" | 12"x20"x2.5" | 12"x20"x4" | 12"x20"x6" | 2/1 | 1/1 |
| Full Height | 18 | 36 | 18 | 34 | 24 | 14 | 17 | 34 |
| Full Height Dutch | 18 | 35 | 17 | 32 | 22 | 12 | 16 | 32 |
| 3/4 Height | 14 | 28 | 13 | 26 | 16 | 12 | 13 | 26 |
| 1/2 Height | 9 | 17 | 8 | 16 | 10 | 6 | 8 | 16 |
| Under Counter | 5 | 9 | 5 | 10 | 6 | 4 | 5 | 10 |

*Maximum number of slide pairs @ 1.5" spacing. Additional slide pairs ordered separately.



LEARN MORE



C5 6 Series

High performance insulated cabinets with traditional temperature control.

Designed to maintain food temperature and quality by continuously monitoring and controlling internal cabinet temperature. 6 Series cabinets give you professional results.

Available Sizes

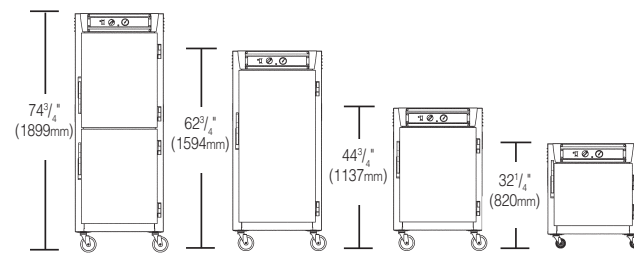

All cabinets are 29.125" (740mm) wide and 32.625" (829mm) deep (Pass-thru are 34.625" (880mm) deep).



Full and 3/4 height reach-in models with solid doors and all 1/2 height reach-in models.

36 models to choose from.

Temperature

The easy-to-use dial puts you in control of cabinet

Reliable Readout

Measures and displays actual cabinet temperature even when the cabinet is off.



Traditional Top-Mounted Controls

Electro-mechanical thermostat and "always-on" analog thermometer for continuous monitoring of cabinet temperature, even when turned off or unplugged.

Ergonomic, user-friendly controls are mounted at the top of the cabinet for improved access, to help prevent damage, and easy cleaning.

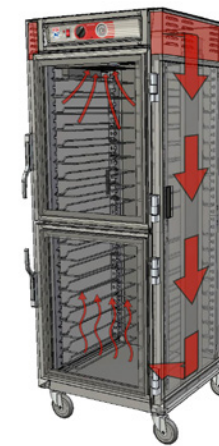

Heavily Insulated Stainless Steel Construction

2.5" thick, high density fiberglass insulation with Type 304 stainless steel construction.

Consistent Performance

High performance airflow design delivers uniform temperature throughout the cabinet by channeling hot air to the bottom of the cabinet and over the passive humidity pan, allowing it to rise naturally without blowing air directly over the food.

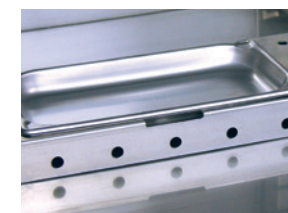

Passive Humidity

Integrated water pan allows hot air to flow over water to create humidity.

Universal Slides



Lip Load Slides



Slide Options

Two systems to choose from that hold a variety of pan sizes. Universal option for maximum pan flexibility or lip load to maximize 18x26 sheet pan capacity.



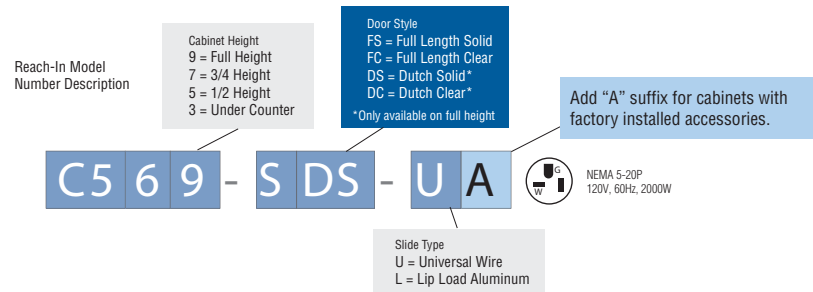

Doors

Field reversible, solid or glass insulated doors with high strength magnetic pull latch for easy access.



Add "L" or "X" for alternate electrical configurations (no upcharge)

C569L-SDS-U  NEMA 5-15P
120V, 60Hz, 1440W

C569X-SDS-U  NEMA 6-15P
220-240V, 50/60Hz, 1681-2000W

6 SERIES — {13.96}

Reach-In Cabinets

| Doors | Slides | Cat. No. Stainless Steel | Approx. Pkd. Wt. (lbs.) |
|--------------------|-----------|--------------------------|-------------------------|
| Full Height | | | |
| Full Solid | Universal | C569-SFS-U* | 375 |
| Full Solid | Lip Load | C569-SFS-L* | 365 |
| Dutch Solid | Universal | C569-SDS-U* | 385 |
| Dutch Solid | Lip Load | C569-SDS-L* | 375 |
| Full Clear | Universal | C569-SFC-U | 415 |
| Full Clear | Lip Load | C569-SFC-L | 415 |
| Dutch Clear | Universal | C569-SDC-U | 415 |
| Dutch Clear | Lip Load | C569-SDC-L | 415 |
| 3/4 Height | | | |
| Full Solid | Universal | C567-SFS-U* | 285 |
| Full Solid | Lip Load | C567-SFS-L* | 307 |
| Full Clear | Universal | C567-SFC-U | 307 |
| Full Clear | Lip Load | C567-SFC-L | 280 |

*120V 2000W and 1440W models with and without accessories are ENERGY STAR.

| Doors | Slides | Cat. No. Stainless Steel | Approx. Pkd. Wt. (lbs.) |
|---|-----------|--------------------------|-------------------------|
| 1/2 Height | | | |
| Full Solid | Universal | C565-SFS-U* | 175 |
| Full Solid | Lip Load | C565-SFS-L* | 175 |
| Full Clear | Universal | C565-SFC-U* | 205 |
| Full Clear | Lip Load | C565-SFC-L* | 205 |
| Under Counter (Not available in 120V, 2000W) | | | |
| Full Solid | Universal | C563L-SFS-U | 80 |
| Full Solid | Lip Load | C563L-SFS-L | 70 |
| Full Clear | Universal | C563L-SFC-U | 105 |
| Full Clear | Lip Load | C563L-SFC-L | 100 |

*120V 2000W and 1440W models with and without accessories are ENERGY STAR.

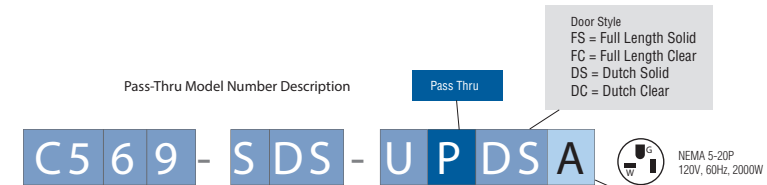

Add "L" or "X" for alternate electrical configurations (no upcharge)

Add "A" suffix for cabinets with factory installed accessories.

C569L-SDS-UPDS  NEMA 5-15P
120V, 60Hz, 1440W

C569X-SDS-UPDS  NEMA 6-15P
220-240V, 50/60Hz, 1681-2000W

Pass-Thru Cabinets (Only available in Full Height or 1/2 Height)

| Doors/Rear Doors | Slides | Cat. No. Stainless Steel | Approx. Pkd. Wt. (lbs.) |
|------------------------------|-----------|--------------------------|-------------------------|
| Full Height Pass-Thru | | | |
| Full Solid/Full Solid | Universal | C569-SFS-UPFS | 375 |
| Full Solid/Full Clear | Universal | C569-SFS-UPFC | 435 |
| Full Solid/Full Solid | Lip Load | C569-SFS-LPFS | 385 |
| Full Solid/Full Clear | Lip Load | C569-SFS-LPFC | 435 |
| Dutch Solid/Dutch Solid | Universal | C569-SDS-UPDS | 380 |
| Dutch Solid/Dutch Clear | Universal | C569-SDS-UPDC | 430 |
| Dutch Solid/Dutch Solid | Lip Load | C569-SDS-LPDS | 390 |
| Dutch Solid/Dutch Clear | Lip Load | C569-SDS-LPDC | 430 |
| Full Clear/Full Clear | Universal | C569-SFC-UPFC | 400 |
| Full Clear/Full Solid | Universal | C569-SFC-UPFS | 435 |
| Full Clear/Full Clear | Lip Load | C569-SFC-LPFC | 3900 |
| Full Clear/Full Solid | Lip Load | C569-SFC-LPFS | 435 |
| Dutch Clear/Dutch Clear | Universal | C569-SDC-UPDC | 410 |
| Dutch Clear/Dutch Solid | Universal | C569-SDC-UPDS | 435 |
| Dutch Clear/Dutch Clear | Lip Load | C569-SDC-LPDC | 400 |
| Dutch Clear/Dutch Solid | Lip Load | C569-SDC-LPDS | 435 |
| 1/2 Height Pass-Thru | | | |
| Full Solid/Full Solid | Universal | C565-SFS-UPFS | 170 |
| Full Solid/Full Clear | Universal | C565-SFS-UPFC | 218 |
| Full Solid/Full Solid | Lip Load | C565-SFS-LPFS | 165 |
| Full Solid/Full Clear | Lip Load | C565-SFS-LPFC | 210 |
| Full Clear/Full Clear | Universal | C565-SFC-UPFC | 218 |
| Full Clear/Full Solid | Universal | C565-SFC-UPFS | 218 |
| Full Clear/Full Clear | Lip Load | C565-SFC-LPFC | 210 |
| Full Clear/Full Solid | Lip Load | C565-SFC-LPFS | 210 |



Universal Slides

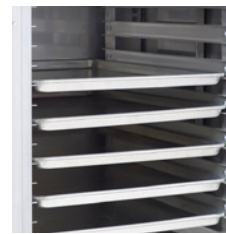

Lip Load Slides

| Cabinet Size | Universal Wire Pan Capacity | | | | | | Lip Load Pan Capacity | | |
|-------------------|-----------------------------|------|------------|--------------|------------|------------|-----------------------|-----|------------|
| | Slide Pairs | | Sheet Pans | Steam Pans | | | Gastronorm 65mm Depth | | Sheet Pans |
| | Provided | Max* | 18"x26" | 12"x20"x2.5" | 12"x20"x4" | 12"x20"x6" | 2/1 | 1/1 | 18"x26" |
| Full Height | 18 | 36 | 18 | 34 | 24 | 14 | 17 | 34 | 35 |
| Full Height Dutch | 18 | 35 | 17 | 32 | 22 | 12 | 16 | 32 | 34 |
| 3/4 Height | 14 | 28 | 13 | 26 | 16 | 12 | 13 | 26 | 27 |
| 1/2 Height | 9 | 17 | 8 | 16 | 10 | 6 | 8 | 16 | 17 |
| Under Counter | 5 | 9 | 5 | 10 | 6 | 4 | 5 | 10 | 10 |

*Maximum number of slide pairs @ 1.5" spacing. Additional slide pairs ordered separately.



C5 9, 8, 6 SERIES ACCESSORIES

Rear Push Handle

Stainless steel tubular handle mounted on rearside of the cabinet for mobile applications.

| Description | Cat. No. |
|------------------|------------|
| Rear Push Handle | C5-HANDLE* |

*Not available on pass-thru models



CONTROL PANEL COVER

Locking cover protects settings but allows cabinet to be turned on and off.

| Description | Cat. No. |
|---------------------|----------|
| Control Panel Cover | C5-COVER |

Note: Only available on the C5 6 Series.

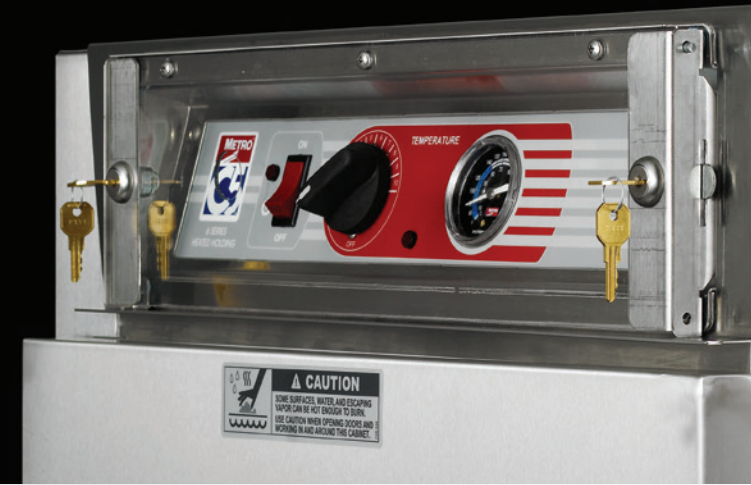

Bumper Options

| Description | Cat. No. |
|------------------------------------|-------------|
| Full Perimeter Bumper | C5-PERMBUMP |
| Polymer Corner Bumper/Drip Trough* | C5-BUMPDRIP |

*Note: Standard feature on 9 Series cabinets

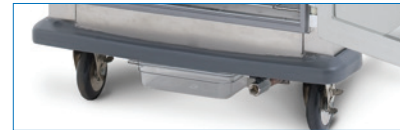

Polymer Corner Bumper



Full Perimeter Bumper

Door, Plug & Caster Options

| Description | Cat. No. |
|---|----------------|
| Travel Latch / Hasp | C59-TRVL |
| Flush Door Latch* | C5-LATCHFLUSH |
| Key Locking Door Latch (not available on under counter models)* | C5-LATCHLOCK |
| Whiteboard / Clipboard Information Panel*** | C5-INFOPNL |
| Factory Left-Hand Door Hinging | DD3768 |
| Factory Same-Side Pass-thru Door Hinging | C5-SAMESIDE |
| Straight Plug (20 Amp, 120V) — in lieu of standard** | C5-STRPLG-20 |
| Straight Plug (15 Amp, 120V) — in lieu of standard** | C5-STRPLG-15 |
| Twist Lock Plug (20 Amp, 120V) — in lieu of standard** | C5-RTWSTPLG |
| Twist Lock Plug (15 Amp, 120V) — in lieu of standard** | C5-RTWSTPLG-15 |
| 5" Rear Rigid Casters (pair) — in lieu of standard | C5-5RDGCSTR |
| 6" Casters (set of 4 swivel) — in lieu of standard | C5-6CASTER |
| 6" Stainless Steel Legs (set of 4) — in lieu of casters | C5-SSLEGS |

*Note: Order (1) per door (ie — dutch, pass-thru models require 4 each).

**Note: 9,8,6 Series 120V units come standard with right angle plug, straight plug standard on 220-240V units.

***Note: Only available on solid doors.



Travel Latch



Standard

Flush

Key Locking

Slide & Shelf Options

| Description | Cat. No. |
|--|-----------------|
| Extra Universal Slide Pair (2 pieces) Chrome | C5-USLIDPR-C |
| Extra Universal Slide Pair (2 pieces) Stainless Steel | C5-USLIDPR-S |
| Full Height Stainless Steel Universal Slide Upgrade* | C5-USLIDE-9S |
| 3/4 Height Stainless Steel Universal Slide Upgrade* | C5-USLIDE-7S |
| 1/2 Height Stainless Steel Universal Slide Upgrade* | C5-USLIDE-5S |
| Under Counter Stainless Steel Universal Slide Upgrade* | C5-USLIDE-3S |
| Small Item Shelf** | C5-SHELF-S |
| (4) Wire Shelves in Lieu of Universal Slides (full height models)* | C5-SHELFONLY-9S |
| (3) Wire Shelves in Lieu of Universal Slides (3/4 height models)* | C5-SHELFONLY-7S |
| (2) Wire Shelves in Lieu of Universal Slides (1/2 height models)* | C5-SHELFONLY-5S |
| (2) Wire Shelves in Lieu of Universal Slides (under counter models)* | C5-SHELFONLY-3S |

*Note: Must order universal slide model ("U")

**Note: Can only be used with universal slides ("U"). Does not work with lip-load slides



Small Item Shelf

RECOMMENDED C5 9 SERIES FOOD SETTINGS



| PRODUCT | TEMPERATURE F (°C) | RELATIVE HUMIDITY %* | PRODUCT | TEMPERATURE F (°C) | RELATIVE HUMIDITY %* |
|----------------------------------|-----------------------|-------------------------|------------------------------|-----------------------|-------------------------|
| MEATS | | | VEGETABLES | | |
| Prime Rib | 175 (79) | 75 | Broccoli, Spears | 175 (79) | 70 |
| Hamburgers | 180 (82) | 60 | Carrots, Sliced, Crinkled | 175 (79) | 70 |
| Hot Dogs | 170 (77) | 70 | Cauliflower, Clusters IQF | 175 (79) | 70 |
| Roast Beef | 175 (79) | 65 | Corn on the Cob | 180 (82) | 75 |
| Roast Pork | 175 (79) | 65 | Mixed Vegetables | 175 (79) | 70 |
| Ribs (Pork Spareribs) | 175 (79) | 70 | STARCHES | | |
| FISH | | | Fry, Regular 3/8" | 195 (91) | OFF ² |
| Fish, Baked (Cod Loin) IQF | 170 (77) | 45 | Potatoes, Mashed | 175 (79) | 70 |
| Fish, Batter Dipped | 175 (79) | 30 | Potatoes, Baked | 180 (82) | 65 |
| POULTRY | | | Potatoes, Scalloped | 175 (79) | 75 |
| Chicken, Boneless, Skinless | 175 (79) | 70 | Pasta, Elbow Macaroni | 180 (82) | 55 |
| Chicken, Thigh, Baked, Fried | 175 (79) | 70 | Rice | 180 (82) | 75 |
| Chicken, Full Breast | 175 (79) | 70 | Lasagna, Meat Sauce & Cheese | 185 (85) | 70 |
| Chicken, Drum, Baked, Fried | 175 (79) | 55 | Beans | 175 (79) | 65 |
| Chicken, Leg | 175 (79) | 70 | BREADS | | |
| Chicken, Fried Full Breast | 175 (79) | 45 | Biscuit, Buttermilk Mini | 175 (79) | OFF ¹ |
| Chicken, Fried Thigh | 175 (79) | 45 | Croissants, Sliced | 155 (68) | OFF ¹ |
| Chicken, Fried Drum | 175 (79) | 45 | French Toast, Thin Slice | 175 (79) | OFF ¹ |
| Chicken, Fried Boneless Skinless | 175 (79) | 45 | Waffles, Original | 175 (79) | OFF ¹ |
| Chicken, Whole Roasted | 170 (77) | 65 | Pancakes | 175 (79) | OFF ² |
| Turkey | 175 (79) | 70 | Pizza | 175 (79) | OFF ² |
| | | | Rolls | 175 (79) | OFF ¹ |
| | | | Dough (Proofing) | 90 - 100 (32 - 38) | 80 - 90 |

Developed in conjunction with the Center for Food Innovation (CFI), Penn State University
Temperature settings remain the same for non-humidity controlled cabinets.

(1) Water Reservoir **FULL**
(2) Water Reservoir **EMPTY**

* NOTE: Recommended Humidity Set point. Readout will display relative humidity inside the cabinet based on actual conditions and may vary from set point based on door opening, quantity and temperature of food, and moisture content of food. Use feedback to vary settings as required for individual products and desired results.

** NOTE: When Relative Humidity is set to OFF the cabinet will not generate additional humidity but will continue to display the actual relative humidity inside the cabinet. To reduce humidity further, increase the temperature setting and/or drain the water reservoir.



LEARN MORE

Performance & Value



All models with solid doors are ENERGY STAR



C5 4 Series with Insulation Armour® Plus

High performance holding and energy efficiency at a lower initial investment.

Metro's innovative hybrid polymer/stainless steel design exceeds traditional double wall fiberglass cabinet construction by replacing the costly exterior layer of sheet metal with foamed-in-place polyurethane insulated polymer panels. Performance and value at the "4-front" of innovation, Insulation Armour® Plus provides superior energy efficiency, built-in vertical handles, and full body bumper protection at the right price!

Dimensions

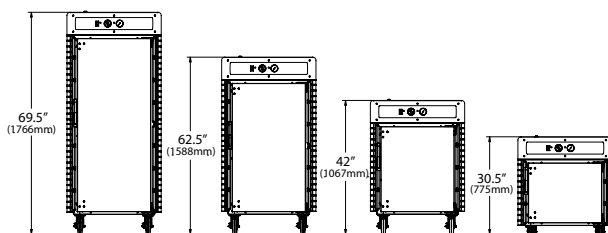

All cabinets are 30" (762mm) wide and 33" (838mm) deep

Innovative Design.

Superior Energy Efficiency

Polymer panels with foamed-in-place polyurethane insulation retain heat and save energy.



Top-Mounted Controls

Ergonomic, user-friendly controls are mounted at the top of the cabinet for improved access, to help prevent damage, and easy cleaning.

Consistent Airflow

High performance airflow design gently circulates hot air for improved temperature consistency. Air is channeled to the bottom of the cabinet, then rises naturally without blowing directly over the food.

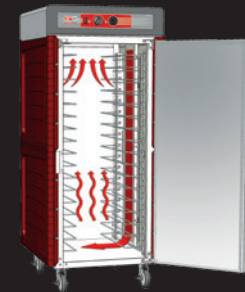

Armour Panels

Panels have molded-in handles and act as a full-body bumper for improved handling and protection in mobile applications.

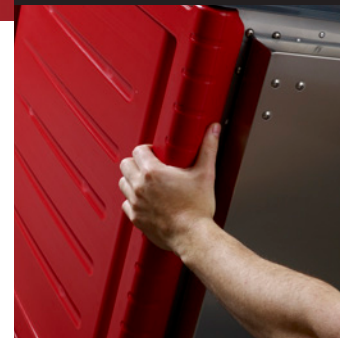

Slides

Two systems to choose from that hold a variety of pan sizes. Universal option for maximum pan flexibility or lip load to maximize 18x26 sheet pan capacity.



Heavy-Duty Door & Hinges

Field reversible stainless steel door with 2" thick high-density fiberglass insulation and 11-gauge stainless steel hinges.



Stainless Steel Construction

High-quality Type 304 stainless steel for easy cleaning and long-term durability.





Universal Slides



Lip Load Slides

| Cabinet Size | Universal Wire Pan Capacity | | | | | | Lip Load Pan Capacity | |
|-------------------|-----------------------------|------|------------|--------------|------------|------------|-----------------------|-----|
| | Slide Pairs | | Sheet Pans | Steam Pans | | | Gastronorm 65mm Depth | |
| | Provided | Max* | 18"x26" | 12"x20"x2.5" | 12"x20"x4" | 12"x20"x6" | 2/1 | 1/1 |
| Full Height | 17 | 34 | 17 | 34 | 22 | 14 | 17 | 34 |
| Full Height Dutch | 16 | 32 | 16 | 32 | 20 | 12 | 16 | 32 |
| 5/6 Height | 14 | 29 | 14 | 28 | 20 | 12 | 14 | 29 |
| 1/2 Height | 8 | 15 | 8 | 16 | 10 | 6 | 8 | 16 |
| Under Counter | 5 | 10 | 5 | 10 | 6 | 4 | 5 | 10 |

*Maximum number of slide pairs @ 1.5" spacing. Additional slide pairs ordered separately.

Model Number Description

Cabinet Height
9 = Full Height
8 = 5/6 Height
5 = 1/2 Height
3 = Under Counter

Door Style
FS = Full Length Solid
FC = Full Length Clear
DS = Dutch Solid*
DC = Dutch Clear*
*Only available on full height

Add "A" suffix for cabinets with factory installed accessories.

Slide Type
U = Universal Wire
L = Lip Load Aluminum

Electrical Configuration: NEMA 5-15P 120V, 60Hz, 1400W

Example Model Number: **C549-ASFS-UA**

Add "X" for alternate electrical configurations (no upcharge)

Example Model Number: **C549X-ASFS-U** (NEMA 6-15P 220-240V, 50/60Hz, 1176-1400W)

4 SERIES — {13.94}

WITH INSULATION
ARMOUR® PLUS

| Electrical | Doors | Slides | Cat No. | Approx. Pkd. Wt. (lbs.) |
|----------------------|-------------|-----------|---------------------|-------------------------|
| Full Height | | | | |
| 120V, 60 Hz | Full Solid | Universal | C549-ASFS-U* | 345 |
| 120V, 60 Hz | Full Solid | Lip Load | C549-ASFS-L* | 325 |
| 120V, 60 Hz | Dutch Solid | Universal | C549-ASDS-U* | 345 |
| 120V, 60 Hz | Dutch Solid | Lip Load | C549-ASDS-L* | 325 |
| 120V, 60 Hz | Dutch Clear | Universal | C549-ASDC-U | 351 |
| 120V, 60 Hz | Dutch Clear | Lip Load | C549-ASDC-L | 331 |
| 220-240V, 50/60Hz | Full Solid | Universal | C549X-ASFS-U | 345 |
| 220-240V, 50/60Hz | Dutch Solid | Universal | C549X-ASDS-U | 345 |
| 220-240V, 50/60Hz | Dutch Clear | Universal | C549X-ASDC-U | 351 |
| 5/6 Height | | | | |
| 120V, 60 Hz | Full Solid | Universal | C548-ASFS-U* | 305 |
| 120V, 60 Hz | Full Solid | Lip Load | C548-ASFS-L* | 287 |
| 220-240V, 50/60Hz | Full Solid | Universal | C548X-ASFS-U | 305 |
| 1/2 Height | | | | |
| 120V, 60 Hz | Full Solid | Universal | C545-ASFS-U* | 260 |
| 120V, 60 Hz | Full Solid | Lip Load | C545-ASFS-L* | 245 |
| 220-240V, 50/60Hz | Full Solid | Universal | C545X-ASFS-U | 260 |
| Under Counter | | | | |
| 120V, 60 Hz | Full Solid | Universal | C543-ASFS-U* | 212 |
| 120V, 60 Hz | Full Solid | Lip Load | C543-ASFS-L* | 204 |
| 120V, 60 Hz | Full Clear | Universal | C543-ASFC-U | 215 |
| 120V, 60 Hz | Full Clear | Lip Load | C543-ASFC-L | 207 |
| 220-240V, 50/60Hz | Full Solid | Universal | C543X-ASFS-U | 212 |
| 220-240V, 50/60Hz | Full Clear | Universal | C543X-ASFC-U | 215 |

*120V solid door models with and without accessories are ENERGY STAR.

ACCESSORIES

Door, Plug & Caster Options

| Description | Cat. No. |
|---|-----------------------|
| Travel Latch/Hasp* | C54-TRVL |
| Factory Left-Hand Door Hinging | DD3768 |
| Straight Plug (15 Amp, 120V) — in lieu of standard** | C5-STRPLG-15 |
| Twist Lock Plug (15 Amp, 120V) — in lieu of standard** | C5-RTWSTPLG-15 |
| 5" Rear Rigid Casters (pair) — in lieu of standard | C5-5RDGCSTR |
| 6" Casters (set of 4 swivel) — in lieu of standard | C5-6CASTER |
| 6" Stainless Steel Legs (set of 4) — in lieu of casters | C5-SSLEGS |

*Note: C54-TRVL is only available on full, 5/6, 1/2 height solid doors (not available on clear doors or under counter cabinets).
**Note: 120V units come standard with right angle plug, straight plug standard on 220-240V units.

Slide & Shelf Options

| Description | Cat. No. |
|--|------------------------|
| Extra Universal Slide Pair (2 pieces) Chrome | C5-USLIDEPR-C |
| Extra Universal Slide Pair (2 pieces) Stainless Steel | C5-USLIDEPR-S |
| Full Height Stainless Steel Universal Slide Upgrade* | C5-USLIDE-9S |
| 5/6 Height Stainless Steel Universal Slide Upgrade* | C5-USLIDE-7S |
| 1/2 Height Stainless Steel Universal Slide Upgrade* | C5-USLIDE-5S |
| Under Counter Stainless Steel Universal Slide Upgrade* | C5-USLIDE-3S |
| Small Item Shelf** | C5-SHELF-S |
| (4) Wire Shelves in Lieu of Universal Slides (full height models)* | C5-SHELFONLY-9S |
| (3) Wire Shelves in Lieu of Universal Slides (5/6 height models)* | C5-SHELFONLY-7S |
| (2) Wire Shelves in Lieu of Universal Slides (1/2 height models)* | C5-SHELFONLY-5S |
| (2) Wire Shelves in Lieu of Universal Slides (under counter models)* | C5-SHELFONLY-3S |

*Note: Must order universal slide model ("U")
**Note: Can only be used with universal slides ("U"). Does not work with lip-load slides



C54-TRVL



Stainless steel leg option available for counter top applications.



Small Item Shelf



Model Number Description

C5 4 9 N - S U A

Cabinet Height
9 = Full Height
8 = 5/6 Height
5 = 1/2 Height

Add "A" suffix for cabinets with factory installed accessories.

Slide Type
U = Universal Wire
L = Lip Load Aluminum

| Size | Slides | Approx. Pkd. Wt. (lbs.) | Cat No. |
|------------|-----------|-------------------------|-----------------|
| Full | Universal | 309 | C549N-SU |
| Full | Lip Load | 284 | C549N-SL |
| 5/6 Height | Universal | 275 | C548N-SU |
| 5/6 Height | Lip Load | 257 | C548N-SL |
| 1/2 Height | Universal | 230 | C545N-SU |
| 1/2 Height | Lip Load | 215 | C545N-SL |

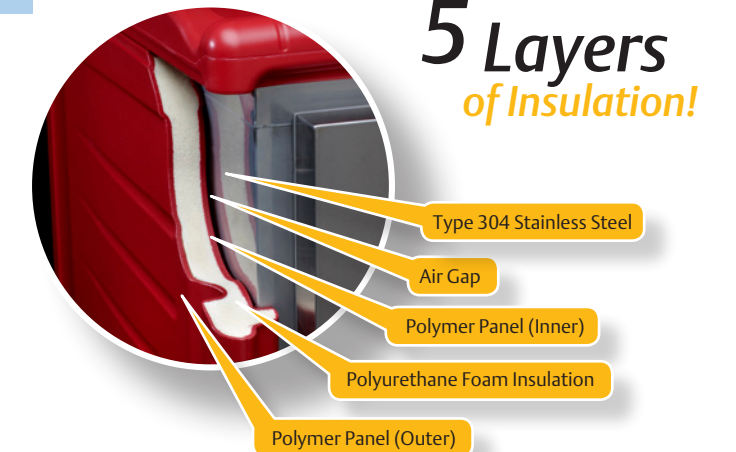

5 Layers of Insulation!

Holds UP TO 60% MORE
12X20 / GN PANS PER SQ FT

HOLD MORE, SAVE SPACE, REDUCE LABOR

FITS BOTH
12X20 / GN PANS & 18X26 PANS

FLEXIBILITY TO HOLD MORE YOUR WAY

C5 4 Series with Insulation Armour® Plus

Hot or cold insulated food transport. Performance and value in every square inch.

Metro's innovative hybrid polymer/stainless steel design exceeds common polymer insulated transport cart construction in a variety of ways: Foamed-in-place insulation helps to safely hold food hot for 5 hours or cold for 3 hours, high-quality stainless steel makes for easy cleaning and long-term durability, and greater pan capacity will save space and help reduce food transport expenditures.

Dimensions

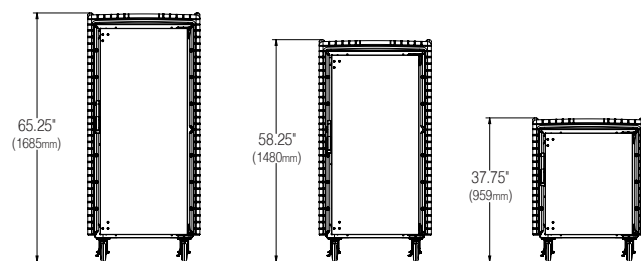

All cabinets are 30" (762mm) wide and 33" (838mm) deep

ACCESSORIES

Door, Plug & Caster Options

| Description | Cat. No. |
|--|--------------------|
| Travel Latch / Hasp | C54-TRVL |
| Factory Left-Hand Door Hinging | DD3768 |
| 5" Rear Rigid Casters (pair) — in lieu of standard | C5-5RDGCSTR |
| 6" Casters (set of 4 swivel) — in lieu of standard | C5-6CASTER |

Slide & Shelf Options

| Description | Cat. No. |
|--|------------------------|
| Extra Universal Slide Pair (2 pieces) Chrome | C5-USLIDEPR-C |
| Extra Universal Slide Pair (2 pieces) Stainless Steel | C5-USLIDEPR-S |
| Full Height Stainless Steel Universal Slide Upgrade* | C5-USLIDE-9S |
| 5/6 Height Stainless Steel Universal Slide Upgrade* | C5-USLIDE-7S |
| 1/2 Height Stainless Steel Universal Slide Upgrade* | C5-USLIDE-5S |
| Small Item Shelf** | C5-SHELF-S |
| (4) Wire Shelves in Lieu of Universal Slides (full height models)* | C5-SHELFONLY-9S |
| (3) Wire Shelves in Lieu of Universal Slides (5/6 height models)* | C5-SHELFONLY-7S |
| (2) Wire Shelves in Lieu of Universal Slides (1/2 height models)* | C5-SHELFONLY-5S |

*Note: Must order universal slide model ("U")

**Note: Can only be used with universal slides ("U"). Does not work with lip-load slides





LEARN MORE

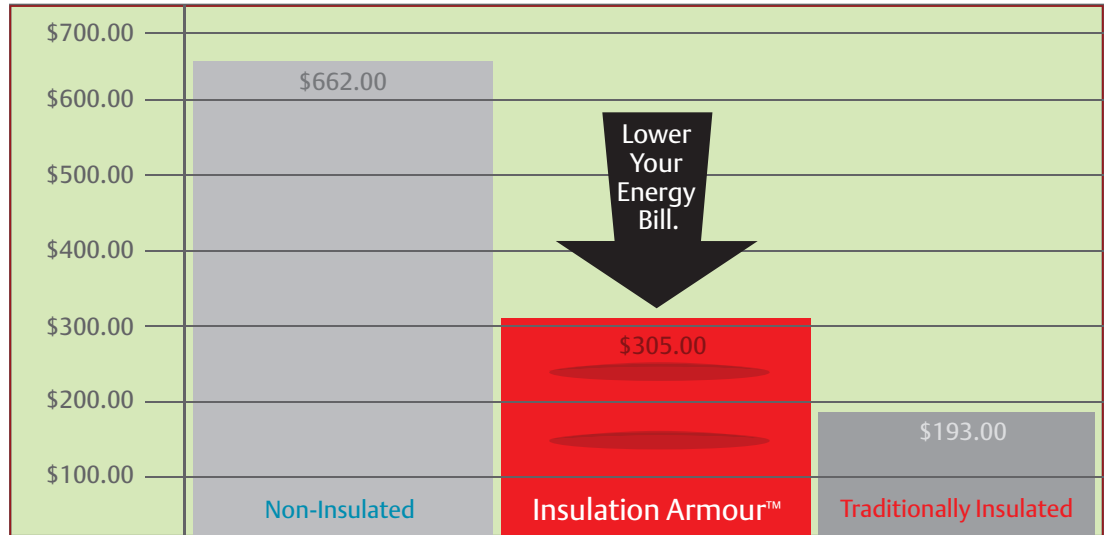

*Average annual energy cost based on \$.12 KWH electricity rate, 12 hours of daily use, 365 days a year. Energy cost and savings will vary depending on usage, electricity cost, and comparative model.



C5 3 Series with Insulation Armour®

Cool-to-touch design provides energy efficiency at a lower initial investment.

Insulation Armour insulates the cabinet and protects employees from hot surfaces. Built-in hand holds and full-body bumper protection make it easy to handle when used in mobile applications.

Available Sizes

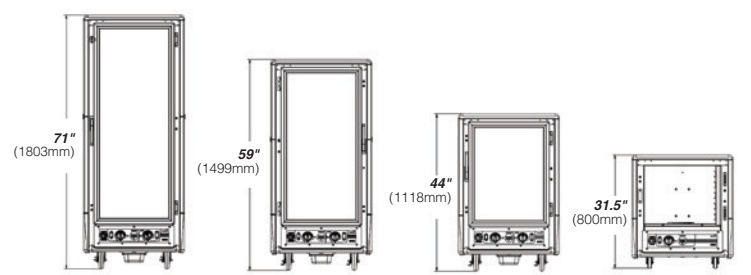

All cabinets are 27.63" (702mm) wide and 31.5" (800mm) deep (aluminum construction).



Colors
Insulation Armour is available in red, blue, or gray.



Unique Design

Cool-to-touch design provides energy efficiency at a lower initial investment. Patented technology retains heat and saves energy!

Removable Control Module
Entire module is removable without tools for easy cleaning and servicing. Three modules to choose from: holding, moisture holding, and combination proofing and holding.

Slides
Three systems to choose from that hold a variety of pan sizes: universal, lip load, fixed wire.

Doors
Field reversible, solid insulated or clear polycarbonate doors. Full-height cabinets available with full length or dutch doors.



Insulation Armour®

Durable polymer exterior insulates the cabinet and is dent, impact, and stain resistant. Molded-in hand holds create vertical handles for mobile applications.





3 SERIES CONTROL MODULES

THE OPTIONS YOU NEED TO KEEP YOU IN COMPLETE CONTROL

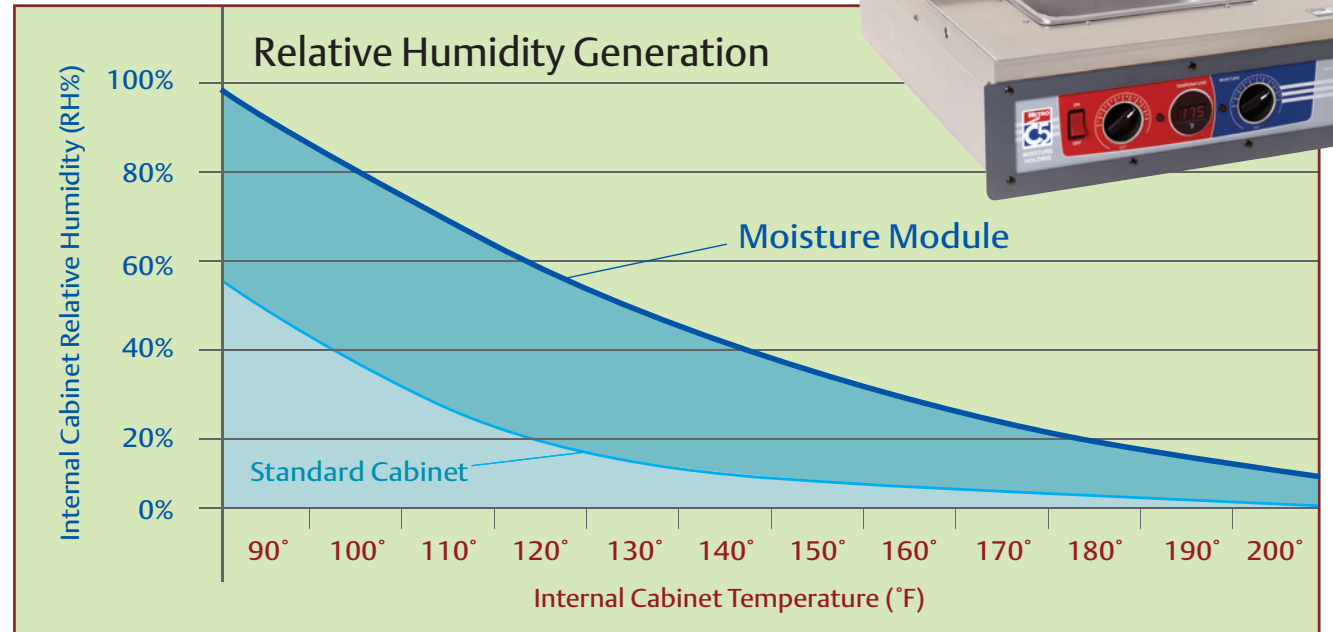

HOLDING MODULE

Heated holding only.



Electrical Configurations

- NEMA 5-20P
120V, 60Hz, 2000W
- NEMA 5-15P
120V, 60Hz, 1440W
- NEMA 6-15P
220-240V, 50/60Hz, 1681-2000W

MOISTURE MODULE

Heated holding with moisture control and proofing capabilities.



Electrical Configurations

- NEMA 5-20P
120V, 60Hz, 2000W
- NEMA 6-15P
220-240V, 50/60Hz, 1681-2000W

COMBINATION MODULE

Heated holding and proofing capabilities.



Electrical Configurations

- NEMA 5-20P
120V, 60Hz, 2000W
- NEMA 5-15P
120V, 60Hz, 1440W
- NEMA 6-15P
220-240V, 50/60Hz, 1681-2000W



The most important consideration when choosing a heated holding cabinet is the food. Many foods, in particular proteins, hold best in a moist environment. The Moisture Module option for the C5 3 Series delivers 5 times the moisture-generating power of a standard “dry” cabinet at a price far below that of conventional high-humidity alternatives. Metro delivers the ability to assure food safety and improve food quality in a “game changing” design. The Moisture Module inside an Insulation Armour cabinet is a one-of-a-kind product, and an unbelievable value!



3 SERIES — {13.93}
WITH INSULATION
ARMOUR®

Model Number Description

Cabinet Height
9 = Full Height
7 = 3/4 Height
5 = 1/2 Height
3 = Undercounter

Door Style
FS = Full Length Solid
FC = Full Length Clear
DS = Dutch Solid*
DC = Dutch Clear*
*Only available on full height

Add "A" suffix for cabinets with factory installed accessories.

Module Type
H = Heated Holding
C = Combination
M = Moisture

Slide Type
U = Universal Wire
L = Lip Load Aluminum
4 = Fixed Wire*
*Not Available in Undercounter

C539 - CDS - UA

NEMA 5-20P
120V, 60Hz, 2000W
(Holding, Combination, Moisture)

Add "L" or "X" for alternate electrical configurations (no upcharge)

C539-CLDS-U NEMA 5-15P
120V, 60Hz, 1440W
(Holding, Combination)

C539-CXDS-U NEMA 6-15P
220-240V, 50/60Hz, 1681-2000W
(Holding, Combination, Moisture)

Holding Module Cabinets

| Doors | Slides | Approx. Pkd. Wt. (lbs.) | Cat No. |
|--------------------|------------|-------------------------|-------------------|
| FULL HEIGHT | | | |
| Full Clear | Fixed Wire | 248 | C539-HFC-4 |
| Full Clear | Universal | 262 | C539-HFC-U |
| Full Clear | Lip Load | 257 | C539-HFC-L |
| Full Solid | Fixed Wire | 268 | C539-HFS-4 |
| Full Solid | Universal | 282 | C539-HFS-U |
| Full Solid | Lip Load | 277 | C539-HFS-L |
| Dutch Clear | Fixed Wire | 250 | C539-HDC-4 |
| Dutch Clear | Universal | 264 | C539-HDC-U |
| Dutch Clear | Lip Load | 259 | C539-HDC-L |
| Dutch Solid | Fixed Wire | 270 | C539-HDS-4 |
| Dutch Solid | Universal | 283 | C539-HDS-U |
| Dutch Solid | Lip Load | 278 | C539-HDS-L |

| Doors | Slides | Approx. Pkd. Wt. (lbs.) | Cat No. |
|--|------------|-------------------------|--------------------|
| 3/4 HEIGHT | | | |
| Full Clear | Fixed Wire | 173 | C537-HFC-4 |
| Full Clear | Universal | 144 | C537-HFC-U |
| Full Clear | Lip Load | 178 | C537-HFC-L |
| Full Solid | Fixed Wire | 173 | C537-HFS-4 |
| Full Solid | Universal | 191 | C537-HFS-U |
| Full Solid | Lip Load | 186 | C537-HFS-L |
| 1/2 HEIGHT | | | |
| Full Clear | Fixed Wire | 173 | C535-HFC-4 |
| Full Clear | Universal | 144 | C535-HFC-U |
| Full Clear | Lip Load | 178 | C535-HFC-L |
| Full Solid | Fixed Wire | 173 | C535-HFS-4 |
| Full Solid | Universal | 191 | C535-HFS-U |
| Full Solid | Lip Load | 186 | C535-HFS-L |
| UNDERCOUNTER (Not available in 120V, 2000W) | | | |
| Full Clear | Fixed Wire | 113 | C533-HLFC-U |
| Full Clear | Lip Load | 113 | C533-HLFC-L |
| Full Solid | Fixed Wire | 114 | C533-HLFS-U |
| Full Solid | Lip Load | 114 | C533-HLFS-L |

3 Series cabinets ship with Red Insulation Armour, please add color designation if Blue (-BU) or Gray (-GY) is desired.
Note: Undercounter models only available in Red or Gray (-GY)
(ex. C539-CDS-U-BU or C539-CDS-U-BUA if with accessories)

Combination Module Cabinets

| Doors | Slides | Approx. Pkd. Wt. (lbs.) | Cat No. |
|--|------------|-------------------------|--------------------|
| FULL HEIGHT | | | |
| Full Clear | Fixed Wire | 248 | C539-CFC-4 |
| Full Clear | Universal | 262 | C539-CFC-U |
| Full Clear | Lip Load | 257 | C539-CFC-L |
| Full Solid | Fixed Wire | 268 | C539-CFS-4 |
| Full Solid | Universal | 282 | C539-CFS-U |
| Full Solid | Lip Load | 277 | C539-CFS-L |
| Dutch Clear | Fixed Wire | 250 | C539-CDC-4 |
| Dutch Clear | Universal | 264 | C539-CDC-U |
| Dutch Clear | Lip Load | 259 | C539-CDC-L |
| Dutch Solid | Fixed Wire | 270 | C539-CDS-4 |
| Dutch Solid | Universal | 283 | C539-CDS-U |
| Dutch Solid | Lip Load | 278 | C539-CDS-L |
| 3/4 HEIGHT | | | |
| Full Clear | Fixed Wire | 173 | C537-CFC-4 |
| Full Clear | Universal | 144 | C537-CFC-U |
| Full Clear | Lip Load | 178 | C537-CFC-L |
| Full Solid | Fixed Wire | 173 | C537-CFS-4 |
| Full Solid | Universal | 191 | C537-CFS-U |
| Full Solid | Lip Load | 186 | C537-CFS-L |
| 1/2 HEIGHT | | | |
| Full Clear | Fixed Wire | 173 | C535-CFC-4 |
| Full Clear | Universal | 144 | C535-CFC-U |
| Full Clear | Lip Load | 178 | C535-CFC-L |
| Full Solid | Fixed Wire | 173 | C535-CFS-4 |
| Full Solid | Universal | 191 | C535-CFS-U |
| Full Solid | Lip Load | 186 | C535-CFS-L |
| UNDERCOUNTER (Not available in 120V, 2000W) | | | |
| Full Clear | Fixed Wire | 113 | C533-CLFC-U |
| Full Clear | Lip Load | 113 | C533-CLFC-L |
| Full Solid | Fixed Wire | 114 | C533-CLFS-U |
| Full Solid | Lip Load | 114 | C533-CLFS-L |

Moisture Module Cabinets

| Doors | Slides | Approx. Pkd. Wt. (lbs.) | Cat No. |
|---------------------|------------|-------------------------|--------------------|
| FULL HEIGHT | | | |
| Full Clear | Fixed Wire | 248 | C539-MFC-4 |
| Full Clear | Universal | 262 | C539-MFC-U |
| Full Clear | Lip Load | 257 | C539-MFC-L |
| Full Solid | Fixed Wire | 268 | C539-MFS-4 |
| Full Solid | Universal | 282 | C539-MFS-U |
| Full Solid | Lip Load | 277 | C539-MFS-L |
| Dutch Clear | Fixed Wire | 250 | C539-MDC-4 |
| Dutch Clear | Universal | 264 | C539-MDC-U |
| Dutch Clear | Lip Load | 259 | C539-MDC-L |
| Dutch Solid | Fixed Wire | 270 | C539-MDS-4 |
| Dutch Solid | Universal | 283 | C539-MDS-U |
| Dutch Solid | Lip Load | 278 | C539-MDS-L |
| 3/4 HEIGHT | | | |
| Full Clear | Fixed Wire | 173 | C537-MFC-4 |
| Full Clear | Universal | 144 | C537-MFC-U |
| Full Clear | Lip Load | 178 | C537-MFC-L |
| Full Solid | Fixed Wire | 173 | C537-MFS-4 |
| Full Solid | Universal | 191 | C537-MFS-U |
| Full Solid | Lip Load | 186 | C537-MFS-L |
| 1/2 HEIGHT | | | |
| Full Clear | Fixed Wire | 173 | C535-MFC-4 |
| Full Clear | Universal | 144 | C535-MFC-U |
| Full Clear | Lip Load | 178 | C535-MFC-L |
| Full Solid | Fixed Wire | 173 | C535-MFS-4 |
| Full Solid | Universal | 191 | C535-MFS-U |
| Full Solid | Lip Load | 186 | C535-MFS-L |
| UNDERCOUNTER | | | |
| Full Clear | Fixed Wire | 113 | C533-MLFC-U |
| Full Clear | Lip Load | 113 | C533-MLFC-L |
| Full Solid | Fixed Wire | 114 | C533-MLFS-U |
| Full Solid | Lip Load | 114 | C533-MLFS-L |



| Cabinet Size | Universal Wire Pan Capacity | | | | | | Lip Load Pan Capacity | | Fixed Wire Pan Capacity | | | | |
|-------------------|-----------------------------|------|------------|--------------|------------|------------|-----------------------|-----|-------------------------|------------|--------------|-----------------------|-----|
| | Slide Pairs | | Sheet Pans | Steam Pans | | | Sheet Pans | | Sheet Pans | Sheet Pans | Steam Pans | Gastronorm 65mm Depth | |
| | Provided | Max* | 18"x26" | 12"x20"x2.5" | 12"x20"x4" | 12"x20"x6" | 2/1 | 1/1 | 18"x26" | 18"x26" | 12"x20"x2.5" | 2/1 | 1/1 |
| Full Height | 18 | 36 | 18 | 34 | 24 | 14 | 17 | 34 | 35 | 18 | 34 | 17 | 34 |
| Full Height Dutch | 18 | 35 | 17 | 32 | 22 | 12 | 16 | 32 | 34 | 17 | 32 | 16 | 32 |
| 3/4 Height | 14 | 28 | 14 | 26 | 16 | 10 | 13 | 26 | 27 | 14 | 26 | 13 | 26 |
| 1/2 Height | 9 | 17 | 8 | 16 | 10 | 6 | 8 | 16 | 17 | 8 | 16 | 8 | 16 |
| Undercounter | 5 | 10 | 5 | 10 | 6 | 4 | 5 | 10 | 10 | - | - | - | - |

*Maximum number of slide pairs @ 1.5" spacing. Additional slide pairs ordered separately.



3 Removable Control Modules to choose from.

Entire module is removable without tools for easy cleaning and servicing. Choose from: holding, proofing, or combination proofing and holding.



HOLDING MODULE: Heated holding only.



Electrical Configurations

NEMA 5-20P 120V, 60Hz, 2000W NEMA 6-15P 220-240V, 50/60Hz, 1681-2000W

PROOFING MODULE: Proofing only.



Electrical Configurations

NEMA 5-15P 120V, 60Hz, 1440W NEMA 6-15P 220-240V, 50/60Hz, 1210-1440W

COMBINATION MODULE: Heated holding & proofing.



Electrical Configurations

NEMA 5-20P 120V, 60Hz, 2000W NEMA 6-15P 220-240V, 50/60Hz, 1681-2000W



C5 1 Series

Non-insulated holding and proofing cabinets.

Reliable performance for proofing and basic holding needs.

Available Sizes

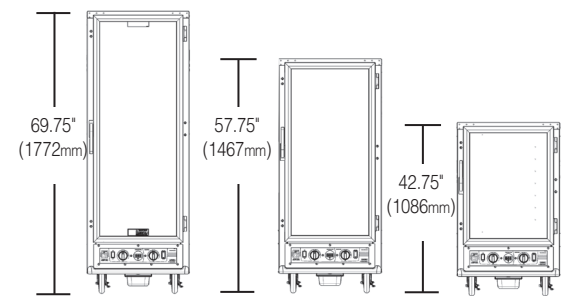

All cabinets are 25.13" (638mm) wide and 30.25" (768mm) deep



Universal Slides
Maximum flexibility to hold 12x20 steam, 18x26 sheet, and GN pans.



Lip Load Slides
Maximize 18x26 sheet pan capacity.



Fixed Wire
Spaced on 3" centers to hold 12x20x2.5 steam, 18x26 sheet, and GN pans (65mm deep).



Shelf Option
For covered plates or odd size pans and dishes.

Clear Door

Clear polycarbonate doors provide visibility of the contents inside the cabinet without the heat loss associated with opening the door.

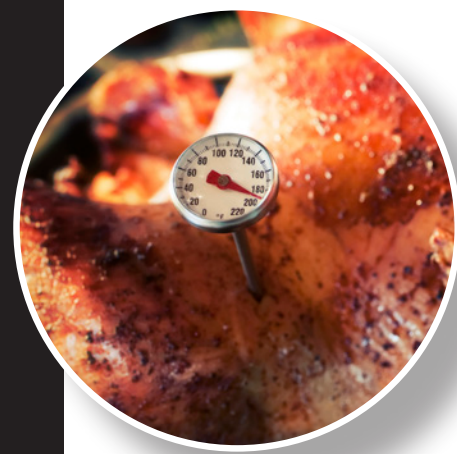

More Power for Food Safety

2000 watt power for increased performance and food safety in holding applications.





C5 3 & 1 SERIES ACCESSORIES



1 SERIES — {13.91}

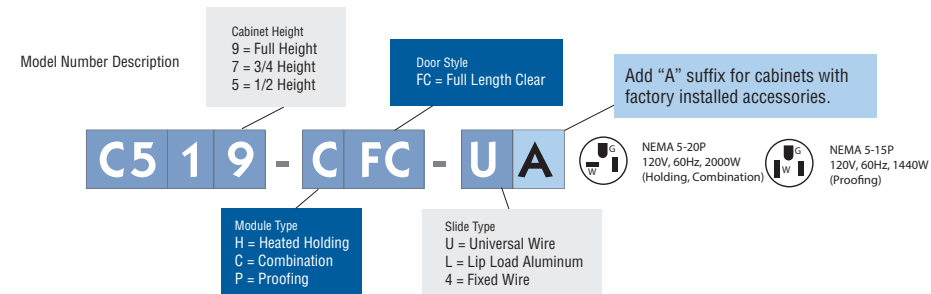

Add "X" for alternate electrical configurations (no upcharge)

C519-CXFC-U  NEMA 6-15P
220-240V, 50/60Hz, 1681-2000W (Holding, Combination)
220-240V, 50/60Hz, 1210-1440W (Proofing)

| Doors | Slides | Module | Cat. No. | Approx. Pkd. Wt. (lbs.) |
|--------------------|------------|-------------|------------|-------------------------|
| Full Height | | | | |
| Full Length Clear | Fixed Wire | Combination | C519-CFC-4 | 197 |
| Full Length Clear | Universal | Combination | C519-CFC-U | 211 |
| Full Length Clear | Lip Load | Combination | C519-CFC-L | 206 |
| Full Length Clear | Fixed Wire | Holding | C519-HFC-4 | 197 |
| Full Length Clear | Universal | Holding | C519-HFC-U | 211 |
| Full Length Clear | Lip Load | Holding | C519-HFC-L | 206 |
| Full Length Clear | Fixed Wire | Proofing | C519-PFC-4 | 197 |
| Full Length Clear | Universal | Proofing | C519-PFC-U | 211 |
| Full Length Clear | Lip Load | Proofing | C519-PFC-L | 206 |
| 3/4 Height | | | | |
| Full Length Clear | Fixed Wire | Combination | C517-CFC-4 | 130 |
| Full Length Clear | Universal | Combination | C517-CFC-U | 139.5 |
| Full Length Clear | Lip Load | Combination | C517-CFC-L | 135 |
| Full Length Clear | Fixed Wire | Holding | C517-HFC-4 | 130 |
| Full Length Clear | Universal | Holding | C517-HFC-U | 139.5 |
| Full Length Clear | Lip Load | Holding | C517-HFC-L | 130 |
| Full Length Clear | Fixed Wire | Proofing | C517-PFC-4 | 130 |
| Full Length Clear | Universal | Proofing | C517-PFC-U | 139.5 |
| Full Length Clear | Lip Load | Proofing | C517-PFC-L | 135 |
| 1/2 Height | | | | |
| Full Length Clear | Fixed Wire | Combination | C515-CFC-4 | 98 |
| Full Length Clear | Universal | Combination | C515-CFC-U | 104 |
| Full Length Clear | Lip Load | Combination | C515-CFC-L | 101 |
| Full Length Clear | Fixed Wire | Holding | C515-HFC-4 | 98 |
| Full Length Clear | Universal | Holding | C515-HFC-U | 104 |
| Full Length Clear | Lip Load | Holding | C515-HFC-L | 101 |
| Full Length Clear | Fixed Wire | Proofing | C515-PFC-4 | 104 |
| Full Length Clear | Universal | Proofing | C515-PFC-U | 98 |
| Full Length Clear | Lip Load | Proofing | C515-PFC-L | 101 |



Universal Slides



Lip Load Slides



Fixed Wire Slides

| Cabinet Size | Universal Wire Pan Capacity | | | | | | Lip Load Pan Capacity | | Fixed Wire Pan Capacity | | | | |
|--------------|-----------------------------|------------------|--------------------|------------|----|----|-----------------------|--------------------|-------------------------|-------------------------|---------------------------|---------------------------|----|
| | Slide Pairs Provided | Slide Pairs Max* | Sheet Pans 18"x26" | Steam Pans | | | Sheet Pans 18"x26" | Sheet Pans 18"x26" | Sheet Pans 18"x26" | Steam Pans 12"x20"x2.5" | Gastronorm 65mm Depth 2/1 | Gastronorm 65mm Depth 1/1 | |
| Full Height | 18 | 36 | 18 | 34 | 24 | 14 | 17 | 34 | 35 | 18 | 34 | 17 | 34 |
| 3/4 Height | 14 | 28 | 14 | 26 | 16 | 10 | 13 | 26 | 27 | 14 | 26 | 13 | 26 |
| 1/2 Height | 9 | 17 | 8 | 16 | 10 | 6 | 8 | 16 | 17 | 8 | 16 | 8 | 16 |

*Maximum number of slide pairs @ 1.5" spacing. Additional slide pairs ordered separately.

1 Series Rear Push Handle

Stainless steel tubular handle mounted to the back of the cabinet.

| Description | Cat. No. |
|-------------------|------------|
| Rear Push Handle* | C5-RHANDLE |

* Not available on 3 Series cabinets.



1 Series Rear Push Handle

Bumper Option

| Description | Cat. No. |
|-----------------------|---------------|
| Full Perimeter Bumper | C5-PERMBUMP-1 |

Note: 3 Series cabinets come standard with full body bumper



Polymer Corner Bumper

Door, Plug & Caster Options

| Description | Cat. No. |
|---|-----------------|
| Flush Door Latch* | C5-LATCHFLUSH-1 |
| Travel Latch | C5-TRVL |
| Factory Left Hand Door Hinging | DD3768 |
| Straight Plug (20 Amp, 120V) — in lieu of standard** | C5-STRPLG-20 |
| Straight Plug (15 Amp, 120V) — in lieu of standard** | C5-STRPLG-15 |
| 5" Rear Rigid Casters (pair) — in lieu of standard | C5-5RDGCSTR |
| 6" Casters (set of 4 swivel) — in lieu of standard | C5-6CASTER |
| 6" Stainless Steel Legs (set of 4) — in lieu of casters | C5-SSLEGS |

*Note: Order (1) per door (ie — dutch door models require 2 ea.)

**Note: 3,1 Series 120V units come standard with right angle plug, straight plug standard on 220-240V units



C5-LATCHFLUSH-1

Slide & Shelf Options

| Description | Cat. No. |
|--|-----------------|
| Extra Universal Slide Pair (2 pieces) Chrome | C5-USLIDEPR-C |
| Extra Universal Slide Pair (2 pieces) Stainless Steel | C5-USLIDEPR-S |
| Full Height Stainless Steel Universal Slide Upgrade* | C5-USLIDE-9S |
| 3/4 Height Stainless Steel Universal Slide Upgrade* | C5-USLIDE-7S |
| 1/2 Height Stainless Steel Universal Slide Upgrade* | C5-USLIDE-5S |
| Small Item Shelf** | C5-SHELF-S |
| (4) Wire Shelves in Lieu of Universal Slides (full height models)* | C5-SHELFONLY-9S |
| (3) Wire Shelves in Lieu of Universal Slides (3/4 height models)* | C5-SHELFONLY-7S |
| (2) Wire Shelves in Lieu of Universal Slides (1/2 height models)* | C5-SHELFONLY-5S |

*Note: Must order universal slide model ("U")

**Note: Can only be used with universal slides ("U"). Does not work with lip-load slides



Small Item Shelf



Universal Slide

Everyday E-ffordability.



Hold & proof in the same cabinet.

Heated holding & proofing capabilities with one piece of equipment. Go from holding to proofing with the simple flip of a switch.



2000 Watts

More power for food safety.

2000 watt power for increased performance and food safety in holding applications.

Clear, easy-to-open, field reversible door.

Clear door provides visibility to interior contents. Magnetic pull latch provides fast, easy, efficient access to food.

ADJUSTABLE UNIVERSAL SLIDES

HOLD

12X20 / GN PANS & 18X26 PANS



C5 E-Series

Non-insulated holding & proofing cabinets.

Metro's value driven C5® E-Series design provides the right mix of features to economically hold & proof in the same cabinet. Universal slides accommodate a variety of pans and higher power output assures food stays hot, safe, and appetizing. C5 E-Series is a winning combination of the best features, the right price, and top-quality US made construction!

Dimensions

71.4" H (1814mm) x 25.8" W (655mm) x 29.6" D (751mm)

Cabinets

| Electrical | Cat No. | Approx. Pkd. Wt. (lbs.) |
|-------------------|-------------|-------------------------|
| 120V, 60Hz | C5E9-CFC-U | 151 |
| 220-240V, 50/60Hz | C5E9-CXFC-U | 150 |

Accessories (Ship Separately)

| Description | Cat. No. |
|-------------------------------|---------------|
| Small Item Shelf | C5-SHELF-S |
| Universal Slide Pair (Chrome) | C5-USLIDEPR-C |



Pan Capacities

| Slide Pairs | Sheet Pans | Steam Pans | | | | Gastronorm | | | | | |
|-------------|------------|--------------|--------------|------------|------------|------------|-----|-------------|-----|-------------|-----|
| | | 12"x20"x2.5" | 12"x20"x4" | 12"x20"x6" | | 65mm Depth | | 100mm Depth | | 150mm Depth | |
| Provided | Max | 18"x26" | 12"x20"x2.5" | 12"x20"x4" | 12"x20"x6" | 2/1 | 1/1 | 2/1 | 1/1 | 2/1 | 1/1 |
| 12 | 35 | 12* | 24* | 24 | 14 | 12* | 24* | 12 | 24 | 7 | 14 |

Note: Maximum number of slide pairs @ 1.5" spacing. Additional slide pairs ordered separately.
* With additional slide pairs, can accommodate up to: (35) 18x26, (36) 12x20x2.5 or GN 1/1 65mm, (18) GN 2/1 65mm



LEARN MORE



Ergonomic Handles and Bumpers

Steel reinforced polymer handles that double as bumpers; protect the cabinet from impact; and provide ergonomic grab points for easy handling while pushing, pulling, and crossing thresholds.



Intelligent or Basic Controls

Digital control option with mobile power gently circulates air in cabinet and provides temperature alerts while unplugged and in transit!



Heavy-Duty

One piece base bolted to heavy-duty caster channels, reinforced with foamed-in-place polyurethane insulation provides superior rigidity and durability.

Keeps Food Hot for
5 Hours
or Longer.



Uses
50% Less
Energy
than leading
fiberglass
insulated
cabinets!



Foamed-in-Place Insulation

Stainless steel structure with foamed-in-place polyurethane insulation provides superior heat retention and energy efficiency.

C5 T-Series with Transport Armour®

Heavy-duty heated transport cabinets built for over-the-road applications.

Foamed-in-place polyurethane insulation provides SUPERIOR heat retention and structural rigidity. While unplugged and in transit, an available mobile power option gently circulates air inside the cabinet, eliminating hot and cold spots that endanger food safety. The durability, efficiency, and intelligence of the T-Series make it the IDEAL solution for all mobile applications.

Available Sizes

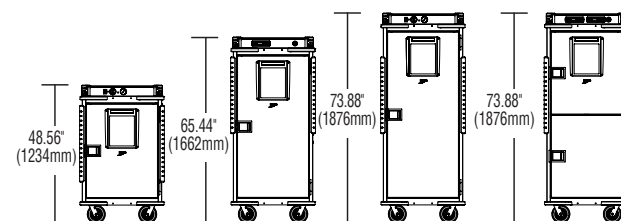

All cabinets are 30" (762mm) wide and 39.25" (997mm) deep.



All T-Series models are ENERGY STAR.



Rigid Door
Foamed-in-place vaulted door for maximum structural integrity. 11-gauge stainless steel hinges, flush paddle latch, and multifunctional information panel.

Slides
Three systems to choose from to hold a variety of pan sizes. Heavy-duty extrusions designed for transport.

Armour Panels
Polymer panels are optimally located to protect the cabinet from facility hazards. Molded-in hand holds create additional grab points.

Mobile Power
Battery powered fan that gently circulates air for superior stratification while cabinet is unplugged and in transit (digital version only).

Uses 50% Less Energy.

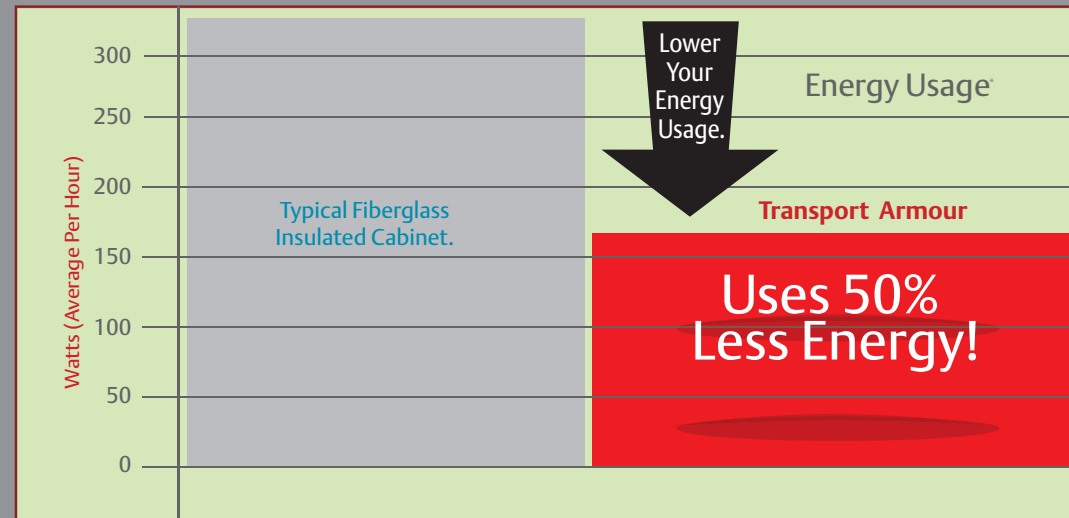

* Average hourly energy consumption. Based off ENERGY STAR Qualification, "Idle Energy, Rate-Dry" test. 150°F cabinet operating temperature. Based off full-height cabinet models.

Keeps Food Hot Twice As Long.

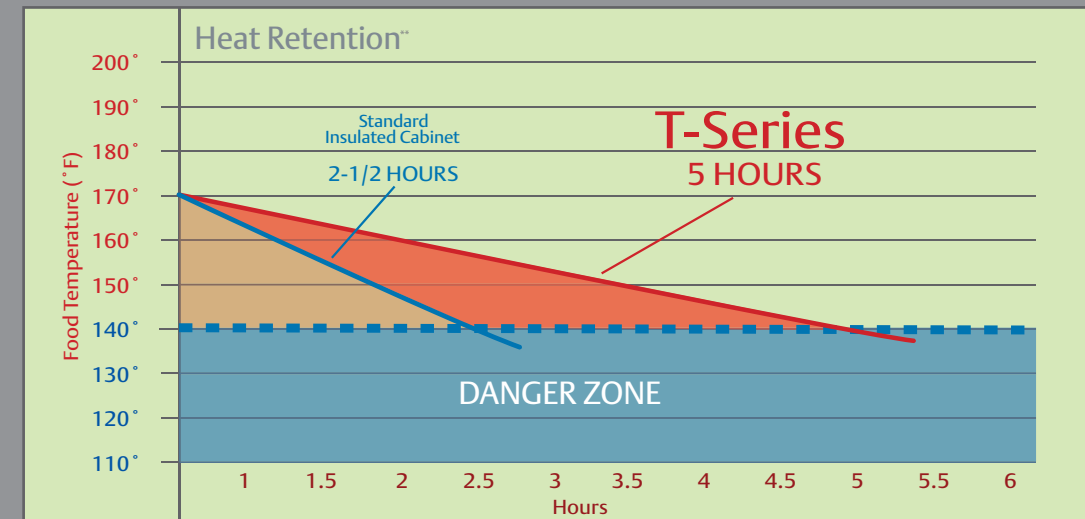

** Average food temperature 170° F, cabinets preheated to 180°F. Four 12" x 20" x 4" uncovered steam pans were placed inside cabinets. Additional food mass and covered pans may result in longer heat retention.

With Energy costs on the rise, reducing energy usage is becoming more and more important. T-Series with Transport Armour® utilizes 50% less Energy than the most efficient fiberglass insulated cabinets. Foamed-in-place polyurethane insulation delivers both Efficiency

Uniform Temperature...

T-Series with Transport Armour®

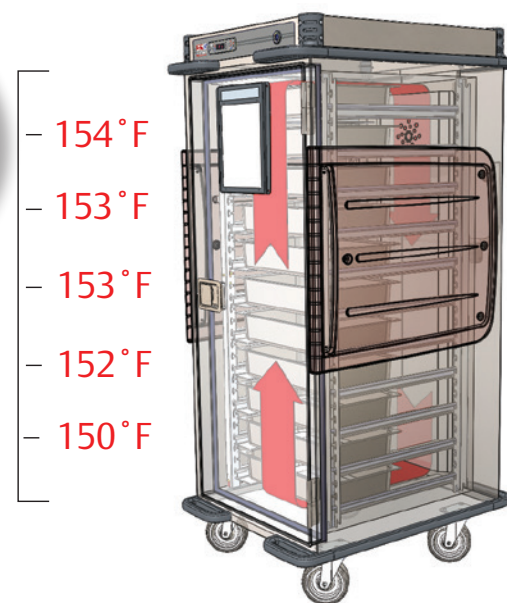

while unplugged.

Traditional Cabinet

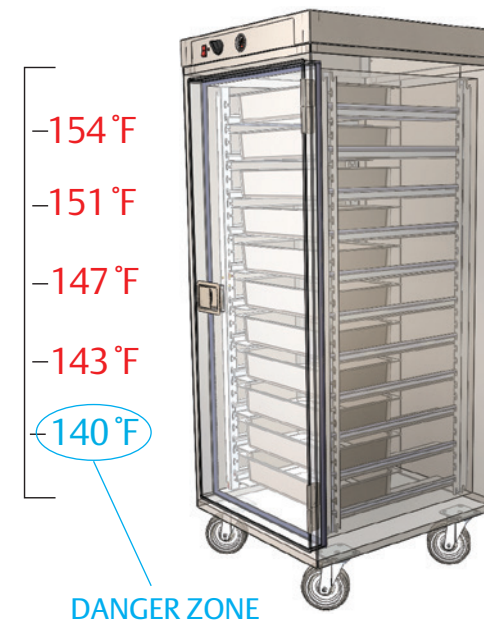

The number one consideration when transporting hot food to satellite locations is keeping food hot, appetizing, and out of the danger zone. Heat retention plays a vital role in the success of any meal delivery program. Foamed-in-place polyurethane insulation keeps food hot while unplugged for **5 hours or longer**, which is more than twice as long as a standard cabinet with fiberglass insulation.

Gentle circulation of air, while unplugged and in transit, eliminates hot and cold spots that endanger food safety. Temperature stratification is 3½ times better with Metro's mobile power option.

To prolong battery life, air circulation and display will shut down after 3 hours. Simply turn unit back on if additional runtime is needed.

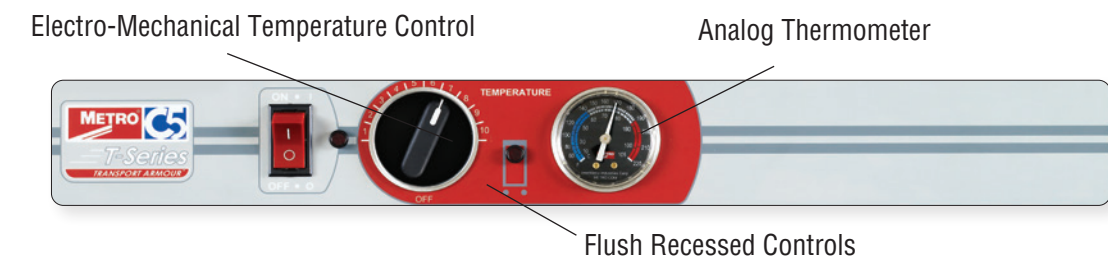
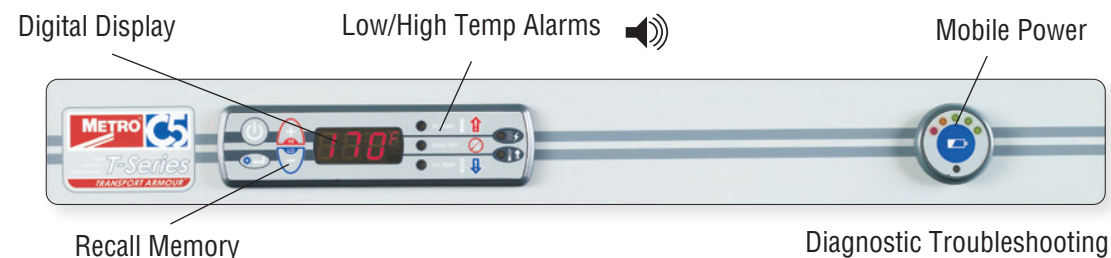

Experience the Benefits.
Keep Food Safe.
T-Series
with Transport Armour®



Use small item shelf option for plated meals or odd sized pans.

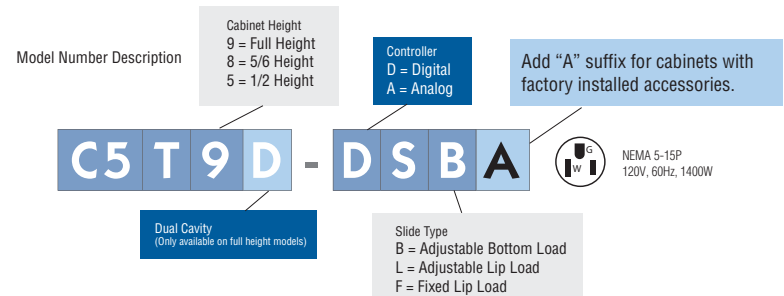

Add "X" for alternate electrical configurations (no upcharge)

C5T9X-DSB NEMA 6-15P
220-240V, 50/60Hz, 1176-1400W

| Controls | Slides | Cat. No. | Approx. Pkd. Wt. (lbs.) |
|--------------------------------|------------------------|------------------|-------------------------|
| Full Height | | | |
| Digital | Adjustable Bottom Load | C5T9-DSB | 490 |
| Digital | Adjustable Lip Load | C5T9-DSL | 482 |
| Digital | Fixed Lip Load | C5T9-DSF | 437 |
| Analog | Adjustable Bottom Load | C5T9-ASB | 484 |
| Analog | Adjustable Lip Load | C5T9-ASL | 476 |
| Analog | Fixed Lip Load | C5T9-ASF | 431 |
| Full Height Dual Cavity | | | |
| Digital | Adjustable Bottom Load | C5T9D-DSB | 509 |
| Digital | Adjustable Lip Load | C5T9D-DSL | 502 |
| Digital | Fixed Lip Load | C5T9D-DSF | 461 |
| Analog | Adjustable Bottom Load | C5T9D-ASB | 503 |
| Analog | Adjustable Lip Load | C5T9D-ASL | 496 |
| Analog | Fixed Lip Load | C5T9D-ASF | 455 |
| 5/6 Height | | | |
| Digital | Adjustable Bottom Load | C5T8-DSB | 456 |
| Digital | Adjustable Lip Load | C5T8-DSL | 449 |
| Digital | Fixed Lip Load | C5T8-DSF | 404 |
| Analog | Adjustable Bottom Load | C5T8-ASB | 450 |
| Analog | Adjustable Lip Load | C5T8-ASL | 443 |
| Analog | Fixed Lip Load | C5T8-ASF | 398 |
| 1/2 Height | | | |
| Digital | Adjustable Bottom Load | C5T5-DSB | 383 |
| Digital | Adjustable Lip Load | C5T5-DSL | 378 |
| Digital | Fixed Lip Load | C5T5-DSF | 337 |
| Analog | Adjustable Bottom Load | C5T5-ASB | 377 |
| Analog | Adjustable Lip Load | C5T5-ASL | 372 |
| Analog | Fixed Lip Load | C5T5-ASF | 331 |

All 120V models with and without accessories are ENERGY STAR.

T-SERIES — {13.9T}

WITH TRANSPORT
ARMOUR®



Adjustable Bottom Load Slides



Adjustable Lip Load Slides



Fixed Lip Load Slides

| Cabinet Size | Slide Pairs | | Sheet Pans | Steam Pans | | | Gastronorm 65mm Depth | |
|-------------------------|-------------|-------|------------|--------------|------------|------------|-----------------------|-----|
| | Provided | Max** | 18"x26" | 12"x20"x2.5" | 12"x20"x4" | 12"x20"x6" | 2/1 | 1/1 |
| Full Height | 16 | 32 | 16 | 32 | 22 | 16 | 16 | 32 |
| Full Height Dual Cavity | 14 | 28 | 14 | 32* | 20* | 16* | 16* | 32* |
| 5/6 Height | 14 | 27 | 14 | 28 | 18 | 14 | 14 | 28 |
| 1/2 Height | 9 | 17 | 9 | 18 | 12 | 8 | 9 | 18 |

*Floor of cabinet used for one pan level, two levels for dual cavity.

**Maximum number of slide pairs @ 1.675" spacing. Additional slide pairs ordered separately.

| Cabinet Size | Slide Pairs | | Sheet Pans | Steam Pans | | | Gastronorm 65mm Depth | |
|-------------------------|-------------|-------|------------|--------------|------------|------------|-----------------------|-----|
| | Provided | Max** | 18"x26" | 12"x20"x2.5" | 12"x20"x4" | 12"x20"x6" | 2/1 | 1/1 |
| Full Height | 16 | 32 | 16 | 32 | 22* | 16 | 16 | 32 |
| Full Height Dual Cavity | 14 | 28 | 14 | 28 | 20* | 12 | 14 | 28 |
| 5/6 Height | 14 | 27 | 14 | 26 | 18 | 12 | 13 | 26 |
| 1/2 Height | 9 | 17 | 9 | 16 | 12* | 8 | 8 | 16 |

*Floor of cabinet used for one pan level, two levels for dual cavity.

**Maximum number of slide pairs @ 1.675" spacing. Additional slide pairs ordered separately.

| Cabinet Size | Slide Levels | Steam Pans | | | Gastronorm | | | | | |
|-------------------------|--------------|--------------|------------|------------|------------|-------------|-------------|-----|---|----|
| | | 12"x20"x2.5" | 12"x20"x4" | 12"x20"x6" | 65mm Depth | 100mm Depth | 150mm Depth | | | |
| | | 2/1 | 1/1 | | 2/1 | 1/1 | 2/1 | 1/1 | | |
| Full Height | 32 | 32 | 22 | 16 | 16 | 32 | 11 | 22 | 8 | 16 |
| Full Height Dual Cavity | 30 | 32 | 20 | 16 | 16 | 32 | 10 | 20 | 8 | 16 |
| 5/6 Height | 27 | 28 | 18 | 14 | 14 | 28 | 9 | 18 | 7 | 14 |
| 1/2 Height | 17 | 18 | 12 | 8 | 9 | 18 | 6 | 12 | 4 | 8 |

ACCESSORIES

Door, Plug, Caster Options

| Description | Cat. No. |
|---|---------------------|
| Travel Latch/Hasp | C5T-TRVL |
| Coiled Cord with Straight Plug (120V, 15 Amp) — in Lieu of Standard | C5T-STRPLG |
| 6" Rear Rigid Casters (pair) — in Lieu of Standard | C5T-6RDGCSTR |
| 8" Semi-Pneumatic Style Casters — in Lieu of Standard | C5T-8SEMPNEU |



C5T-TRVL

Correctional Packages

Includes Lockable Control Panel Cover, Lockable Travel Latch/Hasp, Tamper Proof Screws on Exterior (Padlock NOT included)

| Description | Cat. No. |
|---|--------------------|
| Correctional Package for Dual Cavity Cabinet* | C5T-CORR-9D |
| Correctional Package for Full Height Cabinet | C5T-CORR-9 |
| Correctional Package for 5/6 Height Cabinet | C5T-CORR-8 |
| Correctional Package for 1/2 Height Cabinet | C5T-CORR-5 |

*Note: Includes (2) Lockable Travel Latch / Hasps



Correctional Package

Slide And Shelf Options

| Description | Cat. No. |
|--|------------------------|
| Adjustable Bottom Load Slide Pair (2 pieces) | C5T-BSLIDEPR |
| Adjustable Lip Load Slide Pair (2 pieces) | C5T-LSLIDEPR |
| Small Item Shelf* | C5T-SHELF |
| (4) Wire Shelves — in Lieu of Adjustable Slides (full height/dual cavity models)** | C5T-SHELFONLY-9 |
| (3) Wire Shelves — in Lieu of Adjustable slides (5/6 height models)** | C5T-SHELFONLY-8 |
| (2) Wire Shelves — in Lieu of Adjustable Slides (1/2 height models)** | C5T-SHELFONLY-5 |

*Note: Can only be used with adjustable slides ("B" or "L"). Does not work with fixed lip-load slides

**Note: Must order adjustable slide model ("B" or "L").



Small Item Shelf



LEARN MORE



C5 R-Series with Refrigeration Armour®

**Heavy-duty mobile refrigerators.
Built for transport.**

Engineered to withstand the shock and vibration associated with mobile applications. Stainless steel construction with foamed-in-place polyurethane insulation provides superior rigidity and improved energy efficiency versus common fiberglass construction.

Dimensions

70.13" H (1782mm) x 30" W (762mm) x 39.25" D (997mm)

Well Protected

Protection of the refrigeration system in mobile applications is essential. C5 R-Series features an all-in-one, easily removable refrigeration cassette mounted on vibration/shock isolators for complete refrigeration system protection.



Rigid Door
Foamed-in-place vaulted door for maximum structural integrity. 11-gauge stainless steel hinges and multifunctional information panel.

Slides
Three systems to choose from to hold a variety of pan sizes. Heavy-duty extrusions designed for transport.

Door Latch
Flush mounted, heavy-duty stainless steel paddle latch provides protection during transport.

Wire Shelf Option
Configurable with wire shelves to hold plated meals or odd sized pans and dishes.



Rear Push Handle Option for added control

Easy to move

Stylish, durable armour panels with built-in vertical handles provide protection from impact and ergonomic grab points for easy handling.

Versatile

Perfect for banquet/catering applications that require transport of chilled food to serving locations. Also great for instant back-up capacity in cafeterias and buffet areas.





Model Number Description

C5 R 9 - S B A

Add "A" suffix for cabinets with factory installed accessories.



Slide Type
B = Adjustable Bottom Load
L = Adjustable Lip Load
F = Fixed Lip Load

Add "X" for alternate electrical configurations (no upcharge)

C5R9X-SB NEMA 6-15P
220-240V, 2.7A, 50Hz

R-SERIES — {13.9R}
WITH REFRIGERATION
ARMOUR®

| Electrical | Slides | Cat. No. | Approx. Pkd. Wt. (lbs.) |
|----------------|------------------------|-----------------|-------------------------|
| 120V, 60Hz | Adjustable Bottom Load | C5R9-SB | 490 |
| 120V, 60Hz | Adjustable Lip Load | C5R9-SL | 483 |
| 120V, 60Hz | Fixed Lip Load | C5R9-SF | 438 |
| 220-240V, 50Hz | Adjustable Bottom Load | C5R9X-SB | 490 |
| 220-240V, 50Hz | Adjustable Lip Load | C5R9X-SL | 483 |
| 220-240V, 50Hz | Fixed Lip Load | C5R9X-SF | 438 |



Adjustable Bottom Load Slides

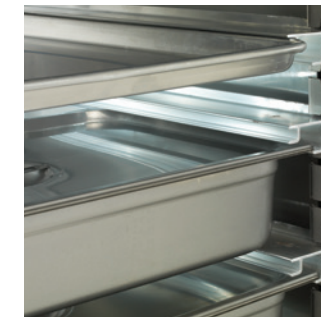

Adjustable Lip Load Slides



Fixed Lip Load Slides

| Slide Type | Slide Pairs | | Sheet Pans | Steam Pans | | | 65mm Depth | | Gastronorm 100mm Depth | | 150mm Depth | |
|------------------------|-------------|-------|------------|--------------|------------|------------|------------|-----|------------------------|-----|-------------|-----|
| | Provided | Max** | 18"x26" | 12"x20"x2.5" | 12"x20"x4" | 12"x20"x6" | 2/1 | 1/1 | 2/1 | 1/1 | 2/1 | 1/1 |
| Adjustable Bottom Load | 13 | 25* | 13** | 26 | 18 | 12 | 13 | 26 | 9 | 18 | 6 | 12 |
| Adjustable Lip Load | 13 | 25* | 13** | 24 | 16 | 12 | 12 | 24 | 8 | 16 | 6 | 12 |
| Fixed lip Load | 26 | 26 | N/A | 26 | 16 | 12 | 13 | 26 | 8 | 16 | 6 | 12 |

*Maximum number of slide pairs @ 1.65" spacing. Additional slide pairs ordered separately.
**Standard capacity @ 3.3" spacing. Increased capacity requires additional slide pairs.

ACCESSORIES

Door, Plug, Rear Handle, Caster Options

| Description | Cat. No. |
|---|---------------------|
| Travel Latch / Hasp | C5T-TRVL |
| Interior Door Release* | C5R-INTDR |
| Straight Plug (120V, 15 Amp) — in lieu of standard | C5-STRPLG-15 |
| Rear Push Handle (U-Shaped) | C5-UHANDLE |
| 6" Rear Rigid Casters (pair) — in lieu of standard | C5T-6RDGCSTR |
| 8" Semi-Pneumatic Style Casters (in lieu of standard) | C5T-8SEMPNEU |

*Note: Required for cabinets sold in Canada.



C5T-TRVL

Correctional Packages

Includes/thermometer Cover, Lockable Travel Latch/Hasp, Tamper Proof Screws on Exterior (Padlock NOT included)

| Description | Cat. No. |
|----------------------|-------------------|
| Correctional Package | C5R-CORR-9 |

Slide And Shelf Options

| Description | Cat. No. |
|---|------------------------|
| Adjustable Bottom Load Slide Pair (2 pieces) | C5T-BSLIDEPR |
| Adjustable Lip Load Slide Pair (2 pieces) | C5T-LSLIDEPR |
| Small Item Shelf* | C5T-SHELF |
| (3) Wire Shelves in Lieu of Adjustable Slides (full height model)** | C5R-SHELFONLY-9 |

*Note: Can only be used with adjustable slides ("B" or "L"). Does not work with fixed lip-load slides
**Note: Must order adjustable slide model ("B" or "L").



PLATED MEAL CAPACITY

with shelf option (C5R-SHELFONLY-9)

| Plate Cover Diameter | Covered Plate Height | | | | | | | |
|--|--------------------------|---------------------------|------------------------|---------------------------|--------------------------|---------------------------|-------------------------|--|
| | 2.5" (63mm) 15 levels | 2.75" (69mm) 14 levels | 3" (76mm) 13 levels | 3.25" (82mm) 12 levels | 3.5" (88mm) 11 levels | 3.75" (95mm) 10 levels | 4" (101mm) 10 levels | |
| Up to 9" (228mm) — 6 per level | 90 | 84 | 78 | 72 | 66 | 60 | 60 | |
| 9.125" to 10" (229 to 254mm) — 5 per level | 75 | 70 | 65 | 60 | 55 | 50 | 50 | |
| 10.125" to 11.75" (255 to 298mm) — 4 per level | 60 | 56 | 52 | 48 | 44 | 40 | 40 | |
| 11.875" to 12.75" (299 to 323mm) — 3 per level | 45 | 42 | 39 | 36 | 33 | 30 | 30 | |
| 12.875" to 14.75" (324 to 374mm) — 2 per level | 30 | 28 | 26 | 24 | 22 | 20 | 20 | |

Shelf spacing for 2.5" (63mm), 2.75" (69mm), 3.25" (82mm), 3.5" (88mm) covered plate heights — (bottom in notch #1, middle in notch #10, top in notch #19).
Shelf spacing for 3" (76mm), 3.75" (95mm), 4" (101mm) covered plate heights — (bottom in notch #1, middle in notch #9, top in notch #17).



Quad-Heat™ unit shown with optional Swing-Up Pull Handle.



MBQ

Heated banquet cabinets that put you in control of time, temperature, and taste.

Engineered to withstand the heavy-duty use and abuse of the real world, while offering one-of-a-kind tools to help improve your operation.

Rugged

Heavy-duty welded, reinforced, stainless steel construction with fiberglass insulation.



Information Panel
Dry-erase white board doubles as a clip board. Integrated thermometer and timer help you keep track time and temperature, all in one convenient place.



Kick Latch
Hands-free access to the cabinet when your hands are full.



Handles
Three-point control handles give you control to move the cabinet from all sides.



Removable Module
Entire module is removable for easy cleaning and servicing.



Intelligent, Ergonomic Features

Unique features like white board information panel, ergonomic handles, and hands-free kick latch provide the tools you need for improved efficiency and maneuverability.

Unique Canned Fuel System

Available Quad-Heat™ dual fuel system combines the standard heating module with a canned fuel back up system, utilizing corner chimneys to evenly distribute heat and eliminate "hot spots" commonly caused by ordinary canned fuel systems.

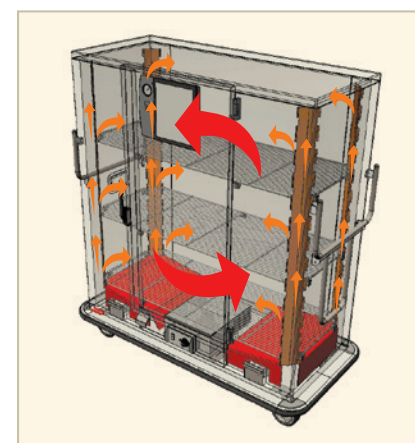

Two-door Banquet Cabinets — {13.32}

Two-door cabinets offer maximum accessibility, come with either standard electric or Quad-Heat™ thermal systems, and are designed to hold 11.75" (298mm) diameter covered plates. Covered plates up to 12.75" (324mm) diameter can be held in smaller quantities. Full-size sheet pans can be held front-to-back in two-door cabinets.

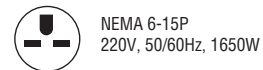

Quad-Heat™ unit shown with optional Swing-Up Pull Handle.

Two-Door Banquet Cabinets

| Thermal System | Stacked | 11.75" Plate Capacity Covered Carrier | Open Capacity Carrier | 12.75" Plate Capacity Stacked | Covered Plates Stacked High | Shelf Size (in.) | Shelves | Shelf Clearance (in.) | Height/Depth/Width (in.) | Shipping Weight (lbs.) | Cat. No. |
|----------------|---------|---------------------------------------|-----------------------|-------------------------------|-----------------------------|------------------|---------|-----------------------|--------------------------|------------------------|--------------------|
| Standard | 200* | 200 | 160 | 160 | 5 | 59x24 | 4 | 14 | 75.0x33.375x67.25 | 633 | MBQ-200D |
| Quad-Heat | 200* | 200 | 160 | 160 | 5 | 59x24 | 4 | 14 | 75.0x33.375x67.25 | 668 | MBQ-200D-QH |
| Standard | 180* | 180 | 150 | 144 | 6 | 59x24 | 3 | 17 | 69.5x33.375x67.25 | 595 | MBQ-180D |
| Quad-Heat | 180* | 180 | 150 | 144 | 6 | 59x24 | 3 | 17 | 69.5x33.375x67.25 | 630 | MBQ-180D-QH |
| Standard | 150* | 150 | 120 | 120 | 5 | 59x24 | 3 | 14 | 60.5x33.375x67.25 | 531 | MBQ-150D |
| Quad-Heat | 150* | 150 | 120 | 120 | 5 | 59x24 | 3 | 14 | 60.5x33.375x67.25 | 566 | MBQ-150D-QH |
| Standard | 120* | 120 | 100 | 96 | 6 | 59x24 | 2 | 17 | 52.0x33.375x67.25 | 483 | MBQ-120D |
| Quad-Heat | 120* | 120 | 100 | 96 | 6 | 59x24 | 2 | 17 | 52.0x33.375x67.25 | 518 | MBQ-120D-QH |

*Capacities based on maximum cover diameter of 11.75" (298mm), plate and cover height of 2.75" (70mm).

To order 220V Model, add "X" to catalog number. (ex. MBQ-200DX)
Add "A" suffix for cabinets with factory installed accessories. (ex. MBQ-200DA)w

Available Sizes

Two-Door Models

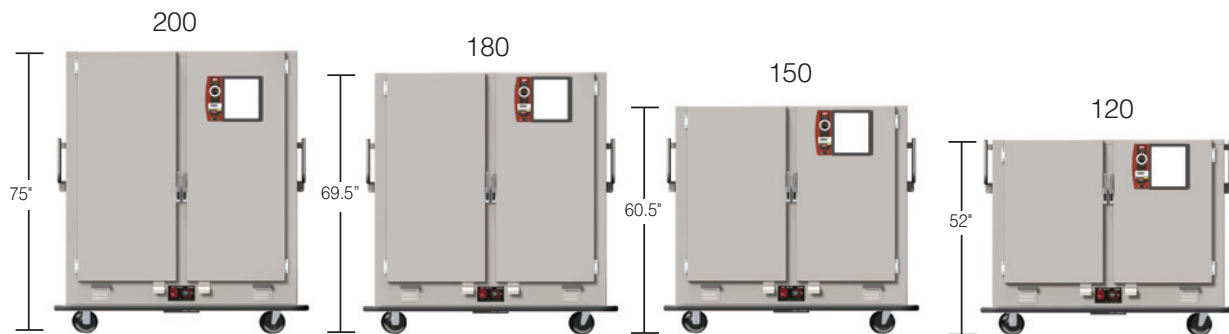

All Double-Door cabinets are 67.25" wide and 33.38" deep

One-Door Banquet Cabinets — {13.33}

One-door cabinets are economical, come with either standard electric or Quad-Heat™ thermal systems, and are designed to hold up to 11" (279mm) diameter covered plates. Smaller capacity cabinets are available in one-door configurations.

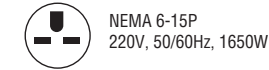

Quad-Heat™ unit shown with optional Swing-Up Pull Handle.

One-Door Banquet Cabinets

| Thermal System | Stacked | 11" Plate Capacity Covered Carrier | Covered Plates Open Carrier | Shelf Stacked High | Size (in.) | Shelves | Shelf Clearance (in.) | Height/Depth/Width (in.) | Shipping Weight (lbs.) | Cat. No. |
|----------------|---------|------------------------------------|-----------------------------|--------------------|------------|---------|-----------------------|--------------------------|------------------------|-------------------|
| Standard | 180* | 180 | 150 | 6 | 55x22 | 3 | 17 | 69.5x30.625x63.625 | 521 | MBQ-180 |
| Quad-Heat | 180* | 180 | 150 | 6 | 55x22 | 3 | 17 | 69.5x30.625x63.625 | 556 | MBQ-180-QH |
| Standard | 144* | 144 | 120 | 6 | 44x22 | 3 | 17 | 69.5x30.625x52.625 | 421 | MBQ-144 |
| Quad-Heat | 144* | 144 | 120 | 6 | 44x22 | 3 | 17 | 69.5x30.625x52.625 | 456 | MBQ-144-QH |
| Standard | 120* | 120 | 96 | 5 | 44x22 | 3 | 14 | 60.5x30.625x52.625 | 408 | MBQ-120 |
| Quad-Heat | 120* | 120 | 96 | 5 | 44x22 | 3 | 14 | 60.5x30.625x52.625 | 443 | MBQ-120-QH |
| Standard | 90* | 90 | 72 | 5 | 33x22 | 3 | 14 | 60.5x30.625x41.625 | 327 | MBQ-90 |
| Quad-Heat | 90* | 90 | 72 | 5 | 33x22 | 3 | 14 | 60.5x30.625x41.625 | 362 | MBQ-90-QH |
| Standard | 72* | 72 | 60 | 6 | 33x22 | 2 | 17 | 52.0x30.625x41.625 | 302 | MBQ-72 |
| Quad-Heat | 72* | 72 | 60 | 6 | 33x22 | 2 | 17 | 52.0x30.625x41.625 | 337 | MBQ-72-QH |

*Capacities based on maximum cover diameter of 11" (279mm), plate and cover height of 2.75" (70mm).

To order 220V Model, add "X" to catalog number. (ex. MBQ-180X)
Add "A" suffix for cabinets with factory installed accessories. (ex. MBQ-180A)

Available Sizes

One-Door Models



Single-Door
63.63" wide and 30.63" deep

Single-Door
52.63" wide and 30.63" deep

Single-Door
41.63" wide and 30.63" deep



BANQUET CABINET ACCESSORIES — {13.34}



Swing-Up Shelf Accessory

Allows middle shelves to be lifted out of the way providing easy access for loading and unloading lower shelves. Available on both one- and two-door models.

| Description | Cat. No. |
|--------------------------|-----------------|
| Swing-Up Shelf Accessory | MBQ-SUSA |



Travel Latch

Provides extra security when traveling longer distances in uncontrolled areas. Lockable design works on both one- and two-door models.

| Description | Cat. No. |
|--------------|-----------------|
| Travel Latch | MBQ-TRVL |

Note: Two required for Top-Mount Cabinets



Caster Upgrades

| Description | Cat. No. |
|---|-----------------|
| 8" (203mm) Caster Upgrade | MBQ-8 |
| 8" (203mm) Semi-Pneumatic Style Caster* | MBQ-8AIR |

*Note: Semi-pneumatic style casters are not available on 200 plate capacity cabinet. (MBQ-200D and MBQ-200D-QH)



NEMA 5-20P

20 Amp Plug For CUL*

| Description | Cat. No. |
|-------------------------|-----------------|
| NEMA 5-20P plug for CUL | MBQ-P20A |

*Note: Required for cabinets destined for Canada.

SWING-UP PULL HANDLE

Provides additional control and visibility when moving the cabinet. Available on both one- and two-door models.

| Description | Cat. No. |
|----------------------|-----------------|
| Swing-Up Pull Handle | MBQ-SUPH |

Mini-Rack

Unique system holds 18"x26" (457x660mm) sheet pans. 12"x20"x3" (305x508x76mm) steamtable pans, or a combination of both. Available for 2 door models only.

| Description | Cat. No. |
|--|------------------|
| Mini-Rack for 200 & 150 Two-Door Models (3 Levels at 3.4" Spacing) | MBQ-MR-14 |
| Mini-Rack for 180 & 120 Two-Door Models (4 Levels at 3.4" Spacing) | MBQ-MR-17 |

CABINET MINI-RACK CAPACITIES

| | |
|----------------------------------|----------------------------------|
| 200 Two-Door holds (8) MBQ-MR-14 | 150 Two-Door holds (6) MBQ-MR-14 |
| 180 Two-Door holds (6) MBQ-MR-17 | 120 Two-Door holds (4) MBQ-MR-17 |

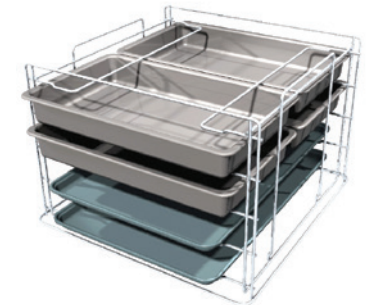

Open Plate Carriers

Wire carrier for holding up to ten uncovered plated meals.

| Description | Cat. No. |
|---|------------------|
| 8-Plate Capacity Carrier for One-Door Cabinets | MBQ-P1-14 |
| 10-Plate Capacity Carrier for One-Door Cabinets | MBQ-P1-17 |
| 8-Plate Capacity Carrier for Two-Door Cabinets | MBQ-P2-14 |
| 10-Plate Capacity Carrier for Two-Door Cabinets | MBQ-P2-17 |

CABINET CARRIER CAPACITIES

| | |
|-----------------------------------|-----------------------------------|
| 200 Two-Door holds (20) MBQ-P2-14 | 144 One-Door holds (12) MBQ-P1-17 |
| 180 Two-Door holds (15) MBQ-P2-17 | 120 One-Door holds (12) MBQ-P1-14 |
| 150 Two-Door holds (15) MBQ-P2-14 | 90 One-Door holds (9) MBQ-P1-14 |
| 120 Two-Door holds (10) MBQ-P2-17 | 72 One-Door holds (6) MBQ-P1-17 |
| 180 One-Door holds (15) MBQ-P1-17 | |



Covered Plate Carriers

Wire carrier for holding up to twelve covered plated meals.

| Description | Cat. No. |
|---|------------------|
| 10-Plate Capacity Carrier for One-Door Cabinets | MBQ-C1-14 |
| 12-Plate Capacity Carrier for One-Door Cabinets | MBQ-C1-17 |
| 10-Plate Capacity Carrier for Two-Door Cabinets | MBQ-C2-14 |
| 12-Plate Capacity Carrier for Two-Door Cabinets | MBQ-C2-17 |

CABINET CARRIER CAPACITIES

| | |
|-----------------------------------|-----------------------------------|
| 200 Two-Door holds (20) MBQ-C2-14 | 144 One-Door holds (12) MBQ-C1-17 |
| 180 Two-Door holds (15) MBQ-C2-17 | 120 One-Door holds (12) MBQ-C1-14 |
| 150 Two-Door holds (15) MBQ-C2-14 | 90 One-Door holds (9) MBQ-C1-14 |
| 120 Two-Door holds (10) MBQ-C2-17 | 72 One-Door holds (6) MBQ-C1-17 |
| 180 One-Door holds (15) MBQ-C1-17 | |



BANQUET CABINET CAPACITIES

| 2 Door Models | Plate & Cover Height | Cover Dia | Plate Capacity | Cover Dia | Plate Capacity | Cover Dia | Plate Capacity |
|---------------|----------------------|--------------|----------------|-------------------|----------------|--------------------|----------------|
| MBQ-200D | up to 2.75" | up to 11.75" | 200 | 11.875" to 12.75" | 160 | 12.875" to 13.125" | 140 |
| | 2.875" - 3.375" | | 160 | | 128 | | 112 |
| | 3.5" - 4.625" | | 120 | | 96 | | 84 |
| | 4.75" - 6.875" | | 80 | | 64 | | 56 |
| | 7" & Over | | 40 | | 32 | | 28 |
| MBQ-180D | up to 2.75" | up to 11.75" | 180 | 11.875" to 12.75" | 144 | 12.875" to 13.125" | 126 |
| | 2.875" - 3.375" | | 150 | | 120 | | 105 |
| | 3.5" - 4.125" | | 120 | | 96 | | 84 |
| | 4.25" - 5.625" | | 90 | | 72 | | 63 |
| | 5.75" - 8.375" | | 60 | | 48 | | 42 |
| 8.5" & Over | 30 | 24 | 21 | | | | |
| MBQ-150D | up to 2.75" | up to 11.75" | 150 | 11.875" to 12.75" | 120 | 12.875" to 13.125" | 105 |
| | 2.875" - 3.375" | | 120 | | 96 | | 84 |
| | 3.5" - 4.625" | | 90 | | 72 | | 63 |
| | 4.75" - 6.875" | | 60 | | 48 | | 42 |
| | 7" & Over | | 30 | | 24 | | 21 |
| MBQ-120D | up to 2.75" | up to 11.75" | 120 | 11.875" to 12.75" | 96 | 12.875" to 13.125" | 84 |
| | 2.875" - 3.375" | | 100 | | 80 | | 70 |
| | 3.5" - 4.125" | | 80 | | 64 | | 56 |
| | 4.25" - 5.625" | | 60 | | 48 | | 42 |
| | 5.75" - 8.375" | | 40 | | 32 | | 28 |
| | 8.5" & Over | | 20 | | 16 | | 14 |

(10) Plates per Level (8) Plates per Level (7) Plates per Level

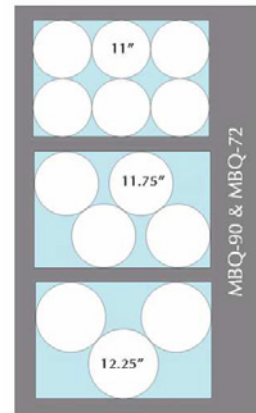
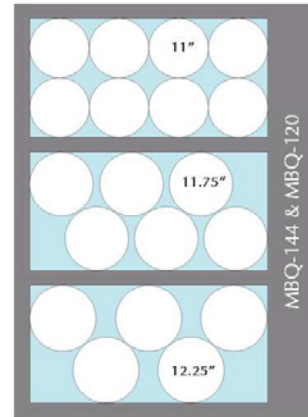
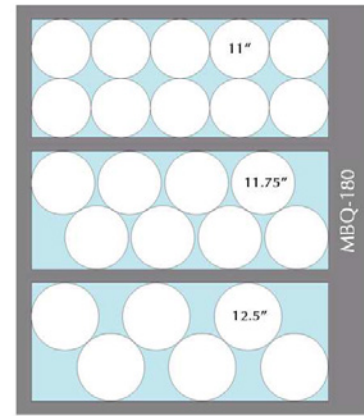
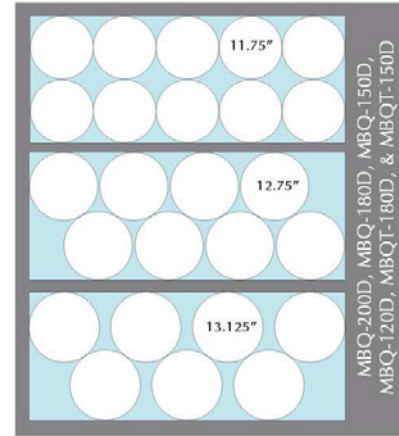

| 1 Door Models | Plate & Cover Height | Cover Dia | Plate Capacity | Cover Dia | Plate Capacity | Cover Dia | Plate Capacity |
|---------------|----------------------|-----------|----------------|-------------------|----------------|------------------|----------------|
| MBQ-180 | up to 2.75" | up to 11" | 180 | 11.125" to 11.75" | 144 | 11.875" to 12.5" | 108 |
| | 2.875" - 3.375" | | 150 | | 120 | | 90 |
| | 3.5" - 4.125" | | 120 | | 96 | | 72 |
| | 4.25" - 5.625" | | 90 | | 72 | | 54 |
| | 5.75" - 8.375" | | 60 | | 48 | | 36 |
| | 8.5" & Over | | 30 | | 24 | | 18 |

(10) Plates per Level (8) Plates per Level (6) Plates per Level

| 1 Door Models | Plate & Cover Height | Cover Dia | Plate Capacity | Cover Dia | Plate Capacity | Cover Dia | Plate Capacity |
|---------------|----------------------|-----------|----------------|-------------------|----------------|-------------------|----------------|
| MBQ-144 | up to 2.75" | up to 11" | 144 | 11.125" to 11.75" | 108 | 11.875" to 12.25" | 90 |
| | 2.875" - 3.375" | | 120 | | 90 | | 75 |
| | 3.5" - 4.125" | | 96 | | 72 | | 60 |
| | 4.25" - 5.625" | | 72 | | 54 | | 45 |
| | 5.75" - 8.375" | | 48 | | 36 | | 30 |
| 8.5" & Over | 24 | 18 | 15 | | | | |
| MBQ-120 | up to 2.75" | up to 11" | 120 | 11.125" to 11.75" | 90 | 11.875" to 12.25" | 75 |
| | 2.875" - 3.375" | | 96 | | 72 | | 60 |
| | 3.5" - 4.625" | | 72 | | 54 | | 45 |
| | 4.75" - 6.875" | | 48 | | 36 | | 30 |
| | 7" & Over | | 24 | | 18 | | 15 |

(8) Plates per Level (6) Plates per Level (5) Plates per Level

| 1 Door Models | Plate & Cover Height | Cover Dia | Plate Capacity | Cover Dia | Plate Capacity | Cover Dia | Plate Capacity |
|---------------|----------------------|-----------|----------------|----------------|----------------|--------------------|----------------|
| MBQ-90 | up to 2.75" | up to 11" | 90 | 11.125" to 12" | 60 | 12.125" to 13.125" | 45 |
| | 2.875" - 3.375" | | 72 | | 48 | | 36 |
| | 3.5" - 4.625" | | 54 | | 36 | | 27 |
| | 4.75" - 6.875" | | 36 | | 24 | | 18 |
| | 7" & Over | | 18 | | 12 | | 9 |
| MBQ-72 | up to 2.75" | up to 11" | 72 | 11.125" to 12" | 48 | 12.125" to 13.125" | 36 |
| | 2.875" - 3.375" | | 60 | | 40 | | 30 |
| | 3.5" - 4.125" | | 48 | | 32 | | 24 |
| | 4.25" - 5.625" | | 36 | | 24 | | 18 |
| | 5.75" - 8.375" | | 24 | | 16 | | 12 |
| | 8.5" & Over | | 12 | | 8 | | 6 |

(6) Plates per Level (4) Plates per Level (3) Plates per Level



HOLDING/DELIVERY/STORAGE CABINETS

Banquet Service Cart — "Queen Mary" — {12.50}

For banquet service, bussing, general back-of-the-house transportation and mobile storage.

- All welded 16-gauge stainless steel construction.
- 8" (203mm) polyurethane casters, two rigid, two swivel.
- Three-Point-Control Handle.
- Wraparound bumper protects cart, walls, and other equipment.
- Optional Swing-Up Pull Handle available.



"Queen Mary"

| Description | Length/Width/Height (in.) | Length/Width/Height (mm) | Approx. Pkd. Wt. (lbs.) | Approx. Pkd. Wt. (kg) | Cat. No. |
|--------------------|---------------------------|--------------------------|-------------------------|-----------------------|----------|
| Five Flat Shelves | 64x31x66 | 1626x787x1651 | 300 | 136 | MQ-512F |
| Six Flat Shelves | 64x31x66 | 1626x787x1767 | 325 | 147 | MQ-609F |
| Five Ledge Shelves | 64x31x65 | 1626x787x1651 | 300 | 136 | MQ-512L |
| Six Ledge Shelves | 64x31x66 | 1626x787x1767 | 325 | 147 | MQ-609L |

For swing-up pull handle, add "-H" to the part number. Example: MQ-609F-H



TC90 Series — Half-Height Heated Insulated Transport Cabinets — {13.28}

- Low center of gravity assures safe transport and use.
- Analog thermometer for consistent and accurate readings, even when unit is not plugged in.
- Stainless interior and removable slide racks provide easy cleaning.
- Convenient kick latch provides "hands-free" easy opening.
- Slide spacing is 2.63" (67mm) lip loaded for steam table pans and bottom loaded for bun pans.



| Cat. No. | Style | Dimensions (HxWxD) | Pan Capacity | | | |
|----------|-------------|-------------------------|--------------------|--------------|-----------------------|------------|
| | | | Sheet Pans 18"x26" | 12"x20"x2.5" | Steam Pans 12"x20"x4" | 12"x20"x6" |
| TC90S | Without | 37" x 21.25" x 24.75" | NA | 9 | 4 | 3 |
| | With Bumper | 37" x 22.44" x 27.25" | NA | 9 | 4 | 3 |
| TC90B | Without | 37" x 27.25" x 30.75" | 9 | NA | NA | NA |
| | With Bumper | 37" x 28 7/16" x 33.25" | 9 | NA | NA | NA |

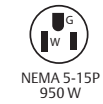

CD Series Cabinets — {13.01}

Designed for enclosed transport and storage of 18"x26" (457x660mm) bun pans.

- 14 gauge high-strength natural finish aluminum, riveted construction and cast aluminum corners.
- Lockable door recedes into sidewall so cabinets occupy minimum space.
- 1.5" (38mm) slide spacing.

| Width/Height/Depth (in.) | Width/Height/Depth (mm) | Inside Height (in.) | Inside Height (mm) | Pan Capacity No. | Approx. Pkd. Wt. (lbs.) | Approx. Pkd. Wt. (kg) | Cat. No. |
|--------------------------|-------------------------|---------------------|--------------------|------------------|-------------------------|-----------------------|----------|
| 21.5x63.25x28 | 533x1607x711 | 52.63 | 1336 | 35 | 85 | 38 | CD3N |
| 21.5x71.5x28 | 533x1816x711 | 60.63 | 1539 | 40 | 95 | 42 | CD4N |

Note: Brakes are standard on two casters, for the units listed above.

Accessories

| Description | Model |
|-------------------------|-------|
| Gray Corner Bumpers | A32 |
| *Gray Continuous Bumper | A33 |
| Floor Lock | A71 |

*Adds 2" (51mm) to overall width and depth of rack.



CD3N



RD3N NSF

End-Load Racks — Single Section — {13.50}

- Units feature sturdy, riveted 6063-T6 aluminum construction. Pass-thru design affords maximum convenience.
- Space saving, ideal for freezers, coolers, bakeries.

| Width/Height/Depth (in.) (mm) | | Slide Spacing (in.) (mm) | | Pan Capacity Size (in.) (mm) | | Approx. Pkd. Wt. (lbs.) (kg) | | Cat. No. |
|-------------------------------|--------------|--------------------------|-----|------------------------------|---------------------|------------------------------|------|----------|
| 21.5x69.75x29 | 546x1772x736 | 3 | 76 | 20 | 18x26 457x660 Pans | 52 | 23.6 | RD3N |
| | | | | or 40 | 14x18 355x457 | | | |
| 21.25x69.75x26.5 | 546x1772x673 | 1.5 | 38 | 40 | 18x26 457x660 Pans | 52 | 23.6 | RD13N |
| 20x63.75x23 | 508x1619x584 | 3 | 76 | 18 | 15x20 381x508 Trays | 49 | 22.2 | RD15N |
| | | | | or 18 | 16x22 406x553 | | | |
| 21.5x69.75x29 | 546x1772x736 | 5 | 127 | 12 | 18x26 457x660 Pans | 45 | 20.4 | RD23N |
| | | | | or 24 | 14x18 355x457 | | | |

Note: 5" (127mm) swivel casters, two with brakes, are standard on units listed above. Weight Load Capacity: 20 lbs. (9kg) per slide; 350 lbs. (159kg) per rack.

Accessories

| Description | Model |
|-------------------------|-------|
| *Gray Continuous Bumper | A33RD |
| **Gray Corner Bumpers | A37 |
| Pan Stop | A120 |

*Adds 2" (51mm) to overall width and depth of rack.
 **Adds .5" (12.7mm) to overall width and 1" (25mm) to overall depth of rack.
 Notes: Accessories must be ordered with rack. Not designed for field installation. Accessorized racks shipped assembled. Part numbers will be combined to signify complete unit at time of order entry.



RD33N NSF

Side-Load Rack — Single Section — {13.52}

| Width/Height/Depth (in.) (mm) | | Inside Height (in.) (mm) | | Slide Spacing (in.) (mm) | | Pan Capacity Size (in.) (mm) | | Approx. Pkd. Wt. (lbs.) (kg) | | Cat. No. |
|-------------------------------|--------------|--------------------------|------|--------------------------|----|------------------------------|---------------|------------------------------|------|----------|
| 29.38x69.25x18.63 | 746x1758x472 | 60.5 | 1536 | 3 | 76 | 20 | 18x26 457x660 | 45 | 20.2 | RD33N |

Note: 5" (127mm) swivel casters, two with brakes, are standard on units listed above. Weight Load Capacity: 20 lbs. (9kg) per slide level; 350 lbs. (159kg) per rack. Allowable temperature range: -30°F (-34°C) to 160°F (71°C).

Adjustable Rack — {13.56}

Ideal for holding a variety of items of different sizes at different times.

- 13 Sets of "Vari-Slides" accommodate all popular modules used in the foodservice industry.
- Made of special extrusion (.100" or 2.5mm thick) with bending support design for heavy loads.
- Keyholes in uprights on 1.5" (38mm) spacing. Inside height is 60.25" (1530mm).



RD78N NSF

| Width/Height/Depth (in.) (mm) | | 2 per Slide Size (in.) (mm) | | 1 per Slide Size (in.) (mm) | | Approx. Pkd. Wt. (lbs.) (kg) | | Cat. No. |
|-------------------------------|--------------|-----------------------------|--------------------|-----------------------------|---------------|------------------------------|------|----------|
| 24.38x69.5x26 | 619x1765x660 | 26 | 10.83x19.75274x501 | 13 | 15x20 380x520 | 93 | 41.8 | RD78N |
| | | 26 | 11.13x20 284x508 | 13 | 18x26 457x660 | | | |
| | | 26 | 12x18 304x457 | 13 | 20x20 508x508 | | | |
| | | 26 | 12x20 304x508 | 13 | 20x22 508x558 | | | |
| | | 26 | 13x18 330x457 | 13 | 20x24 508x609 | | | |
| | | 26 | 14x18 335x457 | | | | | |

*Vertical supports punched on 1.5" (38mm) centers for adjustability.
 Note: 5" (127mm) heavy-duty swivel casters with neoprene wheels, two with brakes, are standard on unit listed above.
 Notes: Accessories must be ordered with rack. Not designed for field installation. Accessorized racks shipped assembled. Part numbers will be combined to signify complete unit at time of order entry. Weight Load Capacity: 50 lbs. (22.7kg) per slide level; 350 lbs. (159kg) per rack. Allowable temperature range: -30°F (-34°C) to 160°F (71°C).

Accessories

| Description | Model |
|--|-------|
| *Gray Continuous Bumper | A33RD |
| **Gray Corner Bumpers | A37 |
| Extra Slides (Will take 4 extra pair max.) | A121 |
| Floor Lock | A71 |
| Pan Stop | A120 |

*Adds 2" (51mm) to overall width and depth of rack.
 **Adds .5" (12.7mm) to overall width and 1" (25mm) to overall depth of rack.



End-Load "Knock Down" Racks — Single Section — {13.70}

| Width/Height/Depth (in.) (mm) | | Inside Height (in.) (mm) | | Slide Spacing (in.) (mm) | | Pan Capacity Size (in.) (mm) | | Approx. Pkd. Wt. (lbs.) (kg) | | Cat. No. |
|-------------------------------|--------------|--------------------------|------|--------------------------|---------------|------------------------------|---------------|------------------------------|------|----------|
| 20.38x64.13x28 | 518x1630x711 | 55.88 | 1417 | 3 | 76 | 18 | 18x26 457x660 | 53 | 23.8 | RT183N |
| | | | | or 36 | 14x18 355x457 | | | | | |
| 20.38x64.13x28 | 518x1630x711 | 55.88 | 1417 | 5 | 127 | 11 | 18x26 457x660 | 50 | 22.5 | RT115N |
| | | | | or 22 | 14x18 355x457 | | | | | |
| 20.38x64.13x28 | 518x1630x711 | 55.88 | 1417 | 1.5 | 28 | 34 | 18x26 457x660 | 55 | 24.7 | RT1334N |

Note: 5" (127mm) swivel casters, two with brakes, are standard on units listed above. Weight Load Capacity: 20 lbs. (9kg) per slide level; 300 lbs. (136kg) per unit. Allowable temperature range: -30°F (-34°C) to 160°F (71°C).



RT115N NSF

Side-Load "Knock Down" Racks — {13.72}

| Width/Height/Depth (in.) (mm) | | Inside Height (in.) (mm) | | Slide Spacing (in.) (mm) | | Pan Capacity Size (in.) (mm) | | Approx. Pkd. Wt. (lbs.) (kg) | | Cat. No. |
|-------------------------------|--------------|--------------------------|------|--------------------------|-----|------------------------------|---------------|------------------------------|------|----------|
| 28.38x64.13x18.75 | 721x1628x476 | 56.5 | 1435 | 3 | 76 | 18 | 18x26 457x660 | 40 | 18 | RT3318N |
| 28.38x64.13x18.75 | 721x1628x476 | 56.5 | 1435 | 5 | 127 | 11 | 18x26 457x660 | 38 | 17.1 | RT3511N |

Note: 5" (127mm) swivel casters, two with brakes, are standard on units listed above. Weight Load Capacity: 20 lbs. (9kg) per slide level; 300 lbs. (136kg) per rack. Allowable temperature range: -30°F (-34°C) to 160°F (71°C).



RT3318N NSF



RF13N



Roll-In Refrigerator Racks — {13.80}

Rack rolls directly into refrigerator for quick and easy storage.

- Natural finish, high-strength, extruded aluminum (6063-T6 alloy), riveted construction.
- Pass-Thru Design can be loaded on one side and unloaded from the other for maximum efficiency and convenience.

| Width/Height/Depth (in.) | Width/Height/Depth (mm) | Slide Spacing (in.) | Slide Spacing (mm) | Pan Capacity | | Approx. Pkd. Wt. (lbs.) (kg) | Cat. No. |
|--------------------------|-------------------------|---------------------|--------------------|--------------|-----------------|------------------------------|--------------|
| | | | | No. | Size (in.) (mm) | | |
| 21.25x64.75x26 | 539x1645x660 | 1.5 | 38 | 36 | 18x26 457x660 | 44 19.8 | RF13N |
| 21.38x64.75x26 | 543x1645x660 | 3 | 76 | 18 | 18x26 457x660 | 55 24.7 | RF3N |
| 21.38x64.75x26 | 543x1645x660 | 5 | 127 | 11 | 18x26 457x660 | 43 19.3 | RF23N |

| Width/Height/Depth (in.) | Width/Height/Depth (mm) | Pan Capacity with (12) Standard Sets of Slides on 4 1/2" (114mm) Centers* | | | | Approx. Pkd. Wt. (lbs.) (kg) | Cat. No. | |
|--------------------------|-------------------------|---|-----------------|------------------|-----------------|------------------------------|----------|--------------|
| | | 2 per Slide Size | | 1 per Slide Size | | | | |
| | | No. | Size (in.) (mm) | No. | Size (in.) (mm) | | | |
| 24.38x64.5x26 | 619x1688x660 | 24 | 10.88x19.75 | 274x501 | 12 | 15x20 380x520 | 92 41.4 | RF78N |
| | | 24 | 11.13x20 | 284x508 | 12 | 18x26 457x660 | | |
| | | 24 | 12x18 | 304x457 | 12 | 20x20 508x508 | | |
| | | 24 | 12x20 | 304x508 | 12 | 20x22 508x558 | | |
| | | 24 | 13x18 | 330x457 | 12 | 20x24 508x609 | | |
| | | 24 | 14x18 | 335x457 | | | | |

*Vertical supports punched on 1.5" (38mm) centers for adjustability.
 Note: 5" (127mm) swivel casters, two with brakes, are standard on units listed above.
 Weight Load Capacity: 20 lbs. (9kg) per slide level; 350 lbs. (159kg) per rack.
 Allowable temperature range: -30°F (-34°C) to 160°F (71°C).

Accessories

| Description | Model |
|--------------------------------------|--------------|
| *Gray Continuous Bumper | A33RD |
| **Gray Corner Bumpers | A37 |
| Extra Slides for RF78N | A121 |
| Floor Lock (for use with RF78N Only) | A71 |
| Pan Stop | A120 |

*Adds 2" (51mm) to overall width and depth of rack.
 **Adds .5" (12.7mm) to overall width and 1" (25mm) to overall depth of rack.
 Notes: Accessories must be ordered with rack. Not designed for field installation. Accessorized racks shipped assembled. Part numbers will be combined to signify complete unit at time of order entry.

Oval Tray Rack — {13.58}

Special design, natural finish, high-strength, extruded aluminum (6063-T6 alloy) framework with 8-gauge brake-formed slides. Pass-thru design is lightweight, maneuvers easily. Ideal for banquet service.

| Width/Height/Depth (in.) | Width/Height/Depth (mm) | Slide Spacing (in.) | Slide Spacing (mm) | Pan Capacity | | Approx. Pkd. Wt. (lbs.) (kg) | Cat. No. |
|--------------------------|-------------------------|---------------------|--------------------|--------------|---------------------|------------------------------|--------------|
| | | | | No. | Size (in.) (mm) | | |
| 27x70.25x29 | 685x1784x736 | 6 | 152 | 10 | 22.75x27.63 577x701 | 88 39.6 | RD27N |

Note: 5" (127mm) heavy-duty swivel casters with neoprene wheels, two with brakes, are standard on unit listed above.
 Weight Load Capacity: 50 lbs. (22.7kg) per slide level; 350 lbs. (159kg) per rack.
 Allowable temperature range: -30°F (-34°C) to 160°F (71°C).

Accessories

| Description | Model |
|-------------------------|--------------|
| *Gray Continuous Bumper | A33RD |
| **Gray Corner Bumpers | A37 |
| Pan Stop | A120 |
| Floor Lock | A71 |

*Adds 2" (51mm) to overall width and depth of rack.
 **Adds .5" (12.7mm) to overall width and 1" (25mm) to overall depth of rack.
 Notes: Accessories must be ordered with rack. Not designed for field installation. Accessorized racks shipped assembled. Part numbers will be combined to signify complete unit at time of order entry.



RF78N



RD27N

End-Load and Side-Load Wire Bun Pan Racks — {13.42}

Economical solution for storage and transport of bun pans.

- End-load models provide a large tray landing area, side-load models are highly space efficient.
- Choice of 1.5" (38mm) spacing (38 pans) or 3" (76mm) (20 pans) spacing.
- Quick, easy no-tool assembly, rolls easily on 5" (127mm) swivel casters.
- Durable Super Erecta Brite™ finish.
- All units are 69" (1752mm) high.

| Width/Length (in.) | Width/Length (mm) | Slide Spacing (in.) | Slide Spacing (mm) | Pan Capacity | | Approx. Pkd. Wt. (lbs.) (kg) | Description | Cat. No. |
|--------------------|-------------------|---------------------|--------------------|--------------|-----------------|------------------------------|-------------|------------|
| | | | | No. | Size (in.) (mm) | | | |
| 21.75x27 | 552x685 | 1.5 | 38 | 38 | 18x26 457x660 | 61 27.7 | End-Load | RE1 |
| 21.75x27 | 552x685 | 3 | 76 | 20 | 18x26 457x660 | 70 31.8 | End-Load | RE3 |
| 19.5x30 | 495x762 | 1.5 | 38 | 38 | 18x26 457x660 | 61 27.6 | Side-Load | RS1 |
| 19.5x30 | 495x762 | 3 | 76 | 20 | 18x26 457x660 | 70 31.8 | Side-Load | RS3 |

Weight Load Capacity: 30 lbs. (13.6kg) per level; 200 lbs. (91kg) per rack.

Accessories

| Description | Model |
|---|---------------|
| 3.5" (90mm) Diameter Rubber Donut Bumper | 9992DB |
| 5.5" (140mm) Diameter Rubber Donut Bumper | 9992N |



Side Load End Load Wire Bun Pan Racks

Portable Wire Prep Rack — {13.44}

Made to accommodate standard 18"x26" (457x660mm) trays or pans.

- The .5" (12.7mm) food grade polyethylene cutting board/work surface provides an area for slicing, mixing, garnishing or other types of food preparation.
- Rolls easily on 5" (127mm) swivel casters.
- Units assemble quickly and easily without special tools.

| Width/Length (in.) | Width/Length (mm) | Height (in.) | Height (mm) | Slide Spacing (in.) | Slide Spacing (mm) | Pan Capacity | | Approx. Pkd. Wt. (lbs.) (kg) | Description | Cat. No. |
|--------------------|-------------------|--------------|-------------|---------------------|--------------------|--------------|-----------------|------------------------------|-------------|-------------|
| | | | | | | No. | Size (in.) (mm) | | | |
| 21.75x27 | 550x685 | 36 | 914 | 1.5 | 38 | 16 | 18x26 457x660 | 50 22.6 | End-Load | RE1P |
| 21.75x27 | 550x685 | 36 | 914 | 3 | 76 | 8 | 18x26 457x660 | 60 27.2 | End-Load | RE3P |

Accessories

| Description | Model |
|---|---------------|
| 3.5" (90mm) Diameter Rubber Donut Bumper | 9992DB |
| 5.5" (140mm) Diameter Rubber Donut Bumper | 9992N |



Portable Wire Prep Rack



Soup to nuts solutions.

GROCERY, RETAIL, SPECIALITY, & WARE HANDLING SOLUTIONS

- Grocery, Retail, Speciality & Ware Handling 234-258
- Grocery Solutions..... 236-247
- Retail Solutions..... 248-251
- Beer and Wine Storage & Accessories..... 252-253
- Mini Bar Restocking Cart 254
- Linen Trucks & Carts 255
- “Poker Chip” Dish Dollies..... 256-257
- Side-Load Dish and Tray Carts 258



Super-duper supermarket. pg. 80-83

Drop Mat qwikSLOT®



pg. 46
Super Erecta®



Create unique
displays using pushers,
hooks, pegboard &
baskets.



pg. 179
C5 Heated Cabinets



Super Erecta Specialty

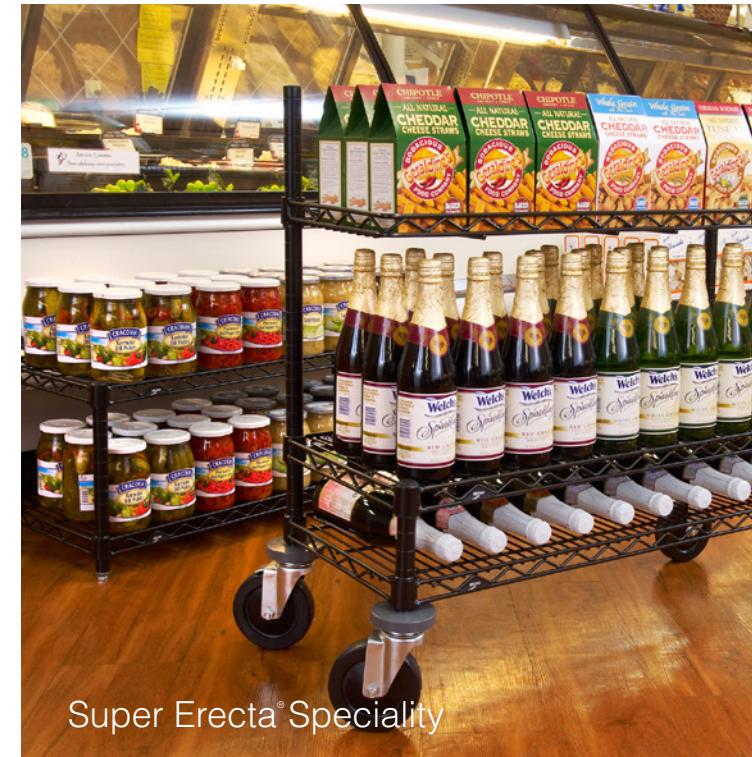

Super Erecta Specialty



Great for Retail Display.

Research shows sales and profits increase more than **43%**.

Data was collected from ten stores operated by three food retailers in the United States. The research covered 15 product categories and thousands of items. The research was conducted by Willard Bishop Consulting Ltd. and involved two areas of research:

- In-store merchandising tests and point-of-sale data analysis to quantify sales/profits and total category impact.
- Consumer focus groups to qualify consumer reaction.

Sales and profits for specialty items increased more than 43%. Total category performance demonstrated a 12+% increase in sales and 14+% increase in profits.

Uniquely profitable.

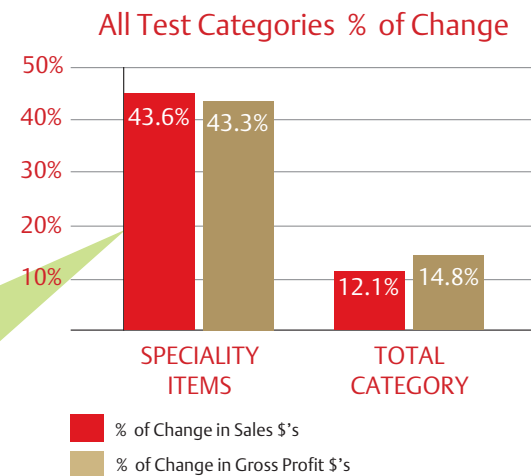

qwikSLOT® Display Shelving makes creating your Store-Within-A-Store simple and easy.



pg. 81



Get Maximum Retail Density.

Drop Mat Display Shelving.
Increase your shelving holding power by up to **30%**.

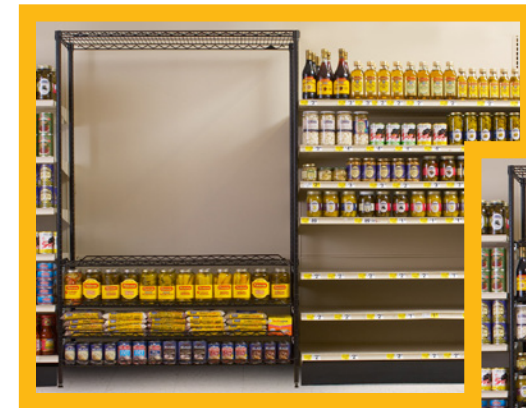

Drop Mat yields space saving results. The space gain is undeniable.



RECLAIMED SPACE

Quick-to-set, Quick-to-profit.



What's the secret to increasing holding power?

- The secret to Metro's space-saving advantage is Drop Mat's "thin shelf" design (1/4" versus 1 1/2"). Drop Mat eliminates the need for space robbing under-shelf supports and bulky shelf brackets, reclaiming 20% of your merchandising space.
- Back-to-back, Drop Mat saves yet more space. Reclaim up to 10% additional space by eliminating traditional gondola's 4" wide center support structure.



pg. 82



Store it like the pros.
pg. 34-93



12 YEAR CORROSION WARRANTY

NSF



pg. 46
Super Erecta® Metroseal

Super Adjustable Super Erecta® Metroseal

RUST RESISTANT COATED WIRE

Basic Storage and Transport for ALL Environments.

- ✓ ANTIMICROBIAL PROTECTION
- ✓ 12 YEAR CORROSION WARRANTY
- ✓ EASY-ADJUST OPTIONS
- ✓ HOLDS UP TO 800 LBS. PER SHELF (363kg)



pg. 120
Wall Shelving



Safely Hold up to 800lbs. per shelf.

pg. 36
Super Erecta® Pro

RUST RESISTANT COATED WIRE with Removable Shelf Mats

Advanced Storage and Transport for ALL environments

- ✓ EASY-TO-CLEAN REMOVABLE MATS
- ✓ ANTIMICROBIAL PROTECTION
- NSF
- MICROBAN



NSF

Safely Hold up to 800lbs. per shelf.

pg. 46
Super Erecta®

Super Erecta® Chrome & Brite Super Adjustable Super Erecta® Chrome & Brite

TRADITIONAL WIRE

Basic Storage and Transport for Dry Environments.

- 😊 EASY-ADJUST OPTIONS
- 😊 HOLDS UP TO 800 LBS. PER SHELF (363kg)



MetroMax[®] 4

100% RUST-PROOF ALL-POLYMER

Corrosion proof performance, proven Metro stability, and unrivaled value.

- ✓ **LIFETIME** CORROSION WARRANTY
- ✓ EASY-TO-CLEAN, REMOVABLE MATS
- ✓ HOLDS UP TO **800 LBS.** PER SHELF (363kg)
- PROTECTION THAT LIVES ON **MICROBAN**



MetroMax[®] i

100% RUST-PROOF ALL-POLYMER
with Super Strong Stainless Steel Corners

The strongest, most versatile, corrosion proof shelving system in the world.

- ✓ **LIFETIME** CORROSION WARRANTY
- ✓ EASY-TO-CLEAN, REMOVABLE MATS
- ✓ HOLDS UP TO **1000 LBS.** (454kg) PER SHELF
- ✓ **2000 LBS.** (907kg) PER UNIT
- ✓ **900 LBS.** (454kg) PER MOBILE UNIT
- ✓ TEAR RESISTANT SURFACES



MetroMax[®] Q

RUST RESISTANT POLYMER & COATED WIRE
with Removable Shelf Mats

Quick adjustment, corrosion resistance and the strength of steel.

- 😊 **15-YEAR** CORROSION WARRANTY
- 😊 EASY-TO-CLEAN, REMOVABLE MATS
- 😊 HOLDS UP TO **800 LBS.** (363kg) PER SHELF
- 😊 **2000 LBS.** (907kg) PER UNIT
- 😊 **900 LBS.** (454kg) PER MOBILE UNIT
- PROTECTION THAT LIVES ON **MICROBAN**



pg. 100-110

High-density track shelving for coolers, freezers, & more.

Top-Track™

Guide track on top allows for easy active aisle access and floor cleaning. Works with Super Erecta & MetroMax series shelves.



qwikTRAK™

Guide track on bottom keeps floors from wear and tear over time. Works with Super Erecta & Max series shelves.



The easiest way to build track shelving.



Pick, sort, store & transport orders faster and more efficiently.

- Multiple Order Picking Capacity
- Easy to Maneuver
- Quick Tote Access
- Great for Stocking
- Holds Laptop or iPad

Let us help you configure a cart to meet your grocery application.

Online Ordering Picking Carts

Universal Picking Cart

Ideal solution for retail and grocery stores looking to improve their online ordering pickup process. Includes three spacious, easy-to-clean totes for organizing customer items, two solid 14" x 24" shelves for storing bulk items, a wire basket to hold employee tools such as handheld scanners and clipboards, and a push handle for ultimate control.

| Description | Size (in) (W x L x H) | Size (mm) (W x L x H) | Cat. No. |
|---------------------------|--------------------------|--------------------------|-------------|
| 24x36 Mobile Picking Cart | 24x38x40 | 610x965x1016 | CR243840-PC |



High-Capacity Picking Cart

Ideal solution for retail and grocery stores looking to improve their online ordering pickup process. Includes six spacious, easy-to-clean totes for organizing customer items, a wire basket to hold employee tools such as handheld scanners and clipboards, and a push handle for ultimate control.

| Description | Size (in) (W x L x H) | Size (mm) (W x L x H) | Cat. No. |
|---------------------------|--------------------------|--------------------------|-------------|
| 24x36 Mobile Picking Cart | 24x38x54 | 610x965x1372 | CR214254-PC |





Ultra light

pg. 174
Insulated Food Carriers



pg. 30

MetroMax[®] i
Drying Racks
With Advanced Water Capture



pg. 179
Holding Cabinets



pg. 158
PrepMate
Prep Tables



ADJUSTABLE
5 Working Heights

Efficient.

From farm to table, chop, dice & slice through vegetables with the highest efficiency. Utilize the PrepMate rail system with stock below on one side and push prepped food directly into waiting pans on the other.



pg. 170
Heated Shelving



pg. 148
Utility Carts



The look that sells. pg. 46

Super Erecta®



Super Erecta® Specialty



Super Erecta®

A premium look with flexibility to adapt to any décor or retail theme.



Super Erecta®

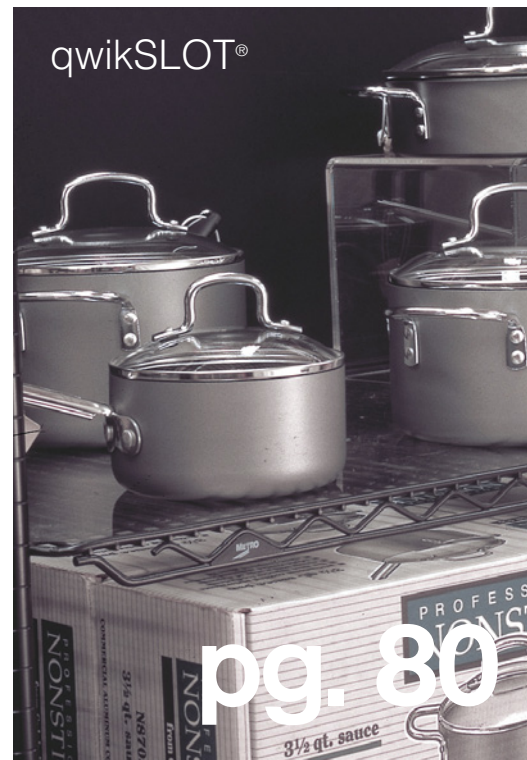

qwikSLOT®

pg. 80



Super Erecta®





Basket Cart

Easy access and mobility, Metro Basket Carts are perfect for POP displays. Available in multiple height options, baskets can hold up to 250 lbs. (113kg)

| Description | Height | | Cat. No. |
|---|--------|------|-----------------------|
| | (in.) | (mm) | |
| 18"x24" (457x610mm) Black Finish (4) 8" Deep Wire Basket Cart | 68 | 1727 | PKM4BSK182463B |
| 18"x24" (457x610mm) Black Finish (2) 8" Deep Wire Basket Cart | 37 | 864 | PK2387 |



Basket Shelf
(Posts sold separately, see page 46)

Basket Shelf — {10.04}

3.5" (89mm) deep basket with 400 lbs. (182kg) weight capacity. Ideal for cross merchandising in front of display cases or driving impulse sales.

| Size (in.) | Size (mm) | Cat. No. Chrome | Cat. No. Black |
|---------------|--------------|--------------------|-------------------|
| | | | |
| 14x48 | 355x1219 | — | DD3448B |
| 18x36 | 457x914 | CC9744A | CC9744C |
| 18x48 | 457x1219 | CC9744 | CC9744B |

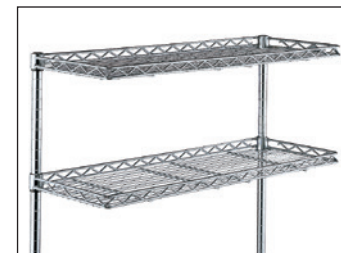

Cantilever Shelves

Cantilever Shelves — {10.06}

Adds convenient space above a storage unit. Drop mat design creates a retaining ledge around the entire 12" (305mm) deep shelf. See page 46.



Post Connectors — {10.15}

Attach posts of upper shelves to lower level frame or mat to create tiered shelving.

| Type of Connectors | Finish | Approx. Pkd. Wt. (lbs.) (kg) | | Cat. No. |
|-----------------------|--------|------------------------------|----|-------------|
| 4 Post-to-Shelf Frame | Black | 1 | .5 | HFCB |
| 4 Post-to-Shelf Mat | Black | 2 | 1 | HMCB |
| 4 Post-to-Shelf Mat | Chrome | 2 | 1 | HMCC |



Tiered Shelving with Post Connectors

Display Platforms — {10.44}

Super Erecta Display Platforms are ideal for displaying large, bulky items, boxed goods or cross merchandising. All platforms come with one shelf and four 13" (330mm) posts.

| Width/Length (in.) (mm) | | Approx. Pkd. Wt. (lbs.) (kg) | | Cat. No. Chrome |
|-------------------------|---------|------------------------------|-----|-----------------|
| 18x24 | 457x610 | 11 | 5.0 | P1824NC |
| 18x30 | 457x760 | 12 | 5.5 | P1830NC |
| 18x36 | 457x914 | 13 1/2 | 6.1 | P1836NC |
| 21x24 | 530x610 | 12 | 5.5 | P2124NC |
| 21x30 | 530x760 | 13 | 5.9 | P2130NC |
| 21x36 | 530x914 | 15 | 6.8 | P2136NC |
| 24x24 | 610x610 | 13 | 5.9 | P2424NC |
| 24x30 | 610x760 | 15 | 6.8 | P2430NC |
| 24x36 | 610x914 | 17 | 7.7 | P2436NC |



Display Platforms (Shown with one optional/additional shelf)

Slanted-Shelf Merchandisers

A premium presentation, slanted shelves add visibility and accessibility. Loading is quick, easy, and organized.

- Open wire construction and slope of shelves promote visibility.
- Shelves are adjustable at 1" (25mm) intervals along the height of the post.
- 5" (127mm) casters add mobility, while brakes lock firmly in position.

| Width (in.) (mm) | Length (in.) (mm) | Height (in.) (mm) | Approx. Pkd. Wt. (lbs.) (kg) | Shelves | Cat. No. | | | | |
|------------------|-------------------|-------------------|------------------------------|---------|----------|-----|------|---|---------------|
| 18 | 457 | 24 | 610 | 60 | 1524 | 103 | 46.3 | Four Slanted Shelves One Flat Top Shelf (Pkg. of 12 dividers) | DC15EC |
| 18 | 457 | 24 | 610 | 60 | 1524 | 112 | 50.4 | Five Slanted Shelves (Pkg. of 12 dividers) | DC16EC |
| 18 | 457 | 36 | 914 | 60 | 1524 | 95 | 42.7 | Four Slanted Shelves One Flat Top Shelf | DC35EC |
| 18 | 457 | 36 | 914 | 70 | 1778 | 104 | 46.8 | Five Slanted Shelves | DC36EC |
| 18 | 457 | 48 | 1219 | 60 | 1524 | 112 | 50.4 | Four Slanted Shelves One Flat Top Shelf | DC55EC |
| 18 | 457 | 48 | 1219 | 70 | 1778 | 123 | 55.3 | Five Slanted Shelves | DC56EC |

Additional Shelves

Additional shelves are 18" (457mm) wide.

| Length (in.) (mm) | Approx. Pkd. Wt. (lbs.) (kg) | Cat. No. |
|-------------------|------------------------------|----------------|
| 24 | 10.5 4.7 | 1824DNC |
| 36 | 14 6.3 | 1836DNC |
| 48 | 18 8.1 | 1848DNC |

Additional Dividers

Keeps different types of merchandise separated and in order.

| Size Width/Length (in.) (mm) | Approx. Pkd. Wt. (lbs.) (kg) | Cat. No. |
|------------------------------|------------------------------|---------------|
| 4x17 100x430 | 8 3.6 | DCR17C |



Slanted Shelf Merchandiser/
Dispenser Rack
DC56EC



3KR366FC Keg Handling Rack

HD Super™ Beer Keg Handling Racks — {10.70}

Withstands the heavy load of full kegs and the repeated impact of being loaded and unloaded. Doubles storage capacity and provides a neat, orderly way to store kegs for easier inventory and stock rotation.

- Constructed of sturdy HD Super™ components, with 1.63" (41mm) diameter posts.

| Shelf Length/Height (in.) (mm) | Shelves* | Keg 1/2 Barrel Storage Capacity | Approx. Pkd. Wt. (lbs.) (kg) | Cat. No. Chrome |
|--------------------------------|----------|---------------------------------|------------------------------|-----------------|
| 42x56.13 1067x1424 | 2-D | 4 | 118 53.1 | 2KR345DC |
| 60x56.13 1524x1424 | 2-D | 6 | 147 66.1 | 2KR365DC |
| 42x56.13 1067x1424 | 1-D | 4 | 87 39.1 | KR345DC |
| 60x56.13 1524x1424 | 1-D | 6 | 104 46.8 | KR365DC |
| 42x64.13 1067x1628 | 1-D, 2-S | 2 | 121 54.4 | 3KR346FC |
| 60x64.13 1524x1628 | 1-D, 2-S | 3 | 151 67.9 | 3KR366FC |
| 42x64.13 1067x1628 | 1-D, 1-S | 4 | 112 50.4 | 2KR346MC |
| 60x64.13 1524x1628 | 1-D, 1-S | 6 | 137 61.6 | 2KR366MC |

*D = dunnage shelf; S = solid shelf; all shelves are 18" (457mm) wide. All models include foot plates for stability and easy leveling.



WC257C Cradle Shelving

Super Erecta® Cradle Wine Shelving — {10.48}

Each bottle is supported individually in a cradle formed by the wires of the shelf, so it cannot roll or bump against adjacent bottles.

- Open-wire construction keeps bottles and labels highly visible for easy reading and selection.
- Shelves, spaced 5" (127mm) apart, provide easy access to bottles for loading or removal and permit air to circulate freely around the bottles.

| Width/Length (in.) (mm) | Overall Height (in.) (mm) | Capacity (750ml bottles) | Approx. Pkd. Wt. (lbs.) (kg) | Cat. No. Chrome |
|-------------------------|---------------------------|--------------------------|------------------------------|-----------------|
| 14x36 355x914 | 74.75 1899 | 126 | 112 51 | WC237C |
| 14x36 355x914 | 86.75 2203 | 153 | 133 60 | WC238C |
| 14x48 355x1219 | 74.75 1899 | 168 | 133 60 | WC257C |
| 14x48 355x1219 | 86.75 2203 | 204 | 160 73 | WC258C |

All models include foot plates for stability and easy leveling.

Super Erecta® Bulk Storage Wine Shelving — {10.47}

Permits storage of a large quantity of wines in a limited space — an average of one case per linear foot (350mm) of shelf.

- Holds bottles at an upward slant of 10° to keep corks moist.
- Open-wire construction permits air flow, which is critical in maintaining the proper temperature.
- Units are enclosed by back and side panels which keep bottles secure and prevent accidents.
- For security from loss or pilferage, optional doors, which can be locked with a padlock, are available for the 16-case unit.

| Width/Length (in.) (mm) | Overall Height (in.) (mm) | Capacity (Cases of 750ml bottles) | Approx. Pkd. Wt. (lbs.) (kg) | Cat. No. Chrome |
|-------------------------|---------------------------|-----------------------------------|------------------------------|-----------------|
| 14x36 355x914 | 74.75 1899 | 12 | 138 63 | WB237C |
| 14x36 355x914 | 86.75 2203 | 15 | 168 76 | WB238C |
| 14x48 355x1219 | 74.75 1899 | 16 | 168 76 | WB257C |
| 14x48 355x1219 | 86.75 2203 | 20 | 204 93 | WB258C |

All models include foot plates for stability and easy leveling.



WB257C Bulk Shelving



Basic Wine Shelving Components — {10.49}

Posts with Foot Plate

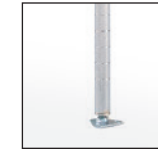

| Overall Height (in.) (mm) | Approx. Pkd. Wt. Each (lbs.) (kg) | Cat. No. |
|---------------------------|-----------------------------------|----------|
| 74.75 1899 | 4.5 2.0 | 74FPC |
| 86.75 2203 | 5.5 2.5 | 86FPC |

Wall Clamps

Give single units greater stability. Cat. No. 9984C

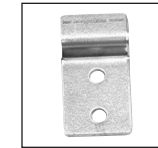

Wall Clamp

14" (355mm) Wall Mounts

Both types of wine shelves can be wall-mounted. See page 129 for 14" (355mm) direct and post-type wall mounts.

14" (355mm) Cradle Shelves

| Width/Length (in.) (mm) | Capacity (750ml bottles) | Approx. Pkd. Wt. (lbs.) (kg) | Cat. No. |
|-------------------------|--------------------------|------------------------------|----------|
| 14x36 355x914 | 9 | 7 3.2 | W1436NC |
| 14x48 355x1219 | 12 | 8.5 3.8 | W1448NC |

Enclosure Components — {10.49}

End Panels*

Two required per unit (one for each end)

| Width (in.) (mm) | Height (in.) (mm) | Use With Posts | Approx. Pkd. Wt. (lbs.) (kg) | Cat. No. |
|------------------|-------------------|----------------|------------------------------|----------|
| 13 330 | 60 1524 | 74FPC | 10.5 4.7 | EP27C |
| 13 330 | 75 1905 | 86FPC | 12.5 5.6 | EP28C |

*For end and back panels to fit properly, there must be a shelf spaced every 15" (381mm) as in the standard 15" (381mm) spacing for bulk storage wine units and 5" (127mm) spacing for cradle wine units.

Bin Components for Bulk Storage Units — {10.49}

Bin Dividers

Used to separate bottles.

| Width (in.) (mm) | Height (in.) (mm) | Approx. Pkd. Wt. (lbs.) (kg) | Cat. No. |
|------------------|-------------------|------------------------------|----------|
| 12.5 317 | 19 482 | 1.5 .67 | BD15C |

Bottle Supports

Use when bottles are to be stacked in bins. For use with 1436NC or 1448NC shelves spaced 15" (381mm) apart.

| Length (in.) (mm) | Shelf Length (in.) (mm) | Approx. Pkd. Wt. (lbs.) (kg) | Cat. No. |
|-------------------|-------------------------|------------------------------|----------|
| 35 889 | 36 914 | 1.5 .67 | BS3C |
| 47 1194 | 48 1219 | 2 .9 | BS5C |



14" (355mm) Flat Wire Shelves

| Width/Length (in.) (mm) | Approx. Pkd. Wt. (lbs.) (kg) | Cat. No. |
|-------------------------|------------------------------|----------|
| 14x36 355x914 | 9.5 4.3 | 1436NC |
| 14x48 355x1219 | 12 5.4 | 1448NC |

Back Panels*

36" units require two back panels per unit. 48" units require three back panels per unit.

| Width (in.) (mm) | Height (in.) (mm) | Use With Posts | Approx. Pkd. Wt. (lbs.) (kg) | Cat. No. |
|------------------|-------------------|----------------|------------------------------|----------|
| 14.5 368 | 60 1524 | 74FPC | 11 5.0 | BP27C |
| 14.5 368 | 75 1905 | 86FPC | 13 5.9 | BP28C |

*For end and back panels to fit properly, there must be a shelf spaced every 15" (381mm) as in the standard 15" (381mm) spacing for bulk storage wine units and 5" (127mm) spacing for cradle wine units.

Wine Shelving Accessories — {10.47} {10.48} {10.49}

Door Set (Fits only WB257C and WC257C)

| Width (in.) (mm) | Height (in.) (mm) | Fits Units | Approx. Pkd. Wt. (lbs.) (kg) | Cat. No. |
|------------------|-------------------|------------------------------------|------------------------------|----------|
| 51 1295 | 60 1524 | 48" longx74.75" high (1219x1898mm) | 42 18.9 | ED57C |

Joining Hook

Used when units are placed back to back or end to end.



| Width (in.) (mm) | Depth (in.) (mm) | Height (in.) (mm) | Cat. No. |
|------------------|------------------|-------------------|----------|
| .66 15.2 | 1.63 40.6 | 2.25 57 | JH2C |



Hold, transport & organize.



FLMB2

THE MINI BAR RESTOCKING CART

MANEUVERABLE:

- Four 5" (127mm) diameter casters (2 directional, 2 with brake), provide easy maneuverability, control and stability.

STORAGE CAPACITY:

- Recessed side storage areas hold three (3) tilt-out bins on the right and one (1) tilt-out bin and wastebasket on the left side.
- A total of 27" (686mm) of drawer space provides ample room for beverage cans, juice and water bottles.

SECURED SUPPLIES:

- Key lock on right side protects valuable supplies in all drawers and right side tilt-out bins from loss or pilferage.

DURABLE CONSTRUCTION:

- Sturdy polymer construction is extremely easy to clean, and is resistant to cracking, peeling or chipping.
- Full extension drawers have self-closing ball bearing slides to provide easy access to all supplies.
- Spacious work surface provides a smooth writing surface or ample space for prep work.

SANITARY:

- Smooth, rounded corners and seamless cart surfaces simplify cleaning.

MICROBAN® ANTIMICROBIAL PRODUCT PROTECTION:

- Advanced polymer construction has built-in Microban® Antimicrobial Product Protection which inhibits the growth of bacteria, mold, mildew, and fungi that cause odors, stains, and product degradation.

Mini Bar Restocking Carts

| Width/Depth/Height (in.) | Width/Depth/Height (mm) | Weight (lbs.) (kg) | Drawers | Wastebasket | Tilt-out Bins | Drawer Divider Kit | Cat. No. |
|--------------------------|-------------------------|--------------------|---|-------------|-----------------------|--------------------|--------------|
| 33x22x42 | 838x559x1067 | 125 57 | (3) 6" (152mm) (1) 9" (229mm) | X | 3 (Right) 1 (Left) | 1* | FLMB1 |
| 33x22x42 | 838x559x1067 | 125 57 | (1) 3" (76mm) (1) 6" (152mm) (2) 9" (229mm) | X | 3 (Right) 1 (Left) | 1* | FLMB2 |

*Divider Kit is for one 6" (152mm) or one 9" (229mm) drawer.

Accessories

| Description | Model |
|--------------------------------------|--------------|
| 3" (76mm) Drawer Divider Kit | FL113 |
| 6"/9" (152/229mm) Drawer Divider Kit | FL116 |

*Touch Pad Electronic Locking/Unlocking option is available. Please contact your local Metro Representative.



Convertible Wire Truck — {31.12}

Versatile construction allows folding shelves to be positioned horizontally or vertically to configure 3 different truck positions.

- Brake Lock/Swivel Lock combination casters increase flexibility.
- Open-wire design maximizes air circulation and visibility.

Perfect for:
Hospitality or Healthcare Linens

| Shelf Size Width/Length (in.) (mm) | Height (in.) (mm) | Description | Approx. Pkd. Wt. (lbs.) (kg) | Cat. No. |
|--|-------------------|----------------------------|------------------------------|------------------|
| Standard-Duty — Chrome | | | | |
| 24x48 610x1219 | 70 1778 | CLT with 3-sided top frame | 180 82 | CLTS2448C |
| 24x60 610x1524 | 70 1778 | CLT with 3-sided top frame | 200 91 | CLTS2460C |
| Standard-Duty — Stainless Steel | | | | |
| 24x60 610x1524 | 70 1778 | CLT with 3-sided top frame | 169 77 | CLT2460S |
| Heavy-Duty — Chrome | | | | |
| 24x60 610x1524 | 70 1778 | CLT with 3-sided top frame | 241 109 | CLTH2460C |

Material: Chrome Models: Chrome-plated steel dolly and aluminum tubes. Stainless Steel: Stainless steel dolly and aluminum tubes.
Note 1: Casters on above units consist of two 6P and one pair BL6P, 8P and BL8P available on special order.
Note 2: Before employing any of various cart-washing systems, please contact InterMetro Industries Corporation or your Metro representative for special recommendations on casters and for cleaning instructions.

Accessories

| Description | Model |
|-------------|---------------|
| Card Holder | CLCHC |
| Push Handle | PH24NC |



Shelves Flip Down To Contain Dirty Linen Bags.

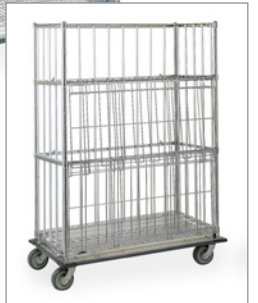

CLTH2460C

MetroTrux™ Polymer Truck — {31.43}

Units are constructed of an advanced polymer material with molded contours that provide a ruggedized body to endure the toughest daily use. Its contemporary aesthetic provides elegance to fit into any décor.

| Height (in.) (mm) | Description | Approx. Pkd. Wt. (lbs.) (kg) | Cat. No. |
|-------------------|---|------------------------------|----------------------|
| 72 1829 | Trux, Convertible, 2 SS Shelves, 4 Swivel Casters | 152 69 | TXPA-CLT48S |
| 72 1829 | Trux, Convertible, 2 SS Shelves, 2 Swivel/2 Rigid Casters | 152 69 | TXPB-CLT48S |
| 72 1829 | Trux, Bulk with 4 Swivel Casters | 128 58 | TXPA-BLK48 |
| 72 1829 | Trux, Bulk with 2 Swivel/2 Rigid Casters | 128 58 | TXPB-BLK48 |
| 73.34 1863 | Trux, Bulk with 4 Swivel Casters, with Closures | 148 67 | TXPA-BLK48SEC |
| 73.34 1863 | Trux, Bulk with 2 Swivel/2 Rigid Casters, with Closures | 148 67 | TXPB-BLK48SEC |
| | *Trux, Cart Cover, Uncoated, Velcro Close, Navy Blue | 5 2 | TX-48CVUCNB |

All MetroTrux units measure 29.5" W x 48" L (749 x 1219mm)
Drain holes and routing slip clips are standard on all MetroTrux units.



Convertible Trux



*Cart covers are a darker blue than the truck color. Color block is an approximate shade of Navy Blue color.



Security Bulk Trux



Bulk Trux



Hello Dolly.

DELIVERING ADJUSTABILITY, VARIETY & PROTECTION



PCD11A

Adjustable towers offer maximum versatility.

Recessed handles for better maneuverability and efficient storage.

One-piece, sturdy polymer construction is extremely durable and easy to clean.

Standard 5" (127mm) neoprene swivel casters (two with brakes) for easy maneuverability.

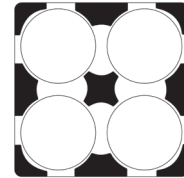
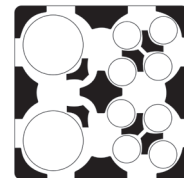

Plate sizes 9.63" – 11.75"
4 Columns (60 per)
*Capacity 240



4.25" – 4.63"
8 Columns (40 per)
7.5" – 9.5"
2 Columns (60 per)

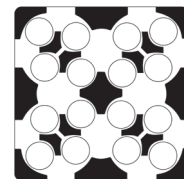

Plate sizes 4.25" – 4.63"
16 Columns (40 per)
*Capacity 640

*Varies on china shape & thickness.
Usable column height is 20"

EFFICIENCY, STYLE AGILITY AT YOUR FINGERTIPS

- Built-in Microban® Antimicrobial Product Protection.
- "Fixed Position" PCD's are designed to hold 5", 7", 8", 9", 11" or 12" plates securely in place.
- Versatile design allows transport of glass racks.



PCD9

PCD9 shown with glass rack (Glass rack not included.)

SIDE-LOAD DISH & TRAY CARTS

- Perfect for holding a variety of different sized dishes, odd-shaped platters and trays.
- New recessed handles increase maneuverability and make transport effortless.
- One-piece, sturdy polymer construction with built-in drain holes promote cleanability.



Model DSD11 shown with optional divider accessory A110



Model SSD16 shown with optional divider accessory A110



Adjustable Polymer "Poker Chip" Dish Dollies — {16.21}

(with *Microban® Antimicrobial Product Protection)

Unique design utilizing adjustable, removable towers provides total flexibility and maximum loading density. Two-handed access to all dish columns means easy retrieval and reduced chance of dish breakage. Handle dish sizes from 4.25" (108mm) to 11.75" (298mm) in diameter.

- High-density polymer shell is resistant to cracking, peeling, and chipping. Smooth surfaces prevent snags.
- Square compact design allows for maximum space utilization and stores conveniently under counters, out of the way.
- Standard 5" (127mm) neoprene swivel casters (two with brakes) for easy maneuverability.
- Vinyl dust cover included.
- NSF listed.



PCD11A

Metro Tip:

Adjustable Poker Chip Dish Dollies are perfect for carrying multiple-size dishes, or if you're not sure of the sizes you will be using.

| Width/Height/Depth | | Approx. Pkd. Wt. | | Cat. No. |
|--------------------|-------------|------------------|------|----------|
| (in.) | (mm) | (lbs.) | (kg) | |
| 26.63x31.94x26.63 | 676x812x676 | 65 | 30 | PCD11A |

Protective cover is standard.

Accessories

| Description | Model |
|-----------------------|---------|
| 4 Additional Dividers | AD11A |
| Additional Cover | PCDV11A |

Polymer "Poker Chip" Dish Dollies — {16.23}

(with *Microban® Antimicrobial Product Protection)

Two-handed dish access for easy retrieval and less chance of breakage.

- Chip-resistant polymer shell has snag-proof surface.
- Space efficient square design stores out of the way under counters.
- Standard 5" (127mm) neoprene swivel casters (two with brakes) provides easy maneuverability.
- Vinyl dust cover included.
- NSF listed.

| Width/Height/Depth | | No. of Dish Columns | Approx. Dish Capacity Per Column* | Total Approx. Dish Capacity* | Maximum Dish Size (in.) | Approx. Pkd. Wt. (lbs.) | Approx. Pkd. Wt. (kg) | Cat. No. |
|--|-------------|---------------------|-----------------------------------|------------------------------|-------------------------|-------------------------|-----------------------|----------|
| (in.) | (mm) | | | | | | | |
| 24 ¹ / ₁₆ x 31 ¹⁵ / ₁₆ x 24 ¹ / ₁₆ | 612x812x612 | 9 | 40 | 360-540 | 5.63 143 | 61 | 27 | PCD5 |
| 27 ¹⁵ / ₁₆ x 31 ¹⁵ / ₁₆ x 27 ¹⁵ / ₁₆ | 707x812x707 | 9 | 40-60 | 360-540 | 6.88 175 | 72 | 32 | PCD7 |
| 21 ¹ / ₂ x 31 ¹⁵ / ₁₆ x 21 ¹ / ₂ | 547x812x547 | 4 | 60 | 240 | 8.25 210 | 51 | 22 | PCD8 |
| 23 ¹⁵ / ₁₆ x 31 ¹⁵ / ₁₆ x 23 ¹⁵ / ₁₆ | 609x812x609 | 4 | 60 | 240 | 9.5 241 | 56 | 25 | PCD9 |
| 26 ¹⁵ / ₁₆ x 31 ¹⁵ / ₁₆ x 26 ¹⁵ / ₁₆ | 685x812x685 | 4 | 60 | 240 | 11 279 | 65 | 29 | PCD11 |
| 30 ¹ / ₂ x 31 ¹⁵ / ₁₆ x 30 ¹ / ₂ | 766x812x766 | 4 | 60 | 240 | 12.63 321 | 70 | 32 | PCD12 |

*Loading capacity dependent upon china shapes and thickness. Protective cover is standard. For additional covers, see accessories below.

Accessories

| Description | Model |
|----------------------------|--------|
| Additional Cover for PCD5 | PCDV5 |
| Additional Cover for PCD7 | PCDV7 |
| Additional Cover for PCD8 | PCDV8 |
| Additional Cover for PCD9 | PCDV9 |
| Additional Cover for PCD11 | PCDV11 |
| Additional Cover for PCD12 | PCDV12 |

✓ Indicates antimicrobial product.

Metro Fact:

Poker Chip Dish Dollies are enhanced with built-in Microban® antimicrobial product protection, which protects the product from bacteria, mold, mildew and fungi that cause odors, stains and product degradation.



PCD9

Metro Tip:

Two-handed access to all dish columns provides for safer loading and unloading. Dollies have four swivel casters for maneuvering in and out of tight quarters.

TRAY CARTS/WARE HANDLING



SSD16 shown with optional Divider Accessory A110



DSD11 shown with optional Divider Accessory A110



D2020N



CBH2121C Dish Rack Dolly (Racks not included)

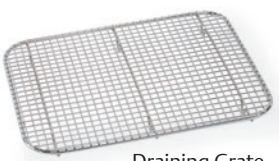

Draining Grate

Side-Load Polymer Dish and Tray Carts — {16.32}

(with *Microban® Antimicrobial Product Protection)

Adjustable dividers accommodate a variety of different-sized dishes and trays.

- Side-load dish and tray carts come in single and double-sided models.
- Perfect for holding a variety of different sized dishes, odd-shaped platters and trays.
- Corrosion-free polymer construction makes surfaces smooth and easy to clean.
- Vinyl dust/splash cover included to protect stored contents.
- Standard 5" (127mm) neoprene swivel casters (two with brakes) for easy maneuverability.

| Overall Width/Height/Depth (in.) (mm) | Approx. Dish Capacity Per Column** | Approx. Tray Capacity Per Column** | Approx. Pkd. Wt. (lbs.) (kg) | Cat. No. |
|---------------------------------------|------------------------------------|------------------------------------|------------------------------|--------------|
| 39.63x32.94x21.63 1007x837x550 | 60 | 80 | 82 36 | SSD16 |
| 39.63x31.94x29.06 1007x812x739 | 60 | 80 | 100 45 | DSD11 |

**Loading capacity dependent upon chain and tray shapes/thickness. Protective cover is standard. For additional covers, see accessories below.

Accessories

| Description | Model |
|--|---------------|
| Divider Assembly (1 rod and 2 dividers) | A110 |
| Additional Divider | A115 |
| Additional Cover for Single Side-Load Dish and Tray Cart | SSDV16 |
| Additional Cover for Double Side-Load Dish and Tray Cart | DSDV11 |

Dish Rack Dollies — {16.14}

Lightweight aluminum, but built for heavy service.

- 5" (127mm) non-marking swivel casters.
- Non-marking corner bumpers.
- Tubular steel handle optional on D2020N.

| Dimensions (in.) (mm) | Height (in.) (mm) | Type | Approx. Pkd. Wt. (lbs.) (kg) | Cat. No. |
|-----------------------|-------------------|----------------|------------------------------|----------------|
| 21.5x21.5 546x546 | 6.13 154 | Without Handle | 13.63 345 | D2020N |
| 21.5x21.5 546x546 | 33.36 843 | With Handle | 15.75 400 | DH2020N |
| | | Handle | | H2020C |

Dollies under 21.5" sq. (546mm) made to order.



D2121C

Cup/Glass Rack Dollies — {16.14}

Store cup/glass racks at a convenient, easy-access height.

| Overall Dimensions Width/Length (in.) (mm) | Overall Height (in.) (mm) | Type | Approx. Pkd. Wt. (lbs.) (kg) | Cat. No. |
|--|---------------------------|--------------------------------|------------------------------|-----------------|
| 20.88x20.88 530x530 | 12.13 307 | Without Bumpers and Handle | 28 12.6 | D2121C |
| 20.88x23.88 530x607 | 36.63 929 | With Handle | 33 14.8 | DH2121C |
| 23.36x23.36 594x594 | 12.13 307 | With Corner Bumpers | 29 13 | CB2121C |
| 23.36x25 594x635 | 36.63 929 | With Corner Bumpers and Handle | 34 15.3 | CBH2121C |

Draining Grate

| Outside Dimensions Width/Length (in.) (mm) | 12 Pieces Per Package Approx. Pkd. Wt. (lbs.) (kg) | Cat. No. |
|--|--|----------------|
| 8.25x10.5 209x266 | 11 4.9 | 6511DR |
| 10.13x18 256x457 | 22 9.9 | 6517DR* |
| 16.5x24.5 419x622 | 28 12.6 | 6518DR† |

*Fits 12"x20" (305x508mm) pan (#200).
†Fits 18"x26" (457x660mm) baking sheet.

Indicates antimicrobial product.

TERMS AND CONDITIONS (SUBJECT TO CHANGE)

Standard Terms and Conditions of Sale

These Terms and Conditions, the attendant quotation or acknowledgment, and all documents incorporated by specific reference therein will be the complete and exclusive statement of the terms of the agreement governing the sale of goods ("Goods") by

InterMetro Industries Corporation and its divisions ("Seller") to Customer ("Buyer"). Buyer's acceptance of the Goods will manifest Buyer's assent to these terms and conditions. If these terms and conditions differ in any way from the terms and conditions of Buyer's order, or other documentation, this document will be construed as a counteroffer and will not be deemed an acceptance of Buyer's terms and conditions which conflict herewith, and to the extent there is any conflict between the terms and conditions herein and any purchase order or other document from the Buyer, the terms and conditions herein shall govern and prevail.

1. Prices:

Unless otherwise specified in writing by Seller, Seller's price for the Goods shall remain in effect for thirty (30) days after the date of Seller's quotation or acknowledgment of Buyer's order for the Goods, whichever occurs first, provided an unconditional, complete authorization for the immediate shipment of the Goods is received and accepted by Seller within such time period. If such authorization is not received by Seller within such thirty (30) day period, Seller shall have the right to change the price for the Goods to Seller's price for the Goods at the time of shipment.

2. Taxes:

Any tax or governmental charge or increase in same hereafter becoming effective increasing the cost to Seller of producing, selling or delivering the Goods or of procuring material used therein, and any tax now in effect or increase in same payable by the Seller because of the manufacture, sale or delivery of the Goods, may at Seller's option, be added to the price.

3. Terms and Payment:

Subject to the approval of Seller's Credit Department, terms are 1% ten (10) days net thirty (30) days from date of Seller's invoice in

U.S. currency. Payment shall be made in full without set-off, counterclaim or withholding of any kind. Freight, handling and other service charges are not subject to discount. If any

payment owed to Seller is not paid when due, it shall bear interest at a rate to be determined by Seller, which shall not exceed the maximum rate permitted by law, from the date on which it is due until it is paid. Seller shall have the right, among other remedies, either to terminate the agreement or to suspend further performance under this and/or other agreements with Buyer. Buyer shall be liable for all expenses, including attorneys' fees, relating to the collection of past due amounts.

Forms of payment accepted by InterMetro include: Cash, Check, Wire Transfer, Automated Clearing House Network, and Credit Card. Credit Card payments will be subject to a 3% charge.

Minimum Order, Returns, Cancellations, Changes and Configured Products:

Orders under \$300.00 net, will be charged a handling fee of \$39.00 plus actual freight costs. (All amounts in U.S. currency.)

Written approval is required from the Seller's factory to return merchandise. All merchandise must be returned within forty-five (45) days from the invoice date and be returned in original, unopened, and resalable packaging. A Return Merchandise Authorization (RMA) must be obtained through Seller's customer service department prior to returning the product. All costs of returned items, including shipping and insurance shall be the responsibility of the Buyer.

1. Minimum return value - \$200.00 net.
2. Restocking charge - 15% (\$50.00 minimum).

Exceptions - Special orders of cut posts, made to order dollies, cart covers, Designer Color product, Configured Products (defined as C5 Heated Cabinets, Lifeline, Flexline, Starsys, MetroBasix Pus, MetroBasix, Lionville Fixtures, Lionville iPoint Carts, and Lionville Med carts), and custom or made-to-order are not returnable. Accessories for Configured Products are returnable at the discretion of Seller.

All order change requests must be requested through Seller's customer service. Changes/cancellations, for exception items listed above, requested within seven (7) workdays of the scheduled ship date that will impact order production will incur, at minimum, a 20% Change/Cancellation Fee, up to the full order value, depending on the percentage of the order completed. Customer service will relay percentage of order completed along with the Change/Cancellation Fee amount. Prior to Seller accepting the change, a revised purchase order (including associated Fee) is required. Orders for C5 cabinets with an "A" suffix are non-cancellable.

Buyer may request changes or additions to the Goods consistent with Seller's specifications and criteria. In the event such changes or additions are accepted by Seller, Seller may revise the price and delivery schedule.

Seller reserves the right to change designs and specifications for the Goods without prior notice to Buyer, except with respect to Goods being made-to-order for Buyer.

4. Shipment and Delivery:

Shipments are made FOB Seller's shipping point. Seller reserves the right to split orders based on the FOB Shipping Point. Order consolidation is available for an additional charge. Buyer should contact customer service for more information. Any claims for shortages or damages suffered in transit shall be submitted by the Buyer directly to the carrier. While Seller will use all reasonable commercial efforts to maintain the delivery date acknowledged or quoted by Seller, all shipping dates are approximate. Seller reserves the right to make partial shipments and to segregate "specials" and made-to-order Goods from normal stock Goods. Seller shall not be bound to tender delivery of any Goods for which Buyer has not provided shipping instructions.

5. Limited Warranty:

(a) Subject to the limitations of Section 6, Seller warrants that the Goods will be free from defects in material and workmanship under normal use, service and maintenance for a period of one year (unless otherwise specified by Seller in writing) from the date of shipment of the Goods by Seller.

THIS IS THE SOLE AND EXCLUSIVE WARRANTY GIVEN BY SELLER WITH RESPECT TO THE GOODS AND IS IN LIEU OF AND EXCLUDES ALL OTHER WARRANTIES, EXPRESS OR IMPLIED, ARISING BY OPERATION OF LAW OR OTHERWISE, INCLUDING WITHOUT LIMITATION, MERCHANTABILITY OR FITNESS FOR A PARTICULAR PURPOSE WHETHER OR NOT THE PURPOSE OR USE HAS BEEN DISCLOSED TO SELLER IN SPECIFICATIONS, DRAWINGS OR OTHERWISE, AND WHETHER OR NOT SELLER'S PRODUCTS ARE SPECIFICALLY DESIGNED AND/OR MANUFACTURED BY SELLER FOR BUYER'S USE OR PURPOSE.

This warranty does not extend to any losses or damages due to misuse, accident, abuse, neglect, normal wear and tear, unauthorized modification or alteration, use beyond rated capacity, or improper installation, maintenance



or application. To the extent that Buyer or its agents has supplied specifications, information, representation of operating conditions or other data to Seller in the selection or design of the Goods and the preparation of Seller's quotation, and in the event that actual operating conditions or other conditions differ from those represented by Buyer, the warranties or other provisions contained herein which are affected by such conditions shall be null and void. If, within thirty (30) days after Buyer's discovery of any warranty defects within the warranty period, Buyer notifies Seller thereof in writing, Seller shall, at its option, repair or replace F.O.B. point of manufacture, or refund the purchase price for that portion of the Goods found by Seller to be defective. Failure by Buyer to give such written notice within the applicable time period shall be deemed an absolute and unconditional waiver of Buyer's claim for such defects. Goods repaired or replaced during the warranty period shall be covered by the foregoing warranty for the remainder of the original warranty period or ninety (90) days, whichever is longer. Buyer assumes all other responsibility for any loss, damage, or injury to persons or property arising out of, connected with, or resulting from the use of Goods, either alone or in combination with other products/ components.

(b) All batteries sold by Seller to Buyer hereunder receive the Goods warranty under Sections 5 and 6 with a warranty period of one year from the warranty start date. Battery adjustments will be prorated over a one year period.

(c) Seller has no obligation under the warranties provided in Sections 5 and 6 to correct any software programming error(s) that do not significantly adversely affect the use of the Goods; however, such programming error corrections shall be made available from time to time to those Buyers purchasing applicable contract maintenance services from the Seller.

(d) SECTIONS 5 AND 6 APPLY TO ANY ENTITY OR PERSON WHO MAY BUY, ACQUIRE OR USE SELLER'S GOODS, INCLUDING ANY ENTITY OR PERSON WHICH BUYS THE GOODS FROM SELLER'S DISTRIBUTOR AND SUCH ENTITY OR PERSON SHALL BE BOUND BY THE LIMITATIONS THEREIN.

6. Limitation of Remedy and Liability:

THE SOLE AND EXCLUSIVE REMEDY FOR BREACH OF ANY WARRANTY HEREUNDER (OTHER THAN THE WARRANTY PROVIDED UNDER SECTION 11) SHALL BE LIMITED TO REPAIR, REPLACEMENT OR REFUND OF THE PURCHASE PRICE OF THE AFFECTED GOODS. SELLER SHALL NOT BE LIABLE

FOR DAMAGES CAUSED BY DELAY IN PERFORMANCE, AND IN NO EVENT, REGARDLESS OF THE FORM OF THE CLAIM OR CAUSE OF ACTION (WHETHER BASED IN CONTRACT, INFRINGEMENT, NEGLIGENCE, STRICT LIABILITY, OTHER TORT OR OTHERWISE), SHALL SELLER'S LIABILITY TO BUYER AND/ OR ITS CUSTOMERS EXCEED THE PRICE PAID BY THE BUYER FOR THE SPECIFIC GOODS PROVIDED BY SELLER GIVING RISE TO THE CLAIM OR CAUSE OF ACTION. BUYER AGREES THAT IN NO EVENT SHALL SELLER'S LIABILITY TO BUYER AND/OR ITS CUSTOMERS EXTEND TO OR INCLUDE INCIDENTAL, CONSEQUENTIAL OR PUNITIVE DAMAGES. THE TERM "CONSEQUENTIAL DAMAGES" SHALL INCLUDE, BUT NOT BE LIMITED TO, LOSS OF ANTICIPATED PROFITS, LOSS OF USE, LOSS OF REVENUE, COST OF CAPITAL AND DAMAGE OR LOSS OF OTHER PROPERTY OR EQUIPMENT.

It is expressly understood that any technical advice furnished by Seller with respect to the use of the Goods is given without charge, and Seller assumes no obligation or liability for the advice given, or results obtained; all such advice being given and accepted at Buyer's risk.

7. Excuse of Performance:

Seller shall not be liable for delays in performance or for non-performance due to acts of God; acts of Buyer; war, riot, fire, flood, power surges, other severe weather, sabotage, or epidemics; strikes or labor disturbances; governmental requests, restrictions, laws, regulations, orders or actions; unavailability of or delays in transportation; default of suppliers; or unforeseen circumstances or any events or causes beyond Seller's reasonable control. Deliveries may be suspended for an appropriate period of time as a result of the foregoing. If Seller determines that its ability to supply the total demand for the Goods is hindered, limited or made impracticable due to causes addressed in this Section 7, Seller may allocate its available supply of the Goods or such material (without obligation to acquire other supplies of any such Goods or such materials) among itself and its purchasers on such basis as Seller determines to be equitable without liability for any failure of performance which may result therefrom. Deliveries suspended or not made by reason of this Section 7 may be canceled by Seller upon notice to Buyer without liability, but the balance of the agreement shall otherwise remain unaffected.

8. Software:

Notwithstanding any other provision herein to the contrary, Seller or applicable third party licensor to Seller shall retain all rights of ownership and title in its respective Software, including without limitation all rights of ownership and title in its respective copies of such Software. Except as otherwise provided herein, Buyer is hereby granted a nonexclusive, non-transferable royalty free license to use the Software incorporated into the Goods solely for purposes of Buyer properly utilizing such Goods purchased from Seller. All other Software shall be furnished to, and used by Buyer only after execution of Seller's (or the licensor's) applicable standard license agreement.

9. Tooling:

Tool, die, and pattern charges, if any, are in addition to the price of the Goods and are due and payable upon completion of the tooling. All such tools, dies and patterns shall be and remain the property of Seller. Charges for tools, dies, and patterns do not convey to Buyer title, ownership interests in, or rights to possession or removal, nor prevent their use by Seller for other purchasers, except as otherwise expressly provided by Seller and Buyer in writing with reference to this provision.

10. Assignment:

Buyer shall not assign its rights or delegate its duties hereunder or any interest therein or any rights hereunder without the prior written consent of the Seller, and any such assignment, without such consent, shall be void.

11. Patents and Copyrights:

Subject to Section 6, Seller warrants that the Goods sold, except as are made specifically for Buyer according to Buyer's specifications, do not infringe any valid U.S. patent or copyright in existence as of the date of delivery. This warranty is given upon the condition that Buyer promptly notify Seller of any claim or suit involving Buyer in which such infringement is alleged, and that Buyer cooperate fully with Seller and permit Seller to control completely the defense or compromise of any such allegation of infringement. Seller's warranty as to use only applies to infringements arising solely out of the inherent operation (1) of such Goods, or (2) of any combination of Goods in a system designed by Seller. In the event such Goods, singularly or in combination, are held to infringe a U.S.



patent or copyright in such suit, and the use of such Goods is enjoined, or in the case of a compromise by Seller, Seller shall have the right at its option and expense to: (i) procure for Buyer the right to continue using such Goods; or (ii) replace them with non-infringing Goods; or (iii) modify same to become non-infringing; or (iv) grant Buyer a credit for the depreciated value of such Goods and accept return of them.

All information (including but not limited to pricing, descriptions, specifications and drawings) provided by Seller in email, literature, website, quotations, order acknowledgements or other is proprietary in nature and deemed CONFIDENTIAL intended for use solely by the designated party.

Seller's name, logo, designs, drawings, trademarks and other intellectual property remains the property of Seller and may not be disclosed, reproduced, or used without its prior written consent.

12. General Provisions:

These terms and conditions supersede all other communications, negotiations and prior oral or written statements regarding the subject matter of these terms and conditions. No change, modification, rescission, discharge, abandonment or waiver of these terms and conditions shall be binding upon the Seller unless made in writing and signed on its behalf by a duly authorized representative of Seller. No conditions, usage of trade, course of dealing or performance, understanding or agreement purporting to modify, vary, explain, or supplement these terms and conditions shall be binding unless hereafter made in writing and signed by the party to be bound, and no modification or additional terms shall be applicable to this agreement by Seller's receipt, acknowledgment, or acceptance of purchase orders, shipping instruction forms, or other documentation containing terms at variance with or in addition to those set forth herein. Any such modifications or additional terms are specifically rejected by Seller. No waiver by either party with respect to any breach or default or of any right or remedy, and no course of dealing, shall be deemed to constitute a continuing waiver of any other breach or default or of any other right or remedy, unless such waiver be expressed in writing and signed by the party to be bound. All typographical or clerical errors made by Seller in any quotation, acknowledgment or publication are subject to correction.

The validity, performance, and all other matters relating to the interpretation and effect of this agreement shall be governed by the law of the Commonwealth of Pennsylvania. Buyer

and Seller agree that the proper venue for all actions arising in connection herewith shall be only in the Court of Common Pleas of Luzerne County, Pennsylvania or the United States District Court for the Middle District of Pennsylvania, and the parties agree to submit to such exclusive jurisdiction. No action, regardless of form, arising out of transactions relating to this agreement or underlying agreement, may be brought by either party more than two (2) years after the cause of action has accrued. The United Nations Convention for the International Sales of Goods shall not apply to this agreement.

Buyer agrees that all applicable import, export control and sanctions laws, regulations, orders and requirements, as they may be amended from time to time, including without limitation those of the United States, the European Union and the jurisdictions in which Seller and Buyer are established or from which items may be supplied, and the requirements of any licenses, authorizations, general licenses or license exceptions relating thereto will apply to its receipt and use of hardware, software, services and technology. Buyer agrees furthermore that it shall not engage in any activity that would expose Seller or any of its affiliates to a risk of penalties under laws and regulations of any relevant jurisdiction prohibiting improper payments, including but not limited to bribes, to officials of any government or of any agency, instrumentality or political subdivision thereof, to political parties or political party officials or candidates for public office, or to any employee of any customer or supplier. Buyer agrees to comply with all appropriate legal, ethical and compliance requirements. To the extent applicable, and except to the extent otherwise required by applicable law, Seller shall have no responsibility for the collection, treatment, recovery or disposal of (i) the Goods or any part thereof when they are deemed by law to be 'waste' or (ii) any items for which the Goods or any part thereof are replacements. If Seller is required by applicable law, including waste electrical and electronic equipment legislation, European Directive 2002/96/EC (WEEE) and related legislation in EU Member States, to dispose of 'waste' Goods or any part thereof, Buyer shall, unless prohibited by applicable law, pay Seller, in addition to the Contract Price, either (i) Seller's standard charge for disposing of such Goods or (ii) if Seller does not have such a standard charge, Seller's costs (including all handling, transportation and disposal costs and a reasonable mark-up for overhead) incurred in disposing of such Goods. GOODS AND SERVICES PROVIDED HEREUNDER ARE NOT SOLD OR INTENDED FOR USE IN ANY NUCLEAR OR NUCLEAR RELATED APPLICATIONS. Buyer (i) accepts Goods and Services in accordance

with the foregoing restriction, (ii) agrees to communicate such restriction in writing to any and all subsequent purchasers or users and (iii) agrees to defend, indemnify and hold harmless Seller and Seller's Affiliates from any and all claims, losses, liabilities, suits, judgments and damages, including incidental and consequential damages, arising from use of Goods and Services in any nuclear or nuclear related applications, whether the cause of action be based in tort, contract or otherwise, including allegations that the Seller's liability is based on negligence or strict liability.

All purchases made by Buyer from Seller are subject to Seller's Warranty Remedy and Return Policy.



LEARN MORE

fesmag.com/ksm



ENTER NOW

2022 KITCHEN STORAGE

MAKEOVER

WINNER HALL OF FAME

Fort William Henry Resort



2018 KITCHEN STORAGE MAKEOVER

Columbus JCC



2019 KITCHEN STORAGE MAKEOVER

Ynot Italian Restaurant



2020 KITCHEN STORAGE MAKEOVER

Harborcreek Youth Services



2021 KITCHEN STORAGE MAKEOVER K12 SCHOOL EDITION

PERFECT FOR:
Restaurants
Schools
Groceraurants
C-Stores
Hospitality

Foodservice equipment & supplies.

SPONSORED EXCLUSIVELY BY



Cabinets

- C5 180-211
- Delivery/Storage 229
- Heated Banquet 222-228
- Refrigerated 218-221
- Transport 212-217

Carriers

- Mightylite 174-177

Carts

- Basket 151, 250
- Breakfast 160
- Bussing 148-149
- Dish & Tray 258
- Linen 255
- Mini Bar Restocking 254
- Online Ordering 245
- Slanted Shelf 56
- Stem Caster 20, 44, 54

Carts Utility

- Accessories 149, 151
- Deep Ledge 151
- MetroMax i 21
- MetroMax Q 21
- myCart 148-149
- Wire: Heavy Duty 153
- Wire: Standard Duty 152

Casters

- Antimicrobial 19, 59
- HD Super 78
- Decorative 58
- Plate 61
- Polymer 19, 59
- Stainless Steel 19, 59
- Stem Casters 19, 59

Dollies

- Cup/Glass Rack 258
- Dish 256-258
- Shelving Truck 55, 60

Hangers

- Extension Display 71
- Garment Tube 70
- Rail 71
- Swing 71

Housekeeping

- Linen Trucks & Carts 255
- Mini Bar Restocking Cart 254
- Transfer Exchange 22, 45

Posts

- Designer 50
- HD Super 78
- MetroMax 14, 16
- qwikSLOT 81, 83
- Super Erecta SiteSelect 37, 42, 49-50

Racks

- Beer Keg 252
- Can 28, 167
- Drying 30-33
- Dunnage 154-155
- Platform 251
- Pot & Pan 55
- Slanted Shelf Merchandising 56, 251

Racks, Mobile Pan & Tray

- Adjustable 230
- End Load 230-233
- Oval Trays 232
- Portable Wire Prep 233
- Roll In 232
- Side Load 230-233
- Wire Bun Pan 233

Shelving

- Basket 84-89, 250
- Cantilever 51, 79
- Convenience Pack 37, 51
- Designer 50
- Drop Mat 82-83
- Dunnage 12, 51, 79, 155

- Erecta 77
- Heated 170-173
- HD Super 78-79
- Hi-Rise 111
- MetroMax i 12
- MetroMax 4 14
- MetroMax Q 16
- qwikSLOT 80-81
- Seismic 112-117
- Security 96-99
- SmartLever 134-139
- Super Erecta Solid 74
- Super Erecta Wire 48
- Super Adjustable Super Erecta 42
- Wine 252-253

Starter & Add-On Units

- MetroMax i 13
- MetroMax 4 15
- MetroMax Q 17
- SmartLever 139
- Super Adjustable Super Erecta 43
- Super Erecta Pro 37-38
- Super Erecta 52-53

Shelving Accessories

- Baskets 29, 70
- Bins 90-91
- Cart Covers 72
- Color Shelf Markers 27, 39, 68
- Dividers 24-25, 64-65, 76-77, 83
- Enclosure Panels 26, 67
- Foot Plates 12, 14, 63, 79
- Glides 63
- Handles 18, 62, 153
- Hooks 71, 126
- Joining Clamps 76
- Keyboard Tray 73, 144
- Label Holders 27, 39, 68, 85, 89

PRODUCT INDEX

- Ledges 25, 39, 66, 76
- Leveling Feet 63
- Post Clamps 12, 14, 63, 79
- Rods & Tabs 65, 76
- Shelf Inlays 70
- Shelf Markers 27, 39, 68
- Slides 28, 69, 76
- Split Sleeves 63, 78
- Three-Sided Frames 29, 66
- Totes 92-93
- Tow Bar Assembly 63

Thermal

- Cabinets 180-228
- Metro2Go 172-173
- Mightylite 174-177
- Heated Insert 176
- Heated Shelving 170-171

Track Shelving

- Floor Track 100, 102-103
- Overhead Track 101, 104-109

Wall Shelving

- Brackets 128-129
- Erecta Shelf 130
- MetroMax i 130
- SmartWall 120-127
- Super Erecta Shelf 128-129

Ware Handling

- Drying Racks 30-33
- Draining Grate 258
- Poker Chip Dish Dollies 256-257
- Side-Load Dish & Tray Carts 258

WorkStations

- PrepMate 158-159
- SmartLever 134-139
- SmartStations 160-167

Work Tables & Accessories

- 140-145



INNUMERABLE OPTIONS

No matter the application or your need Metro has a solution. We provide the largest line of high-productivity shelving, cabinets, carts and accessories in the world.



IMAGINATIVE SOLUTIONS

What's the job to be done? That's what we ask every day. Our product development teams study the customers and create innovative solutions that boost productivity and efficiency for all applications.



PREMIUM BRAND

For over 90 years we've developed the most advanced storage & productivity solutions in the world utilizing the highest quality materials. Our products are tested & engineered to withstand the most stringent safety and durability standards...and we guarantee it.



NORTH AMERICAN MANUFACTURING

Having control of our supply chain is at the core of providing an exceptional customer experience. It allows for reduced shipping, shorter lead times, environmental responsibility and a higher standard for safety & quality.



ULTIMATE VALUE

Within every Metro product comes more value than any other brand. We provide better service, more options, and the most knowledgeable and experienced sales support in the industry.

Why Choose Metro?



[LEARN MORE](#)

www.metro.com

2022

LO4-029 1/22

Information and specifications are subject to change without notice. Please confirm at time of order.

© 2022 InterMetro Industries Corporation, Wilkes-Barre, PA 18705



We put space to work.

an Ali Group Company



The Spirit of Excellence